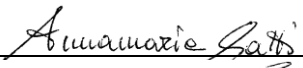
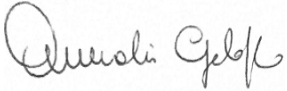
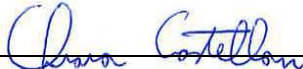
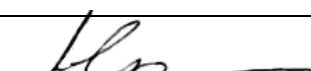

# Sentinel-2 Products Specification Document

<b>Written by</b>	<b>Company</b>	<b>Responsibility</b>	<b>Date</b>	<b>Signature</b>
A. Gatti	ACS		14/03/2018	
A. Galoppo	ACS		14/03/2018	
<b>Verified by</b>				
C. Castellani	ACS	System Engineer	14/03/2018	
<b>Approved by</b>				
F. Carriero	ACS	Project Manager	14/03/2018	

Approval evidence is kept within the documentation management system.

### Documentation Information

Submitted to ESA for

Filename:

Information

Review

Approval

S2-PDGS-TAS-DI-PSD-V14.5.docx

**CHANGE RECORDS**

ISSUE	DATE	§ CHANGE RECORDS	AUTHOR
01	13/01/2012	PDR Issue	ACS Team
02	15/03/2012	Delivery for PDR close-out	ACS Team
		Section 3.21.1: updated file naming convention relative to PDI HKTM as per <b>PDR-RID-26/FM-13</b> disposition.	
		The following sections have been updated as per <b>PDR-RID-70/EC-01</b> disposition: Section 1.6.5: clarified SAFE approach. Sections from 3.5.5 to 3.12: updated PDI's structure. Sections from 4.6 to 4.9: updated User Product structure.	
		The following sections have been updated as per <b>PDR-RID-73/EC-02</b> taking into account comments and discrepancies detected in the <i>rid73 Attachment.pdf</i> document. Section 1.4 Section 1.6.3 Section 1.6.4 Section 1.6.5 Section 2.6 Section 3.7.3.1 Section 3.7.4	
		As per <b>PDR-RID-75/EC-03</b> point 1: Specified in the Table 16, SENSING_TIME field as type date_time: <b>AN_UTC_DATE_TIME</b> . Corrected the corresponding Level-0 Granule schema annexed to this document in the [PSD]_S2-PDGS-TAS-DI-PSD_[02]_Schema.zip file. As per <b>PDR-RID-75/EC-03</b> point 2: Corrected section 4.6.7.3. As per <b>PDR-RID-75/EC-03</b> point 3: Added in the Table 18 and in the corresponding schema GRANULE_DIMENSIONS field.	
		As per <b>PDR-RID-84/EC-04</b> disposition: Clarified in the section 2.10 the metadata management.	
		Section 1.4: clarified schema management as required by <b>PDR-RID-166/JM-04</b> .	
		Sections 3.x.3 (x from 1 to 8) and section 1.4 have been updated as per <b>PDR-RID-217/EC-08</b> request.	
		Sections 1.6.2.1 and 1.6.3: updated according to <b>PDR-RID-239/GV-04</b> disposition.	

ISSUE	DATE	§ CHANGE RECORDS	AUTHOR
		Sections 1.6.2.1, 1.6.3 and 1.6.4: updated as per <b>PDR-RID-240/GV-05</b> disposition.	
		Section 0: updated as per <b>PDR-RID-316/EC-24</b> disposition.	
		Section 4.6.7.1: as required by <b>PDR-RID-464/OC-22</b> this section has been updated providing a preliminary analysis of the product metadata elements to be handled by DAG.	
		Section 4.9.2.1: updated according to ESA response to <b>PDR-RID-465/BK-01</b> .	
		Section 2.8: clarified Level-2A product generation as required by <b>PDR-RID-467/BK-02</b> .	
		Section 1.3: updated <b>clarifying</b> the list of the applicable and reference documents mentioned in this document.	
		Added Section 3.2 to clarify the PDI naming convention.	
		Sections 3.x.3 (x from 1 to 8): for each Granule and Datastrip PDI the content of SAFE Manifest is fully described; an example of Manifest for each PDI is provided in the annexed [PSD]_S2-PDGS-TAS-DI-PSD_[02]_SAFE.zip file.	
		Added Sections 3.23 and 4.9.10 to describe TCI PDI definition and TCI End User Product.	
		Chapter 5: updated Internal Product Format Definition.	
03	06/04/2012	Delivery to include some ESA comments on the previous issue of the document.	ACS Team
		The following sections, figures and tables have been updated according to comments issued by ESA on the previous issue of the PSD delivered for PDR close-out: Section 1.3 Section 1.6.5 Section 3.7.3.1 Section 3.21.1 Section 4.6.7.1 Section 4.6.8 Table 3-6 Table 3-7	

ISSUE	DATE	§ CHANGE RECORDS	AUTHOR
		Figure 16	
		Added section 1.5.1 to give a Sentinel-2 product overview to better understand the purpose of the document.	
		Added sections 3.4 and 3.4.2 to <u>underline</u> the common structure at Granule and Datastrip level.	
		Updated section 3.1 to clarify <i>tar</i> organization and structure.	
		Updated section 3.5.5 regarding to the Level-0 Granule PDI organization and structure.	
04	09/07/2012	Delivery for CDR-4	
		Section 3.21.1: updated naming convention removing File instance ID mandatory prefix "ssss" (Site centre of the file originator) as required by the Panel Disposition of <b>PDR-RID-026/FM-13</b> and <b>S2PP/FM-13/1/PSD</b> (related to <b>S2PP/FM-09/1/P2FICD</b> and <b>PDR-RID-37/FM-09</b> ).	
		Chapter 2: focusing on DIMAP implementation is provided.	
		Chapter 3: updated to complete and better document the PDI format specifications.	
		Chapter 4: updated to complete and better document the User Product format specifications.	
		The sections 4.3 and 4.6.7.1 (Table 82) clarify the processing performed by the DAG-C to compute the QIs at product level.	
		Sections 4.7.9, 4.8.8 and 4.9.9: added the description of <i>manifest</i> files for L1A, L1B and L1C user products.	
		Added Annex C to provide the OLQC_Report.xml report performed by OLQC processor consolidation.	
		Added <i>manifest.safe</i> files and corresponding XSD schemas relative to Level-1A, Level-1B and Level-1C (cfr. [PSD]_S2-PDGS-TAS-DI-PSD_[05]_SAFE.zip annexed to this document).	
05	20/09/2012	This issue of the document includes the following main improvements:  Chapters 1 and 2: updated to help the reader in the understanding of the document;  Section 3.7: included latest feedback from Satellite Ancillary Data;	

ISSUE	DATE	§ CHANGE RECORDS	AUTHOR
		<p>Section 3.20: updated HKTМ PDI defining it as a SAFE Product Data Item;</p> <p>Chapter 4: all metadata for user product level have been provided;</p> <p>All: consolidation of the file naming, including RID S2PP/FM-13/1/PSD (HKTМ file naming now [EOFFS], ref added in applicable documents list);</p> <p>All: CDR-4 Batch 1 RID including ESA red marks taken into account throughout the doc;</p> <p>New version of the XSD schema set according to the document description.</p> <p>Algorithm to generate Product Level QIs as per PDR RID OC-22 agreement (see Table 82)</p>	
06	28/11/2012	Section 1.3: updated applicable and reference documentation according to the new baseline documentation.	
		Section 3.2: Clarified the purpose of the PDI_ID definition as a logical and physical naming convention.	
		<p>Section 3.6.3.1:</p> <ol style="list-style-type: none"> <li>Minor changes on the Table 35: <i>Level-0 Datastrip – Image_Data_Info Description</i> to align the metadata description vs XSD schemas.</li> <li>Updated Table 36: <i>Level-0 Datastrip – Satellite_Ancillary_Data_Info Description</i> according to the new issue of the applicable [PDD] and to align the metadata description vs XSD schemas.</li> <li>Minor changes on the Table 3-32: <i>Level-0 Datastrip – Quality_Indicator_Info Description</i> to add details on metadata description.</li> <li>Updated Table 38 <i>Level-0 Datastrip – Auxiliary_Data_Info Description</i> to add the IERS_BULLETIN_FILENAME reference needed to fill the corresponding product level metadata.</li> </ol>	
		<p>Section 3.8.3.1:</p> <ol style="list-style-type: none"> <li>Added POD_Info (Figure 34 and Table 46) according to the [PDD] description.</li> <li>Updated Table 48 <i>Level-1A Datastrip – Auxiliary_Data_Info Description</i> to add the IERS</li> </ol>	

ISSUE	DATE	§ CHANGE RECORDS	AUTHOR
		Bulletin reference (IERS_BULLETIN_FILENAME) and the Image_Display_Order metadata (RED_CHANNEL, GREEN_CHANNEL, BLUE_CHANNEL).	
		Section 3.10.3.1: 1. Updated Table 55 <i>Level-1B Datastrip – Auxiliary_Data_Info Description</i> to add the IERS Bulletin reference (IERS_BULLETIN_FILENAME), the GRI data reference and the Image_Display_Order metadata.	
		Section 3.11.3.1: 1. Updated Figure 50 and Table 58 according to the applicable [PDD].	
		Section 3.12.3.1: 1. Updated Figure 56 and Table 63: <i>Level-1C Datastrip – Auxiliary_Data_Info Description</i> to include ECMWF_DATA_REF, Image_Display_Order and QUANTIFIATION_VALUE metadata according to [PDD] description.	
		Sections 3.21 and 3.21.1: updated to describe the HKTM PDI as a SAFE product. The corresponding manifest.safe and SAFE schema have been added in the annexed zip file (S2-PDGS-TAS-DI-PSD_[V06]_SAFE.zip).	
		Updated section 4.4.	
		Section 4.6.2.1: 2. Updated ISPs description;	
		Section 4.6.7.1: 1. Minor changes on the Table 79: <i>Level-0 Product_Metadata_File - General_Info Description</i> to add details on metadata description. Added <i>fileFormat</i> attribute for <i>IMAGE_DATA_ID</i> metadata. 2. Minor changes on the Table 80: <i>Level-0 Product_Metadata_File - Geometric_Info Description</i> to add details on metadata description.	

ISSUE	DATE	§ CHANGE RECORDS	AUTHOR
		<p>Section 4.7.7.1:</p> <ol style="list-style-type: none"> <li>Updated Figure 77 and added Table 87: <i>Level-1A Product_Metadata_File - General_Info Description</i> to include the Product_Image_Characteristics according to [PDD] description.</li> </ol>	
		<p>Section 4.8.7.1:</p> <ol style="list-style-type: none"> <li>Updated Figure 85 and added Table 92: <i>Level-1B Product_Metadata_File – Auxiliry_Data_Info Description</i> to include the Restoration_Parameters and Equalization_Parameters according to [PDD] description.</li> </ol>	
		<p>Section 4.9.7.1:</p> <ol style="list-style-type: none"> <li>Removed Radiometric_Info from Product_Metadata_File because, according to [PDD], this group of metadata is available at Datastrip level for each Datastrip composing the product.</li> <li>Added Figure 79 and Table 4-23 to detail the general information provided through the Level-1C_Product_Metadata_File.</li> </ol>	
		Section 5.2.2.2: updated file naming for IPF products.	
		Updated in the whole the document the Processing Baseline definition and management.	
		Updated Annex D to define the OLQC reports naming convention.	
		<b>SYS-1120</b> GML mask format: updated sections 3.4.1, 3.7.2, 3.9.2, 3.11.2. Added annex to describe the grouping strategy to have several masks in one physical GML file.	
		<b>SYS-1121</b> PVI as optional file: updated section 0	
		<b>SYS-1123</b> SAFE format approach packaging: updated section 4.2.	
		<b>SYS-1124</b> Level-0 Granule Physical Format: updated section 3.5.7 and clarified in all the document that L0 Granules come with one image file per band and per detector.	
		<b>SYS-1125</b> Level-0 User Product Data Organization: updated section 4.6.2.1.	
		<b>SYS-1127</b> General Comment on the physical	

ISSUE	DATE	§ CHANGE RECORDS	AUTHOR
		presentation: updated section 4 to include within the User Product physical format an UserProduct_index.html file.	
		<b>SYS-1129</b> Readability of the Document: checked all cross-references and links to tables, figures and sections.	
		<b>SYS-1130</b> SAD raw Data: updated section 4.6.3, Table 10 and Table 11.	
07	22/02/2013	CDR Delivery	
		Added [OLQC-TN] reference document.	
		Removed [CCTC-IPF] reference document because not available for the end user.	
		The obsolete section Document Roadmap has been replaced with the section “How to Use this Document” to help the reader in navigating in the document.	
		Section 0: added AS-4 regarding raw SAD data organization.	
		Section 3: all PDI naming conventions and PDI_ID definitions have been updated according to [EOFFS-PDGS].	
		Section 3.5.8.2: updated IMG_DATA description.	
		Section 3.22 and 3.22.1: updated to describe the SAD files management as per AS-4.	
		Added at Datastrip level (Table 3-32) the following metadata: DATATAKE_SENSING_STOP DATASTRIP_SENSING_START DATASTRIP_SENSING_STOP Renamed SENSING_TIME metadata as DATATAKE_SENSING_START	
		As per RID/ESA-217, removed the <b>metadata</b> : - Corrected_Attitudes/Values/VELOCITY_VALUES - Corrected_Attitudes/Values/VELOCITY_ERRORS from the document (Table 36) and the corresponding XSD schema.	
		Removed DEGRADED_ANC_DATA_PERCENTAGE metadata from Granule level (Table 18, Table 30, Table 42, Table 52, Table 59). This information is available at Datastrip level through the	



ISSUE	DATE	§ CHANGE RECORDS	AUTHOR
		“degradationPercentage” attribute.	
		Section 4: updated User Product structure to include the HTML folder containing a product presentation file ( <b>SYS-1127</b> ).	
		Section 4.6.2.1: updated L0 Data Organization description.	
		Section 4.6.3: updated Ancillary Data description.	
		Removed all reference to DEM Quality Masks because no quality mask is available.	
		Removed section 5. INTERNAL PRODUCT FORMAT DEFINITION because not End User oriented. All information has been moved in the appropriate ICDs.	
		Added table in the Annex B to clarify the meaning and the applicability of each inventory metadata.	
		All: the document has been updated to clarify that there are not redundant metadata in the SAFE formatted User Product.	
		<p>Modifies on XSD schemas:</p> <p>dimap.xsd:</p> <ol style="list-style-type: none"> <li>removed VELOCITY_VALUES and VELOCITY_ERRORS metadata from AN_ATTITUDE_DATA_INV complexType;</li> <li>removed “bandId” attribute from A_GRANULE_FOOTPRINT complexType</li> </ol> <p>item.xsd:</p> <ol style="list-style-type: none"> <li>updated all the regular expression according to the new PDI-ID naming conventions</li> </ol> <p>Inventory_Metadata.xsd:</p> <ol style="list-style-type: none"> <li>updated all the regular expression according to the new PDI-ID naming conventions</li> <li>added <b>attestations</b> to clarify the applicability for each metadata</li> </ol> <p>Added the following schemas to validate the XML metadata files in case of User Product SAFE formatted:</p> <p>SAFE_user_product_Level-0.xsd SAFE_user_product_Level-1A.xsd SAFE_user_product_Level-1B.xsd</p>	

ISSUE	DATE	§ CHANGE RECORDS	AUTHOR
		SAFE_user_product_Level-1C.xsd	
08	17/05/2013	Delivery for CDR Close-out Batch1	
		<b>ESA-681 Metadata in case of AT granule aggregation:</b> updated section 4.7.8 to include <ul style="list-style-type: none"> <li>• Details about Along-Track Granules Aggregation;</li> <li>• Aggregated Granule ID definition;</li> <li>• Aggregated Granule Physical Format description;</li> <li>• Aggregated Granule Metadata definition.</li> </ul>	
		<b>ESA-688 GML mask generation strategy:</b> updated sections 3.7.2, 3.8.2 and 3.9.2 to clarify that the mask files are divided per band. The mask naming convention and the masks grouping strategy described in the Annex E of the document have been updated accordingly.	
		<b>ESA-752: tile conso approach vs PSD:</b> updated section 4.9.8 to include the following information: <ul style="list-style-type: none"> <li>• Description of the Tile Consolidation concept;</li> <li>• Tile consolidated ID definition;</li> <li>• Tile consolidated metadata definition.</li> </ul>	
		<b>ESA-770: Point and comments on the [PSD]:</b> the whole document has been updated to implement the comments listed in the RID PRO-19.pdf annexed to this issue.	
		<b>ESA-836 Download Options:</b> updated section 4.4 and Table 79 to align the download options The User Product XSD schemas have been updated accordingly.	
		<b>ESA-571 Sentinel-SAFE Manifest and Product Organization:</b> updated all "SAFE Manifest synoptic table" sections and the example of the SAFE Manifest provided in the zip annexed to the document.	
		<b>ESA-826 Points on [PSD]:</b> The whole document has been updated to implement the comments listed in the RID PRO-2.pdf annexed to this issue.	
		Updated section 3.6.3.1 - Table 36 to have the same Satellite_Ancillary_Data_Info for each level of processing.	
		<b>ESA-751 GID definition / Versioning :</b> updated section 4.2 removing the version id (_Cvvvv).	

ISSUE	DATE	§ CHANGE RECORDS	AUTHOR
		Added [OLQC-GIPP] reference document.	
		Annex B: updated Inventory_Metadata description	
		Annex D: updated OLQC report (XSD and XML)	
		A new directory "AUX_DATA" folder containing ECMWF dataset resampled in UTM projection has been added for L1c PDI (note that this modification will request an update of the ICD-IPF V11).	
09	14/06/2013	<b>ESA-751</b> <i>GID definition / Versioning</i> : updated section 0 and 0 to add the Processing Baseline in the Datatake_ID (and Group_ID) definition.	
		<b>ESA-795</b> <i>No PDI definition for compression by-passed</i> : updated Table 35 to change the metadataLevel on ACTIVE_DETECTOR from <i>Expertise</i> to <i>Brief</i> ; updated Figure 59 and Table 79 to add the ON_BOARD_COMPRESSION_MODE metadata; updated sections 3.5.8.2 and 4.6.1 to include the compression by-passed description.	
		Section 1.3: added [GRIB] reference document.	
		Section 0: updated to clarify which auxiliary data can be embedded in the User Product.	
		Section 0: updated to include ESA's comments on PSD V08 delivered for CDR Close-Out Batch1.	
		Section 3.8.3.1: updated Table 3-43 and Table 3-46 to move Image_Display_Order node from Auxiliary_Data_Info to Image_Data_Info.	
		Section 3.10.3.1: updated Table 3-51 and Table 3-53 to move Image_Display_Order node from Auxiliary_Data_Info to Image_Data_Info.	
		Section 3.12.3.1: updated Table 3-59 and Table 3-61 to move Image_Display_Order node and QUANTIFICATION_VALUE metadata from Auxiliary_Data_Info to Image_Data_Info.	
		Section 3.11.3.1: updated Table 3-56 to add <b>detailed</b> regarding EPSG codes.	
		Section 3.20: added details on ECMWF PDI.	
		Updated the following sections to align the User Product Quality <b>Indicators to OLQC</b> procedures, checks and checklist names consolidation: sections 4.3, 4.6.5, 4.6.7.1, 4.7.7.1, 4.8.7.1 and 4.9.7.1	
		Updated the following sections to add the <i>Processing_Specific_Parameters</i> field (optional field	

ISSUE	DATE	§ CHANGE RECORDS	AUTHOR
		reserved for production chain only but not propagated to User Product): sections 3.4.1, 3.5.1, 3.5.8.1, 3.6.3.1, 3.7.3.1, 3.8.3.1, 3.9.3.1 and 3.11.3.1.	
		The section 4 has been updated to clarify the content of the GRANULE and DATASTRIP folders inside the User Product.	
		Removed all reference to Cloud Mask for Level-0 Datastrip PDI (see comments in RID ESA-770).	
		Renamed in the Table 35 the metadata NUMBER_OF_T00_DEGRADED_PACKETS as NUMBER_OF_TOO_DEGRADED_PACKETS	
		Annex C: updated figure and example in the <i>OLQC Report</i> as per OLQC checks and checklist name consolidation.	
		Annex F: updated mask files description.	
		All: renamed the PDI XSD schema.	
		All: updated to include ESA's comments on PSD V08 delivered for CDR Close-Out Batch1.	
10	12/07/2013	<b>ESA-795</b> <i>No PDI definition for compression by-passed</i> : updated sections 0 and 3.5.8.2.	
		Sections 3.11.2, 3.20: <b>removed</b> . <b>grib</b> extension for ECMWF data.	
		Sections 3.2, 3.16.1, 3.17.1, 3.18.1, 3.20.1: added "S2_" Mission ID applicable to the constellation and used by satellite independent files.	
		Section 3.2, Annex <b>E</b> : removed <i>General Parameters File</i> being an obsolete GIPP file.	
		Sections 3.15.1, 3.16.1, 3.17.1: updated to set "MPC_" as unique site centre originator of GIPP/DEM/GRI data.	
		Section 3.22: updated to add DPC annotation to SAD packets.	
		Section 0: updated PVI format.	
		Section 3.20.1: updated ECMWF centre originator.	
		Section 4.6.2.1: updated DPC annotations.	
		Annex C: clarified that the <i>Inventory_Metadata.xml</i> file is only for internal usage.	
		Annex G: updated example of metadata file for a Granule Aggregation	

ISSUE	DATE	§ CHANGE RECORDS	AUTHOR
11	28/03/2014	Sections 3.4.1, 3.5.8.1, 3.7.3.1, 3.9.3.1, 4.7.8.3: updated SENSING_TIME metadata definition.	
		Section 3.18 and Table 13: updated POD file type and naming convention according to the applicable [POD-FFS].	
		Section 3.2, Table 6: added new GIP_CONVERT file type. This new GIPP file is used for L1C processing.	
		Section 4.9.1: GS-CDR RID implementation ( <b>SYS-2179</b> missing QUANTIFICATION VALUE formula).	
		Section 2.14 and entire section 4: replaced "Preview Image" with "Browse Image" in User Product context. Updated Browse Image in PNG format.	
		Section 4.2: added clarifications regarding AUX_DATA content and Browse Image definition. Changed the Browse Image file type to reflect the new name used for the Browse Images in User Product context.	
		Section 3.11.2: clarified PVI naming convention and corrected typo in the Figure 48.	
		Section 3.15: updated GIPP PDI packaging definition.	
		Section 3.6.3.1, Table 36: updated QUATERNION_VALUES convention as (qv1 qv2 qv3 qs).	
		Section 3.5.8.2: updated ISP annotations description.	
		Section 3.1: updated note about TAR packaging.	
		Section 3.20.1: removed incorrect reference to [EOFFS-PDGS].	
		Section 3.22: updated to remove <i>Inventory_Metadata.xml</i> file from SAD PDI.	
		Sections 3.5.8.1, 3.7.3.1 and 3.9.3.1: added QL_FOOTPRINT metadata in Granule <i>Geometric_Info</i> node.	
		Removed from the document the Annex C containing the <i>Inventory_Metadata.xml</i> definition. This file is not relevant to the User Product definition and it shall be described in the relevant internal ICDs.	
		Removed from the document the tables containing the obsolete assumptions and open points.	
		The Chapters 1 & 2 and the appendices of the document have been reorganized and streamlined to	

ISSUE	DATE	§ CHANGE RECORDS	AUTHOR
		<p>have a document more End User oriented.</p> <p>Main changes:</p> <ul style="list-style-type: none"> <li>- Removed Annex C (Inventory_Metadata) and Annex I (Logical Product)</li> <li>- Added list of Acronyms used in document</li> <li>- Added the section "Sentinel-2 Mission Overview" to merge some relevant high-level summary info &amp; diagrams on the Mission and MSI description</li> <li>- Reshuffled the subsections of the Chapter 2</li> </ul>	
		<p>Sections 3.6.3.1, 3.8.3.1 and 4.6.7.1: removed DATATAKE_SENSING_STOP metadata because redundant with DATASTRIP_SENSING_STOP at Datastrip level and misleading at User Product Level.</p>	
		<p>Section 4.6.7.1: added PRODUCT_START_TIME and PRODUCT_STOP_TIME metadata to have at metadata level the actual start/stop time of the product.</p>	
		<p>Section 4.2: clarified the meaning of the "Start time" and "Stop time" used in the User Product naming convention.</p>	
		<p>Sections 4.4 and 4.6.7.1: added the query option "Area_Of_Interest".</p>	
		<p>Section 3.6: updated the whole section to clarify that in QI_DATA folder there are five ( 5 ) Quicklook files in JP2 format.</p>	
		<p>Sections 3.6.3.1: updated to define the REF_QL_IMAGE metadata as the pointer to the folder (QI_DATA) containing the preliminary Quicklook files.</p>	
		<p>Sections 3.6 and 4: updated to clarify that the SAD raw data included in the L0 User Product shall taken from the last Datastrip selected to be included in the product.</p>	
		<p>Updated the document to :</p> <ul style="list-style-type: none"> <li>- further clarify the difference between SAD PDI &amp; SAD files inside the L0 Datastrip PDI.</li> <li>- define the ANC_DATA_REF metadata as the pointer to the folder (inside the L0 Datastrip PDI) containing the SAD raw data files.</li> </ul>	
		<p>Section 3.8.3.1: corrected typo in Figure 35 and Table 3-45 to align the document to the actual XSD</p>	

ISSUE	DATE	§ CHANGE RECORDS	AUTHOR
		schema.	
		Section 3.10.3.1: corrected typo in Figure 45 and Table 3-52 to align the document to the actual XSD schema.	
		Section 3.12.3.1: corrected typo in Figure 55 and Table 3-60 to align the document to the actual XSD schema.	
12	10/09/2014	Section 1.3 updated according to the applicable technical baseline documentation.	
		Sections 3.12.3.1 and 4.9.7.1: updated to add Reflectance Conversion information. The <i>metadataLevel</i> attribute has been defined as "Standard" according to the PSD-XSD.	
		Section 3.6.3.1 and Figure 20: updated General_Info/Processing_Info definition.	
		Section 3.8.3.1 and Figure 32: updated General_Info/Processing_Info definition.	
		Section 3.6.3.1: updated the <i>metadataLevel</i> attribute (Expertise) related to the ACTIVE_DETECTOR metadata.	
		<p>Section 3.6.3.1:</p> <p>Removed the fields:</p> <ul style="list-style-type: none"> <li>Satellite_Ancillary_Data_Info/Attitudes/Corrected_Attitudes/Values/QUATERNION_STATUS</li> <li>Satellite_Ancillary_Data_Info/Attitudes/Raw_Attitudes/STR_List/STR/Attitude_Data_List/Attitude_Data/QUATERNION_STATUS</li> </ul> <p>Renamed the field:</p> <ul style="list-style-type: none"> <li>Satellite_Ancillary_Data_Info/Attitudes/Raw_Attitudes/STR_List/STR/Attitude_Data_List/Attitude_Data/ATTITUDE_QUALITY_INDICATOR</li> </ul> <p>as:</p> <ul style="list-style-type: none"> <li>Satellite_Ancillary_Data_Info/Attitudes/Raw_Attitudes/STR_List/STR/Attitude_Data_List/Attitude_Data/ATTITUDE_QUALITY</li> </ul> <p>Added the field:</p> <ul style="list-style-type: none"> <li>Satellite_Ancillary_Data_Info/Attitudes/Corrected_Attitudes/Values/ATTITUDE_QUALITY_INDICATOR</li> </ul>	
		Section 3.6.3.1: added OPTIONAL node:	

ISSUE	DATE	§ CHANGE RECORDS	AUTHOR
		<ul style="list-style-type: none"> <li>Satellite_Ancillary_Data_Info/Other_Ancillary_Data /CSM_Flags_List/Values/INUSE_FLAG</li> </ul>	
		All: updated the document according to the CGS and PAC ID defined in [ EOFFS-PDGS]	
		Section 1.3: Added the reference to [EOM-OGC] and [S2MSK-TN] documents.	
		Section 3.5.7 and Annex C: corrected typo error to align the L0 Granule checklist name to the Table 3-17.	
		Sections 3.5.1 and 4.6.7.3: clarified the meaning of the ANC_DATA_REF metadata inside a L0 Datastrip PDI and a L0 User Product.	
		Section 3.6.2: added the default values for the 5 limited band in the Datastrip QI_DATA folder.	
		Sections 4.1, 4.6.3 and 4.6.7.5: clarified the time coverage of the SAD data embedded inside the L0 User Product.	
		Section 3.2 : Updated Table 3-8 and Table 3-9.	
		Sections 3.6.2 and 3.22.1: clarified the extension “.bin“ for the SAD files.	
		Section 3.5.8.1: clarified the EXT_POS_LIST definition.	
		Removed the obsolete reference document [GRI-TN] and added the applicable [GRI-FFS].	
		Section 3.17: modified section according to [GRI-FFS].	
		Section 3.17.1: modified section according to [GRI-FFS].	
13	12/10/2015	Section 4.9.7.1: Implemented the issue ESA-3174. Renamed the metadata ECMWF_FILENAME as ECMWF_DATA_REF	
		Updated Figure 56 and Table 63 to implement the issue ESA-3630	
		Updated Figure 48 to implement the issue ESA-3175	
		Updated Annex D to implement the issue ESA-3334	
		Updated Annex C to implement the issue ESA-4084	
		Removed [OLQC-TN] as applicable document and updated the Annex C to implement the issue ESA-3254.	



ISSUE	DATE	§ CHANGE RECORDS	AUTHOR
		Replaced the file type GIP_R2EQOB with file type GIP_R2EOB2 according to the issue OPS-469	
13.1	19/11/2015	This issue of the document does not contain any change respect to the previous one in version 13.0. The version number has been updated only to <b>maintain</b> the alignment versus the PSD-XSD annexed to this document issued with version number 13.1.	
13.2	04/05/2016	Updated section 4.9.1, section 4.9.8 and Table 3-57 according to the issue [ESA-4232]	
14.0	15/07/2016	Updated section 4.4: with new download options by addition of: <ul style="list-style-type: none"> <li>• <i>Compact Naming Convention</i> option (SAFE_COMPACT)</li> <li>• <i>Single Tile Product Packaging</i></li> <li>• <i>Complete Single Tile</i></li> <li>• <i>Spectral Band</i> updated to include option of TCI images “as a band”</li> </ul>	
		Added section 4.2.1 to define the <i>Products Compact Naming</i> convention root directory for all product levels	
		Added section 4.9.10 to define the Level-1C <i>Product Compact Naming</i> convention for the other product components beyond the root directory	
		Added section 4.9.11 to define the Level-1C Single Tile User Product format which includes definition of the option for Complete tile	
		Added section 4.9.12, in replacement of former section 4.10 removed from this version of the document, to define the filename convention of the TCI “as a band”	
		Updated section 4.6.7 Table 79 defining the <i>General_Info</i> product metadata section driven by new download options defined in section 4.4; this metadata item defined in such section is common to all product levels.	
		Section 3.18 regarding POD PDI has been deleted (not applicable to the Sentinel-2 products definition).	
		New set of schemas attached which are aligned to the version of the document: <ul style="list-style-type: none"> <li>• S2-PDGS-TAS-DI-PSD-V14_Schemas.zip</li> <li>• S2-PDGS-TAS-DI-PSD-V14_SAFE.zip</li> </ul>	

ISSUE	DATE	§ CHANGE RECORDS	AUTHOR
14.1	30/09/2016	Update section 4.4 and 4.9.11.2 for Complete Single Tile aux data and BWI removed.  Update section 4.6.7.1: Add new possible value in case of ngEO not available for the <b>fields</b> : PREVIEW_IMAGE_URL and PREVIEW_GEO_INFO.	
14.2	24/10/2016	PSD : <ul style="list-style-type: none"> <li>• Updated Table 4-9 for new management of Complete Single Tile inside Query_options tag.</li> <li>• All references to the land/water mask have been removed</li> <li>• Typos corrected</li> </ul> Schemas : <ul style="list-style-type: none"> <li>• Updated DICO/14/PDGS/dimap/dimap.xsd</li> </ul>	
14.3	27/09/2017	PSD : <ul style="list-style-type: none"> <li>• Update of the Annex D (GIPPs) for removal of unused GIP_R2MACO and GIP_R2DEBA and correction of the appearance levels for other GIPPs</li> <li>• Update of the L1B and L1C PDI and EUP Auxiliary_Data_Info_Diagram schemas to indicate the new GRI_List node (sections 3.11.3, 3.13.3, 4.8.7.1, 4.9.7.1)</li> <li>• Updated section 4.9.11.2; Product discriminator definition for the “complete single tile” products has been updated.</li> <li>• Removed section 4.9.11.3</li> <li>• Changed Figure 64, Figure 70 and Table 4-12 according to new quality_inspections section</li> <li>• Updated table in 2.4 paragraph (MSI bands).</li> <li>• Changed Figure 46 and Figure 56.</li> <li>• In Table 4-12 updated description of the field quality_check/@check_type</li> <li>• Removed FLAG suffix from quality indicators checktype (Table 4-12, section 4.8.7.1, section 4.9.7.1)</li> <li>• Updated 4.3 paragraph, table 4-12 and 4.7.8.2 paragraph to include all OLQC report in the EUP.</li> </ul> Schemas : <ul style="list-style-type: none"> <li>• Updated DICO subdirectories names to PDI-V14 and EUP-V14 and associated links in XSDs</li> <li>• Addition of the previously removed node</li> </ul>	

ISSUE	DATE	§ CHANGE RECORDS	AUTHOR
		Image_Refining after PSD V13 for PDI validation <ul style="list-style-type: none"> <li>• Addition of the GRI_List node for L1B / L1C PDIs and EUPs as per IPFSPR-437 and IPFSPR-501</li> <li>• ECMWF node now optionnal as per IPFSPR-383</li> <li>• Modification of the Quality_Control_Checks as per US-526</li> <li>• Removal of all references to GIP_R2DEBA and GIP_R2MACO</li> </ul>	
14.4	01/03/2018	New sections for Level-2A PDI and L2A user product added : <ul style="list-style-type: none"> <li>• Level-2A Tile PDI definition section added</li> <li>• Level-2A Datastrip PDI definition section added</li> <li>• Level-2A User Product Specification section added</li> </ul> Schemas : <ul style="list-style-type: none"> <li>• New schemas added for Level-2A PDI structure and metadata</li> <li>• New schemas added fro Level-2A User Product structure and metadata</li> <li>• New schemas added for Level-2A User Product manifest file</li> </ul>	
14.5	14/03/2018	Removed references to [GPP-DEM] obsolete after integration of L2A Schemas: <ul style="list-style-type: none"> <li>• Added validation pattern to allow double DS identifier in L2A tile metadata for consolidated data.</li> <li>• Modification of manifest schema to anticipate improvement of SAFE manifest</li> </ul>	

## TABLE OF CONTENTS

<b>1. INTRODUCTION .....</b>	<b>30</b>
1.1 PURPOSE OF THE DOCUMENT .....	30
1.2 DOCUMENT ORGANISATION AND MAIN INDEX .....	30
1.3 REFERENCE DOCUMENTS .....	32
1.4 ACRONYMS .....	34
1.5 SENTINEL-2 MISSION OVERVIEW .....	36
1.6 SENTINEL-2 PRODUCT OVERVIEW.....	39
1.6.1 User Product General Description.....	39
1.6.2 User Product Format.....	40
1.6.3 Complete Single Tile Products (Level-1C and Level-2A).....	41
<b>2. SENTINEL-2 PRODUCT DEFINITIONS.....</b>	<b>42</b>
2.1 ORBIT .....	42
2.2 DATATAKE .....	42
2.3 DATASTRIP .....	43
2.4 MSI BANDS .....	44
2.5 MSI DETECTORS .....	45
2.6 MSI SCENE.....	45
2.7 PRODUCT GRANULES .....	46
2.7.1 Granules .....	46
2.7.2 Tiles and UTM Tiled Grid .....	47
2.7.3 Granules Along-Track Aggregation .....	48
2.7.4 Tile Consolidation .....	48
2.8 PRODUCT LEVELS .....	49
2.9 PROCESSING BASELINE.....	51
2.10 METADATA .....	51
2.11 QUALITY INDICATOR (QI) DATA .....	52
2.12 SATELLITE ANCILLARY DATA .....	52
2.13 AUXILIARY DATA .....	52
2.14 BROWSE IMAGE DATA .....	53
<b>3. PDI FORMAT DEFINITION.....</b>	<b>54</b>
3.1 TYPE OF PDI .....	54
3.2 PDI NAMING CONVENTION .....	56
3.3 PDI HIERARCHY .....	62
3.4 GRANULE/TILE PDI COMMON STRUCTURE.....	63
3.4.1 Granule_Metadata_File Structure .....	64
3.4.2 Granule/Tile PDI_ID Definition.....	74
3.4.3 Granule/Tile PDI XSD Schemas.....	76
3.4.4 Granule/Tile PDI SAFE Format Approach.....	77
3.5 DATASTRIP PDI COMMON STRUCTURE .....	79
3.5.1 Datastrip_Metadata_File Structure .....	80
3.5.2 Datastrip PDI_ID Definition .....	87
3.5.3 Datastrip PDI XSD Schemas .....	88
3.5.4 Datastrip PDI SAFE Format Approach .....	89

3.5.5	<i>Level-0 Granule PDI definition</i> .....	90
3.5.6	<i>PDI_ID definition</i> .....	91
3.5.7	<i>Level-0 Granule Physical Format</i> .....	92
3.5.8	<i>Level-0 Granule PDI Structure</i> .....	94
3.5.9	<i>SAFE Manifest synoptic table</i> .....	105
3.6	LEVEL-0 DATASTRIP PDI DEFINITION .....	116
3.6.1	<i>PDI_ID definition</i> .....	116
3.6.2	<i>Level-0 Datastrip Physical Format</i> .....	117
3.6.3	<i>Level-0 Datastrip PDI Structure</i> .....	119
3.6.4	<i>SAFE Manifest synoptic table</i> .....	145
3.7	LEVEL-1A GRANULE PDI DEFINITION .....	152
3.7.1	<i>PDI_ID definition</i> .....	152
3.7.2	<i>Level-1A Granule Physical Format</i> .....	153
3.7.3	<i>Level-1A Granule PDI Structure</i> .....	156
3.7.4	<i>SAFE Manifest synoptic table</i> .....	167
3.8	LEVEL-1A DATASTRIP PDI DEFINITION .....	174
3.8.1	<i>PDI_ID definition</i> .....	174
3.8.2	<i>Level-1A Datastrip Physical Format</i> .....	175
3.8.3	<i>Level-1A Datastrip PDI Structure</i> .....	177
3.8.4	<i>SAFE Manifest synoptic table</i> .....	194
3.9	LEVEL-1B GRANULE PDI DEFINITION .....	202
3.9.1	<i>PDI_ID definition</i> .....	202
3.9.2	<i>Level-1B Granule Physical Format</i> .....	203
3.9.3	<i>Level-1B Granule PDI Structure</i> .....	206
3.9.4	<i>SAFE Manifest synoptic table</i> .....	216
3.10	LEVEL-1B DATASTRIP PDI DEFINITION.....	217
3.10.1	<i>PDI_ID definition</i> .....	217
3.10.2	<i>Level-1B Datastrip Physical Format</i> .....	218
3.10.3	<i>Level-1B Datastrip PDI Structure</i> .....	220
3.10.4	<i>SAFE Manifest synoptic table</i> .....	233
3.11	LEVEL-1C TILE PDI DEFINITION.....	241
3.11.1	<i>PDI_ID definition</i> .....	241
3.11.2	<i>Level-1C Tile Physical Format</i> .....	242
3.11.3	<i>Level-1C Tile PDI Structure</i> .....	245
3.11.4	<i>SAFE Manifest synoptic table</i> .....	255
3.12	LEVEL-1C DATASTRIP PDI DEFINITION.....	263
3.12.1	<i>PDI_ID definition</i> .....	263
3.12.2	<i>Level-1C Datastrip Physical Format</i> .....	264
3.12.3	<i>Level-1C Datastrip PDI Structure</i> .....	265
3.12.4	<i>SAFE Manifest synoptic table</i> .....	276
3.13	LEVEL-2A TILE PDI DEFINITION .....	284
3.13.1	<i>PDI_ID definition</i> .....	284
3.13.2	<i>Level-2A Tile PDI Structure</i> .....	286
3.14	LEVEL-2A DATASTRIP PDI DEFINITION .....	298
3.14.1	<i>PDI_ID definition</i> .....	299
3.14.2	<i>Level-2A Datastrip Physical Format</i> .....	300
3.14.3	<i>Level-2A Datastrip PDI Structure</i> .....	300
3.15	PDI FOR GIPP FILES DEFINITION .....	302
3.15.1	<i>PDI-ID definition</i> .....	302

3.16	PDI FOR DEM FILE DEFINITION .....	303
3.16.1	PDI-ID definition .....	304
3.17	PDI FOR GRI DEFINITION .....	304
3.17.1	PDI-ID definition .....	305
3.18	PDI FOR IERS BULLETIN FILE DEFINITION .....	306
3.18.1	PDI-ID definition .....	306
3.19	PDI FOR POD FILE DEFINITION (DELETED) .....	306
3.20	PDI FOR ECMWF DATA DEFINITION .....	306
3.20.1	PDI-ID definition .....	307
3.21	S2 HKTM PDI DEFINITION .....	308
3.21.1	PDI-ID definition .....	308
3.22	SAD PDI DEFINITION .....	309
3.22.1	PDI-ID definition .....	310
3.23	TCI PDI DEFINITION .....	312
3.23.1	PDI-ID definition .....	312

**4. USER PRODUCT PHYSICAL FORMAT DEFINITION..... 313**

4.1	S2 USER PRODUCT PHYSICAL FORMAT .....	313
4.1.1	User Product XSD Schemas .....	317
4.2	S2 USER PRODUCT NAMING CONVENTION .....	317
4.2.1	Compact Naming Convention .....	321
4.3	USER PRODUCT QUALITY INDICATORS .....	322
4.4	DOWNLOAD OPTIONS .....	322
4.5	USER PRODUCT SAFE FORMAT APPROACH .....	324
4.6	LEVEL-0 USER PRODUCT SPECIFICATION .....	326
4.6.1	Introduction .....	326
4.6.2	Image Data .....	328
4.6.3	Ancillary Data .....	330
4.6.4	Auxiliary Data .....	331
4.6.5	Quality Indicators .....	331
4.6.6	Metadata .....	332
4.6.7	User Product Level-0 Structure .....	333
4.6.8	User Product Level-0 SAFE Manifest synoptic table .....	356
4.7	LEVEL-1A USER PRODUCT SPECIFICATION .....	365
4.7.1	Introduction .....	365
4.7.2	Image Data .....	367
4.7.3	Ancillary Data .....	368
4.7.4	Auxiliary Data .....	369
4.7.5	Quality Indicators .....	369
4.7.6	Metadata .....	370
4.7.7	User Product Level-1A Structure .....	371
4.7.8	Level-1A Granules Aggregation .....	382
4.7.9	User Product Level-1A SAFE Manifest synoptic table .....	387
4.8	LEVEL-1B USER PRODUCT SPECIFICATION .....	394
4.8.1	Introduction .....	394
4.8.2	Image Data .....	395
4.8.3	Ancillary Data .....	396
4.8.4	Auxiliary Data .....	396
4.8.5	Quality Indicators .....	396

4.8.6	<i>Metadata</i> .....	398
4.8.7	<i>User Product Level-1B Structure</i> .....	399
4.8.8	<i>User Product Level-1B SAFE Manifest synoptic table</i> .....	409
4.9	<b>LEVEL-1C USER PRODUCT SPECIFICATION</b> .....	410
4.9.1	<i>Introduction</i> .....	410
4.9.2	<i>Image Data</i> .....	411
4.9.3	<i>Ancillary Data</i> .....	413
4.9.4	<i>Auxiliary Data</i> .....	413
4.9.5	<i>Quality Indicators</i> .....	415
4.9.6	<i>Metadata</i> .....	416
4.9.7	<i>User Product Level-1C Structure</i> .....	417
4.9.8	<i>Tiles Consolidation</i> .....	427
4.9.9	<i>User Product Level-1C SAFE Manifest synoptic table</i> .....	431
4.9.10	<i>Compact Naming Convention for LIC</i> .....	438
4.9.11	<i>Single Tile User Product</i> .....	450
4.9.12	<i>True Colour Image Naming Convention</i> .....	454
4.10	<b>LEVEL-2A USER PRODUCT SPECIFICATION</b> .....	454
4.10.1	<i>Introduction</i> .....	454
4.10.2	<i>Image Data</i> .....	457
4.10.3	<i>Ancillary data</i> .....	458
4.10.4	<i>Auxiliary Data</i> .....	458
4.10.5	<i>Quality Indicators</i> .....	459
4.10.6	<i>Metadata</i> .....	460
4.10.7	<i>User product Level-2A Structure</i> .....	460
4.10.8	<i>Tiles Consolidation</i> .....	468
4.10.9	<i>Single Tile User Product</i> .....	468
<b>ANNEX A: USER PRODUCT BASED ON DIMAP FORMAT</b> .....		<b>470</b>
<b>ANNEX B: INSPIRE METADATA</b> .....		<b>471</b>
<b>ANNEX C: OLQC REPORT XSD</b> .....		<b>492</b>
<b>ANNEX D: GROUND IMAGE PROCESSING PARAMETERS (GIPP)</b> .....		<b>495</b>
<b>ANNEX E: MASK TYPES AND GROUPING STRATEGY FOR L1 PRODUCTS</b> .....		<b>500</b>
<b>ANNEX F: EXAMPLE OF METADATA FILE FOR A GRANULE AGGREGATED</b> .....		<b>505</b>
<b>ANNEX G: JPEG2000 COMPRESSION</b> .....		<b>509</b>

### Table of Figures

FIGURE 1: MSI SPECTRAL-BANDS VERSUS SPATIAL RESOLUTION .....	36
FIGURE 2: STAGGERED DETECTOR CONFIGURATION AND INTER-DETECTOR/INTER-BAND PARALLAX ANGLES .....	37
FIGURE 3: LIC USER PRODUCT AGGREGATING ALL TILES INTERSECTING A USER DEFINED AREA-OF-INTEREST .....	39
FIGURE 4: DATATAKE SEGMENTATION IN DATASTRIPS .....	43
FIGURE 5: EXAMPLE OF GRANULES COVERING AN AREA-OF-INTEREST OF THE USER .....	46
FIGURE 6: EXAMPLE OF TILING (100x100km <sup>2</sup> ) WITHIN THE UTM15 ZONE .....	47
FIGURE 7: GRANULES AGGREGATED ALONG-TRACK .....	48
FIGURE 8: TILE PAIRS CONSOLIDATION .....	49
FIGURE 9: GRANULE / TILE COMMON STRUCTURE .....	63
FIGURE 10: GRANULE_METADATA_FILE .....	64
FIGURE 11: DATASTRIP COMMON STRUCTURE .....	79
FIGURE 12: DATASTRIP_METADATA_FILE .....	80
FIGURE 13: PDI LEVEL-0 GRANULE STRUCTURE .....	90
FIGURE 14: PDI LEVEL-0 GRANULE PHYSICAL FORMAT .....	93
FIGURE 15 : LEVEL-0_GRANULE_METADATA_FILE - GENERAL_INFO DIAGRAM .....	96
FIGURE 16: LEVEL-0_GRANULE_METADATA_FILE - GEOMETRIC_INFO DIAGRAM .....	98
FIGURE 17: LEVEL-0_GRANULE_METADATA_FILE - QUALITY_INDICATORS_INFO DIAGRAM .....	101
FIGURE 18: PDI LEVEL-0 DATASTRIP STRUCTURE .....	116
FIGURE 19: PDI LEVEL-0 DATASTRIP PHYSICAL FORMAT .....	118
FIGURE 20: LEVEL-0 DATASTRIP - GENERAL_INFO DIAGRAM .....	121
FIGURE 21 : LEVEL-0 DATASTRIP – IMAGE_DATA_INFO DIAGRAM .....	125
FIGURE 22: LEVEL-0 DATASTRIP – SATELLITE Ancillary_DATA_INFO DIAGRAM .....	129
FIGURE 23 : LEVEL-0 DATASTRIP – QUALITY_INDICATORS_INFO DIAGRAM .....	138
FIGURE 24 : LEVEL-0 DATASTRIP – AUXILIARY_DATA_INFO DIAGRAM .....	141
FIGURE 25: PDI LEVEL-1A GRANULE STRUCTURE .....	152
FIGURE 26: PDI LEVEL-1A GRANULE PHYSICAL FORMAT .....	155
FIGURE 27: LEVEL-1A_GRANULE_METADATA_FILE - GENERAL_INFO DIAGRAM .....	159
FIGURE 28: LEVEL-1A_GRANULE_METADATA_FILE - GEOMETRIC_INFO DIAGRAM .....	161
FIGURE 29: LEVEL-1A_GRANULE_METADATA_FILE – QUALITY_INDICATORS_INFO DIAGRAM .....	164
FIGURE 30: PDI LEVEL-1A DATASTRIP STRUCTURE .....	174
FIGURE 31: PDI LEVEL-1A DATASTRIP PHYSICAL FORMAT .....	176
FIGURE 32: LEVEL-1A DATASTRIP - GENERAL_INFO DIAGRAM .....	179
FIGURE 33 : LEVEL-1A DATASTRIP – IMAGE_DATA_INFO DIAGRAM .....	182
FIGURE 34: LEVEL-1A DATASTRIP – SATELLITE Ancillary_DATA_INFO DIAGRAM .....	187
FIGURE 35 : LEVEL-1A DATASTRIP – QUALITY_INDICATORS_INFO DIAGRAM .....	188
FIGURE 36 : LEVEL-1A DATASTRIP – AUXILIARY_DATA_INFO DIAGRAM .....	191
FIGURE 37: PDI LEVEL-1B GRANULE STRUCTURE .....	202
FIGURE 38: PDI LEVEL-1B GRANULE PHYSICAL FORMAT .....	205
FIGURE 39: LEVEL-1B_GRANULE_METADATA_FILE - GENERAL_INFO DIAGRAM .....	208
FIGURE 40: LEVEL-1B_GRANULE_METADATA_FILE - GEOMETRIC_INFO DIAGRAM .....	211
FIGURE 41: LEVEL-1B_GRANULE_METADATA_FILE – QUALITY_INDICATORS_INFO DIAGRAM .....	214
FIGURE 42: PDI LEVEL-1B DATASTRIP STRUCTURE .....	217
FIGURE 43: PDI LEVEL-1B DATASTRIP PHYSICAL FORMAT .....	219
FIGURE 44 : LEVEL-1B DATASTRIP – IMAGE_DATA_INFO DIAGRAM .....	222
FIGURE 45: LEVEL-1B DATASTRIP – QUALITY_INDICATORS_INFO DIAGRAM .....	227
FIGURE 46 : LEVEL-1B DATASTRIP – AUXILIARY_DATA_INFO DIAGRAM .....	230



FIGURE 47: PDI LEVEL-1C TILE STRUCTURE.....	241
FIGURE 48: PDI LEVEL-1C TILE PHYSICAL FORMAT.....	244
FIGURE 49: LEVEL-1C_TILE_METADATA_FILE - GENERAL_INFO DIAGRAM.....	248
FIGURE 50: LEVEL-1C_TILE_METADATA_FILE - GEOMETRIC_INFO DIAGRAM.....	250
FIGURE 51: LEVEL-1C_TILE_METADATA_FILE – QUALITY_INDICATORS_INFO DIAGRAM.....	252
FIGURE 52: PDI LEVEL-1C DATASTRIP STRUCTURE.....	263
FIGURE 53: PDI LEVEL-1C DATASTRIP PHYSICAL FORMAT.....	265
FIGURE 54 : LEVEL-1C DATASTRIP – IMAGE_DATA_INFO DIAGRAM.....	267
FIGURE 55: LEVEL-1C DATASTRIP – QUALITY_INDICATORS_INFO DIAGRAM.....	271
FIGURE 56 : LEVEL-1C DATASTRIP – AUXILIARY_DATA_INFO DIAGRAM.....	274
FIGURE 57: PDI LEVEL-2A TILE STRUCTURE.....	284
FIGURE 58: LEVEL-2A TILE STRUCTURE.....	287
FIGURE 59: LEVEL-2A TILE STRUCTURE.....	288
FIGURE 60: LEVEL-2A_TILE_METADATA_FILE - GENERAL_INFO DIAGRAM.....	290
FIGURE 61: LEVEL-2A_TILE_METADATA_FILE – QUALITY_INDICATORS_INFO DIAGRAM.....	291
FIGURE 62: LEVEL-2A TILE IMG_DATA FOLDER STRUCTURE.....	293
FIGURE 63: LEVEL-2A TILE QI_DATA FOLDER STRUCTURE.....	297
FIGURE 64: LEVEL-2A TILE AUX_DATA FOLDER STRUCTURE.....	298
FIGURE 65: PDI LEVEL-2A DATASTRIP STRUCTURE.....	298
FIGURE 66: PDI LEVEL-2A DATASTRIP PHYSICAL FORMAT.....	300
FIGURE 67: S2 HKTМ PDI DEFINITION.....	308
FIGURE 68: S2 SAD PDI DEFINITION.....	310
FIGURE 69: TCI PDI DEFINITION.....	312
FIGURE 70: LEVEL-0 USER PRODUCT STRUCTURE.....	326
FIGURE 71 : LEVEL-0 PRODUCT_METADATA_FILE - GENERAL_INFO DIAGRAM.....	336
FIGURE 72: LEVEL-0 PRODUCT_METADATA_FILE – GEOMETRIC_INFO DIAGRAM.....	345
FIGURE 73 : LEVEL-0 PRODUCT_METADATA_FILE – AUXILIARY_DATA_INFO DIAGRAM.....	348
FIGURE 74 : LEVEL-0_PRODUCT_METADATA_FILE – QUALITY_INDICATORS_INFO DIAGRAM.....	350
FIGURE 75: LEVEL-1A USER PRODUCT STRUCTURE.....	366
FIGURE 76 : EXAMPLE OF LEVEL-1A GRANULE (IMAGE DATA) CORRESPONDING TO DETECTOR 1.....	367
FIGURE 77 : LEVEL-1A PRODUCT_METADATA_FILE - GENERAL_INFO DIAGRAM.....	374
FIGURE 78: LEVEL-1A PRODUCT_METADATA_FILE – GEOMETRIC_INFO DIAGRAM.....	377
FIGURE 79 : LEVEL-1A PRODUCT_METADATA_FILE – AUXILIARY_DATA_INFO DIAGRAM.....	378
FIGURE 80 : LEVEL-1A PRODUCT_METADATA_FILE – QUALITY_INDICATORS_INFO DIAGRAM.....	379
FIGURE 81 : EXAMPLE OF LEVEL-1A GRANULES AGGREGATION.....	382
FIGURE 82: LEVEL-1B USER PRODUCT STRUCTURE.....	395
FIGURE 83 : LEVEL-1B PRODUCT_METADATA_FILE - GENERAL_INFO DIAGRAM.....	402
FIGURE 84: LEVEL-1B PRODUCT_METADATA_FILE – GEOMETRIC_INFO DIAGRAM.....	405
FIGURE 85 : LEVEL-1B PRODUCT_METADATA_FILE – AUXILIARY_DATA_INFO DIAGRAM.....	406
FIGURE 86: LEVEL-1C USER PRODUCT STRUCTURE.....	411
FIGURE 87: LEVEL-1C TILING CONCEPT IN UTM.....	412
FIGURE 88 : LEVEL-1C_PRODUCT_METADATA_FILE - GENERAL_INFO DIAGRAM.....	420
FIGURE 89 : LEVEL-1C_PRODUCT_METADATA_FILE – AUXILIARY_DATA_INFO DIAGRAM.....	423
FIGURE 90: TILE PAIRS CONSOLIDATION.....	427
FIGURE 91: LEVEL-1C USER PRODUCT DECOMPOSITION.....	450
FIGURE 92: LEVEL-1C SINGLE TILE USER PRODUCT PHYSICAL FORMAT.....	451
FIGURE 93: LEVEL-2A PRODUCT PHYSICAL FORMAT.....	456
FIGURE 94: EXAMPLE OF LEVEL-2A PRODUCT TILED IN SEVERAL FILES.....	457
FIGURE 95: LEVEL-2A USER PRODUCT STRUCTURE.....	461

FIGURE 96: LEVEL-2A_PRODUCT_METADATA_FILE - GENERAL_INFO DIAGRAM.....	463
FIGURE 97: LEVEL-2A_PRODUCT_METADATA_FILE – AUXILIARY_DATA_INFO DIAGRAM.....	465
FIGURE 98: LEVEL-2A_PRODUCT_METADATA_FILE – QUALITY_INDICATORS_INFO DIAGRAM .....	466
FIGURE 99: LEVEL-2A USER PRODUCT DECOMPOSITION.....	468
FIGURE 100: LEVEL-2A SINGLE TILE USER PRODUCT PHYSICAL FORMAT.....	468
FIGURE 101: HMI OF INSPIRE METADATA EDITOR .....	472
FIGURE 102 : VOLUME FOR IMAGE 290KM X 290KM, ESTIMATED WITH AVERAGE JP2000 COMPRESSION RATIO).....	509

### Table of Tables

TABLE 1: DATATAKE_ID DEFINITION .....	42
TABLE 2: SENTINEL-2 PRODUCT LEVELS AND MAIN CHARACTERISTICS .....	50
TABLE 3: TYPE OF PDI.....	55
TABLE 4: PDI FILE NAME DECOMPOSITION .....	56
TABLE 5: GRANULE (TILE), DATASTRIP AND TCI PDI FILE TYPE .....	57
TABLE 6: GIPP FILE TYPE .....	58
TABLE 7: DEM FILE TYPE.....	58
TABLE 8: GRI FILE TYPE.....	59
TABLE 9: HKTМ FILE TYPE.....	59
TABLE 10: SAD PACKET TYPE POSSIBLE VALUES .....	59
TABLE 11: SAD FILE TYPE.....	60
TABLE 12: IERS BULLETIN FILE TYPE.....	60
TABLE 13: POD FILE TYPE.....	60
TABLE 14: ECMWF FILE TYPE .....	60
TABLE 15: GRANULE / TILE METADATA STRUCTURE .....	64
TABLE 16: GRANULE / TILE PDI GENERAL_INFO .....	65
TABLE 17: GRANULE / TILE PDI GEOMETRIC_INFO .....	65
TABLE 18: GRANULE / TILE PDI QUALITY INDICATORS .....	72
TABLE 19: GRANULE QUALITY CONTROL CHECKS.....	73
TABLE 20:HIGH LEVEL STRUCTURE OF SAFE MANIFEST FILE .....	77
TABLE 21: DATASTRIP METADATA STRUCTURE.....	80
TABLE 22: DATASTRIP PDI GENERAL_INFO .....	81
TABLE 23: DATASTRIP PDI IMAGE_DATA_INFO .....	81
TABLE 24: DATASTRIP PDI SATELLITE Ancillary_DATA_INFO .....	82
TABLE 25: DATASTRIP PDI QUALITY INDICATORS .....	84
TABLE 26: DATASTRIP QUALITY CONTROL CHECKS .....	85
TABLE 27: DATASTRIP PDI AUXILIARY_DATA_INFO.....	86
TABLE 28: LEVEL-0 GRANULE_METADATA_FILE - GENERAL_INFO DESCRIPTION.....	97
TABLE 29: LEVEL-0 GRANULE_METADATA_FILE - GEOMETRIC_INFO DESCRIPTION .....	100
TABLE 30: LEVEL-0 GRANULE - QUALITY_INDICATORS_INFO DESCRIPTION .....	102
TABLE 31 – CONTENT OF INFORMATION PACKAGE MAP FOR PDI LEVEL-0 GRANULE SAFE MANIFEST ...	107
TABLE 32 - CONTENT OF METADATA SECTION FOR PDI LEVEL-0 GRANULE SAFE MANIFEST .....	114
TABLE 33 – CONTENT OF DATA OBJECT SECTION FOR PDI LEVEL-0 GRANULE SAFE MANIFEST.....	114
TABLE 34: LEVEL-0 DATASTRIP - GENERAL_INFO DESCRIPTION .....	124
TABLE 35: LEVEL-0 DATASTRIP – IMAGE_DATA_INFO DESCRIPTION .....	128
TABLE 36: LEVEL-0 DATASTRIP – SATELLITE Ancillary_DATA_INFO DESCRIPTION.....	136
TABLE 37: LEVEL-0 DATASTRIP – QUALITY_INDICATORS_INFO DESCRIPTION .....	140
TABLE 38: LEVEL-0 DATASTRIP – AUXILIARY_DATA_INFO DESCRIPTION.....	142

TABLE 39 - CONTENT OF METADATA SECTION FOR PDI LEVEL-0 DATASTRIP SAFE MANIFEST .....	151
TABLE 40: LEVEL-1A_GRANULE_METADATA_FILE - GENERAL_INFO DESCRIPTION .....	160
TABLE 41: LEVEL-1A_GRANULE_METADATA_FILE - GEOMETRIC_INFO DESCRIPTION .....	163
TABLE 42: LEVEL-1A_GRANULE_METADATA_FILE – QUALITY_INDICATORS_INFO DESCRIPTION .....	165
TABLE 43- CONTENT OF METADATA SECTION FOR PDI LEVEL-1A GRANULE SAFE MANIFEST .....	173
TABLE 44: LEVEL-1A DATASTRIP - GENERAL_INFO DESCRIPTION .....	181
TABLE 45: LEVEL-1A DATASTRIP – IMAGE_DATA_INFO DESCRIPTION.....	186
TABLE 46: LEVEL-1A DATASTRIP – SATELLITE Ancillary_DATA_INFO DESCRIPTION.....	187
TABLE 47: LEVEL-1A DATASTRIP - QUALITY_INDICATORS_INFO DESCRIPTION.....	190
TABLE 48: LEVEL-1A DATASTRIP – AUXILIARY_DATA_INFO DESCRIPTION .....	192
TABLE 49 - CONTENT OF METADATA SECTION FOR PDI LEVEL-1A DATASTRIP SAFE MANIFEST .....	201
TABLE 50: LEVEL-1B_GRANULE_METADATA_FILE - GENERAL_INFO DESCRIPTION .....	210
TABLE 51: LEVEL-1B_GRANULE_METADATA_FILE - GEOMETRIC_INFO DESCRIPTION .....	213
TABLE 52: LEVEL-1B_GRANULE_METADATA_FILE – QUALITY_INDICATORS_INFO DESCRIPTION .....	215
TABLE 53: LEVEL-1B DATASTRIP – IMAGE_DATA_INFO DESCRIPTION.....	226
TABLE 54: LEVEL-1B DATASTRIP – QUALITY_INDICATORS_INFO DESCRIPTION .....	229
TABLE 55: LEVEL-1B DATASTRIP – AUXILIARY_DATA_INFO DESCRIPTION .....	231
TABLE 56 - CONTENT OF METADATA SECTION FOR PDI LEVEL-1B DATASTRIP SAFE MANIFEST .....	240
TABLE 57: LEVEL-1C_TILE_METADATA_FILE - GENERAL_INFO DESCRIPTION.....	249
TABLE 58: LEVEL-1C_TILE_METADATA_FILE - GEOMETRIC_INFO DESCRIPTION .....	251
TABLE 59: LEVEL-1C_TILE_METADATA_FILE – QUALITY_INDICATORS_INFO DESCRIPTION .....	253
TABLE 60 CONTENT OF METADATA SECTION FOR PDI LEVEL-1C TILE SAFE MANIFEST .....	262
TABLE 61: LEVEL-1C DATASTRIP – IMAGE_DATA_INFO DESCRIPTION.....	270
TABLE 62: LEVEL-1C DATASTRIP – QUALITY_INDICATORS_INFO DESCRIPTION .....	272
TABLE 63: LEVEL-1C DATASTRIP – AUXILIARY_DATA_INFO DESCRIPTION .....	275
TABLE 64 - CONTENT OF METADATA SECTION FOR PDI LEVEL-1C DATASTRIP SAFE MANIFEST .....	283
TABLE 65: LEVEL-2A_TILE_METADATA_FILE – QUALITY_INDICATORS_INFO DESCRIPTION.....	292
TABLE 66: LEVEL-2A IMAGE FILES NAMING CONVENTION .....	294
TABLE 67: PDI-ID DEFINITION FOR GIPP FILES .....	303
TABLE 68: PDI-ID DEFINITION FOR DEM .....	304
TABLE 69: PDI-ID DEFINITION FOR IERS BULLETIN .....	306
TABLE 70: PDI-ID DEFINITION FOR SAD .....	311
TABLE 71: SENTINEL-2 PRODUCTS PHYSICAL FORMAT.....	315
TABLE 72: MAIN PRODUCT DIRECTORY - NAMING CONVENTION .....	318
TABLE 73: PRODUCT_METADATA_FILE - NAMING CONVENTION .....	319
TABLE 74: PRODUCT_METADATA_FILE - NAMING CONVENTION .....	320
TABLE 75: HIGH LEVEL STRUCTURE OF SAFE MANIFEST FILE .....	324
TABLE 76: DFEP ANNOTATIONS FOR ONE INSTRUMENT SOURCE PACKET .....	329
TABLE 77: NUMBER OF MISSION SOURCE PACKETS IN A GRANULE .....	330
TABLE 78: LEVEL-0 PRODUCT METADATA .....	332
TABLE 79: LEVEL-0 PRODUCT_METADATA_FILE - GENERAL_INFO DESCRIPTION .....	344
TABLE 80: LEVEL-0 PRODUCT_METADATA_FILE - GEOMETRIC_INFO DESCRIPTION.....	347
TABLE 81: LEVEL-0 PRODUCT_METADATA_FILE – AUXILIARY_DATA_INFO DESCRIPTION .....	349
TABLE 82: LEVEL-0 PRODUCT_METADATA_FILE – QUALITY_INDICATORS_INFO DESCRIPTION.....	352
TABLE 83 - CONTENT OF METADATA SECTION FOR LEVEL-0 USER PRODUCT SAFE MANIFEST .....	363
TABLE 84: INPUT FOR LEVEL-1A PROCESSING.....	365
TABLE 85: NUMBER OF LINES IN ONE GRANULE .....	367
TABLE 86: LEVEL-1A PRODUCT METADATA .....	370
TABLE 87: LEVEL-1A PRODUCT_METADATA_FILE - GENERAL_INFO DESCRIPTION.....	375

TABLE 88 - CONTENT OF METADATA SECTION FOR LEVEL-1A USER PRODUCT SAFE MANIFEST ..... 393

TABLE 89: INPUT FOR LEVEL-1B PROCESSING ..... 394

TABLE 90: LEVEL-1B PRODUCT METADATA ..... 398

TABLE 91: LEVEL-1B PRODUCT\_METADATA\_FILE - GENERAL\_INFO DESCRIPTION ..... 404

TABLE 92: LEVEL-1B PRODUCT\_METADATA\_FILE - AUXILIARY\_INFO DESCRIPTION ..... 406

TABLE 93: INPUT OF LEVEL-1C PROCESSING ..... 410

TABLE 94: LEVEL-1C PRODUCT METADATA ..... 416

TABLE 95: LEVEL-1C\_PRODUCT\_METADATA\_FILE - GENERAL\_INFO DESCRIPTION ..... 421

TABLE 96: LEVEL-1C\_PRODUCT\_METADATA\_FILE - AUXILIARY\_INFO DESCRIPTION ..... 423

TABLE 97- CONTENT OF METADATA SECTION FOR LEVEL-1C USER PRODUCT SAFE MANIFEST ..... 437

TABLE 98: LEVEL-2A PRODUCT METADATA ..... 460

TABLE 99: LEVEL-2A\_PRODUCT\_METADATA\_FILE - GENERAL\_INFO DESCRIPTION ..... 464

TABLE 100: LEVEL-2A\_PRODUCT\_METADATA\_FILE - AUXILIARY\_INFO DESCRIPTION ..... 466

TABLE 101: LEVEL-2A\_PRODUCT\_METADATA\_FILE - QUALITY\_INDICATORS\_INFO DESCRIPTION ..... 466

TABLE 102: LEVEL-2A TILE ID – NAMING CONVENTION ..... 467

TABLE 103: LEVEL-2A DATASTRIP\_ID – INSTANCE\_ID NAMING CONVENTION ..... 468

TABLE 104: LEVEL-2A SINGLE TILE PRODUCT NAME NOMENCLATURE ..... 469

PAGE INTENTIONALLY LEFT BLANK

## 1. INTRODUCTION

### 1.1 Purpose of the document

The purpose of the Sentinel-2 Products Specification Document (PSD) is to describe in detail the mission User Products.

The Sentinel-2 mission User Products are: Level-0, Level-1A, Level-1B, Level-1C and Level-2A.

The specification of the Sentinel-2 User Products includes the description of the Product Data Items (PDI) composing them.

Annexed to this document are provided two zip files:

1. S2-PDGS-TAS-DI-PSD-V14.4\_Schema.zip
2. S2-PDGS-TAS-DI-PSD-V14.4\_SAFE.zip

The first zip file contains the XSD schema describing the metadata and physical structure of the PDIs (as outlined in Chapter-2) and User Products (as outlined in Chapter-4).

The second zip file includes an example of SAFE Manifest for each PDI and User Product and the corresponding xfdx.xsd schema used to validate them.

### 1.2 Document Organisation and Main Index

This document is structured as follows:

- Chapter 1: *Introduction*, provides the purpose and this overview of the document, the list of applicable and reference documents, a roadmap to help the reader navigating through the document, the list of the used acronyms. In addition this chapter provides the high level description of the Sentinel-2 Mission and User Products characteristics.
- Chapter 2: *Sentinel-2 Product Definitions*, regroups all definitions and concepts relevant to the product format definition;
- Chapter 3: *PDI Format Definition*, provides a detailed description of the sub-structures used in the final product format;
- Chapter 4: *User Product Physical Format Definition*, provides a detailed description of the Product format for all product types, and including references to the information grouped in the previous chapters as applicable.

Sentinel-2 Product users are consequently invited to browse the format definitions starting from the root structures described in **Chapter 4** and then descend the hierarchy to learn the more detailed elements or concepts by following the references from Chapter-4 to the previous chapters.

The following table provides a general and per product-level summary index to the main relevant sections:

<b>Executive Summary</b>		<b>Section pointer</b>
General Product elements terms and definitions		Chapter 2
Common organisation and structure	User Product	4.1
	Granule/Tile PDI	3.4
	Datastrip PDI	3.5
Naming	User Product	4.2
	PDIs	3.2
<b>Level-0</b>	User Product	4.6.7
	Granule PDI	3.5.7
	Datastrip PDI	3.6.2
<b>Level-1A</b>	User Product	4.7.7
	Granule PDI	3.7.2
	Datastrip PDI	3.8.2
<b>Level-1B</b>	User Product	4.8.7
	Granule PDI	3.9.2
	Datastrip PDI	3.10.2
<b>Level-1C</b>	User Product	4.9.7
	Tile PDI	3.11.2
	Datastrip PDI	3.12.2
<b>Level-2A</b>	User Product	4.10.7
	Tile PDI	3.13
	Datastrip PDI	3.14

### 1.3 Reference Documents

The documents referenced from or of specific relevance to this document are listed hereafter.

Identifier	Reference	Version	Date	Title
SAFE-SPEC	GAEL-P264-DOC-0001-01-01	1.3	26/06/2014	Sentinel Standard Archive Format for Europe (sentinel safe) Control Book – volume 1 – Core Specifications
HMA-GML	OGC 07-036		27/08/2007	Geography Markup Language (GML) 3.2.1 Encoding Standard
EC-INSPIRE-DIR	DIRECTIVE 2007/2/EC		14.03.2007	DIRECTIVE-2007-2-EC (INSPIRE) - Establishing an Infrastructure for Spatial Information
EC-INSPIRE-CR	REGULATION 2008/12/EC		24.12.2008	REGULATION-EC-1205-2008 (INSPIRE) - Implementing Directive 2007-2-EC as regards Metadata
SAFE				Standard Archive Format for Europe (SAFE), <a href="http://earth.esa.int/SAFE/">http://earth.esa.int/SAFE/</a>
DIMAP				DIMAP Format Specifications, <a href="http://www.spotimage.fr/dimap/spec/dimap.htm">http://www.spotimage.fr/dimap/spec/dimap.htm</a>
S2GICD	GS2.ICD.ASD.SY.00006	9.0	04.03.2014	Satellite to Ground Segment Interface Control Document
S2GICD-MSI	GS2.ICD.ASF.MSI.00008	8.0	15/01/2013	MSI Mission Data ICD
DFEP-ICD	DFEP-ICD-KSAC-ESA-1066	1.8	19/10/2012	Sentinel DFEP External ICD – Volume 2
S2GICD-SAD	GS2.ICD.ASD.SY.00012	9.0	15/04/2014	Sentinel 2 Satellite Ancillary Data Interface Control Document
EOFFS-PDGS	GMES-GSEG-EOPG-TN-10-0099	1.2	25/06/2013	Earth Observation GS File Format Standard – Tailoring for the Sentinel Missions PDGS
EOFFS	PE-TN-ESA-GS-0001	2.0	07/03/2011	Earth Observation Ground Segment File Format Standard
MRD	EOP-SM/1163/MR-dr	2.1	08.03.2010	Mission Requirements Document
ECMWF-FCAST				ECMWF Deterministic Atmospheric Model Products
GRIB	GRIB Edition 1			A GUIDE TO THE CODE FORM FM 92-IX Ext.  <a href="http://www.wmo.int/pages/prog/www/WMO_Codes/Guides/GRIB/GRIB1-Contents.html">http://www.wmo.int/pages/prog/www/WMO_Codes/Guides/GRIB/GRIB1-Contents.html</a>
GRI-FFS	GMES-S2GS-EOPG-TN-13-0004	1.1	15/10/2014	Sentinel-2 GRI Format Specification Document



Identifier	Reference	Version	Date	Title
GMLJP2	OGC 05-047r3			GML in JPEG2000 for Geographic Imagery (GMLJP2) Encoding Specification <a href="http://www.opengeospatial.org/standards/gmljp2">http://www.opengeospatial.org/standards/gmljp2</a>
JP2STD	ISO/IEC 15444-1		2004	JPEG 2000 standard part 1 and part 2, <a href="http://www.jpeg.org/jpeg2000">http://www.jpeg.org/jpeg2000</a>
OLQC-GIPP	GAEL-P268-TCN-001	1.1	2012-12-11	OLQC-GIPP interface
POD-FFS	GMES-GSEG-EOPG-FS-10-0075	1.7	20/12/2013	GMES Sentinels Precise Orbit Determination (POD) Service: OFL POD Service and NRT POD Facility File Format Specifications
EOM-OGC	OGC 10-157r3	1.0	2011-12-01	Earth Observation Metadata profile of Observations & Measurements

## 1.4 Acronyms

Specific abbreviations used in this document are given below.

Acronym	Definition
AOCS	Attitude and Orbit Control System
CGS	Core Ground Segment
CNES	Centre National d'Études Spatiales
DAP	Data Access Portfolio
DEM	Digital Elevation Model
DIMAP	Digital Image MAP
DTED	Digital Terrain Elevation Data
ECMWF	European Centre for Medium-Range Weather Forecasts
ESA	European Space Agency
EO	Earth Observation
FEE	Front End Electronic
FPA	Focal Plane Assembly
GCP	Ground Control Point
GIPP	Ground Image Processing Parameter
GMES	Global Monitoring for Environment and Security (former appellation of the 'Copernicus' Programme)
GML	Geography Markup Language
GPS	Global Positioning System
GRI	Global Reference Images
HKTM	House Keeping Telemetry
IAD	Image Ancillary Data
ICD	Interface Control Document
IDP-SC	Instrument Data Processing Software Component
INSPIRE	Infrastructure for Spatial Information in Europe
ISO	International Organization for Standardization
ISP	Instrument Source Packet
JPIP	JPEG2000 Interactive Protocol
JP2	JPEG2000 format
MRD	Sentinel-2 Mission Requirements Document
MSI	Multi-Spectral Instrument
NRT	Near-Real-Time
NUC	Non-Uniformity Coefficients
OLIB	On-Line Image Browser
OLQC	On-Line Quality Control
PDI	Product Data Item
PDGS	Payload Data Ground Segment
PVI	PreView Image
QC	Quality-Control
QI	Quality Indicator
QL	Quick-Look
SAFE	Standard Archive Format for Europe
SRTM	Shuttle Radar Topographic Mission
SSD	Spatial Sampling Distance
SWIR	Short Wave Infra-Red
TBD	To Be Defined
TCI	True Colour Image
TDI	Time Delay and Integration



## Sentinel-2 Products Specification Document

REF : S2-PDGS-TAS-DI-PSD  
ISSUE : 14.5  
DATE : 14/03/2018  
PAGE : 35 / 510

TOA	Top-Of-Atmosphere
US-MGRS	US-Military Grid Reference System
UTM	Universal Transverse Mercator
VNIR	Visible and Near Infrared
WGS	World Geodetic System
WICOM	Wavelet Image Compression Modules



## 1.5 Sentinel-2 Mission Overview

Sentinel-2 Mission is an European earth polar-orbiting satellite constellation (Sentinel-2A and 2B) designed to feed the GMES system with continuous and operational high-resolution imagery for the global and sustained monitoring of Earth land and coastal areas.

The Sentinel-2 system is based on the concurrent operations of two identical satellites flying on a single orbit plane but phased at 180°, each hosting a Multi-Spectral Instrument (MSI) covering from the visible to the shortwave infrared spectral range and delivering high spatial resolution imagery at global scale and with a high revisit frequency.

The MSI aims at measuring the earth reflected radiance through the atmosphere in 13 spectral bands spanning from the Visible and Near Infra-Red (VNIR) to the Short Wave Infra-Red (SWIR):

- 4 bands at 10m: blue (490nm), green (560nm), red (665nm) and near infrared (842nm).
- 6 bands at 20m: 4 narrow bands for vegetation characterisation (705nm, 740nm, 783nm and 865nm) and 2 larger SWIR bands (1610nm and 2190nm) for applications such as snow/ice/cloud detection or vegetation moisture stress assessment.
- 3 bands at 60m mainly for cloud screening and atmospheric corrections (443nm for aerosols, 945 for water vapour and 1375nm for cirrus detection).

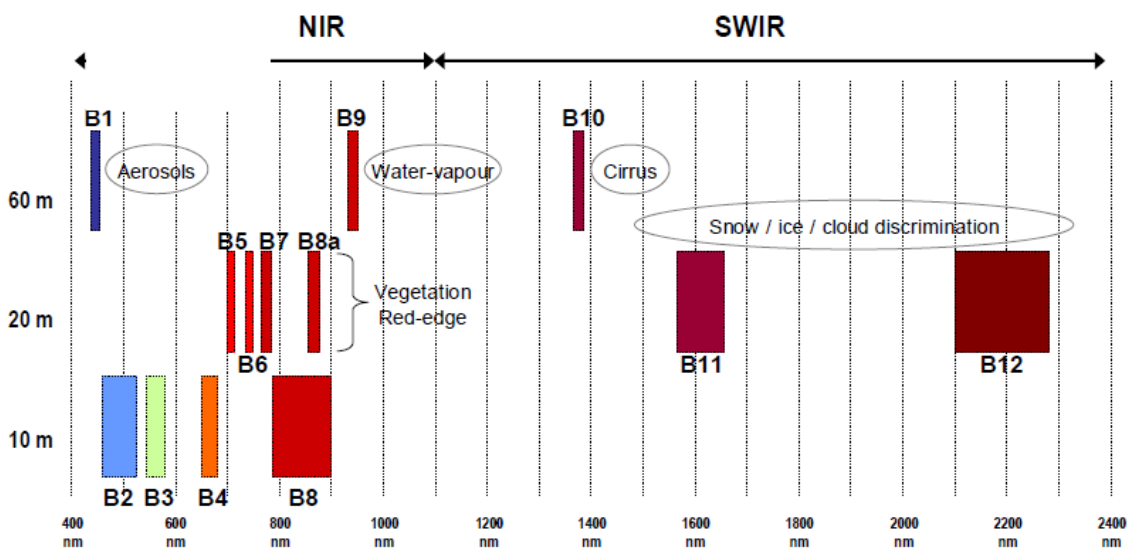

Figure 1: MSI Spectral-Bands versus Spatial Resolution

The MSI instrument design has been driven by the large swath requirements together with the high geometrical and spectral performance of the measurements.

It is based on a telescope feeding two focal planes spectrally separated.

Two distinct arrays of 12 optical detectors mounted on each focal plane cover respectively the VNIR and SWIR channels.

The 12 detectors on each focal plane are staggered-mounted to cover altogether the 20.6° instrument field of view resulting in a compound swath width of 290km on the ground-track.

As described in the following figure, because of the staggered positioning of the detectors on the focal planes, a parallax angle between the two alternating odd and even clusters of detectors is induced on the measurements resulting in a shift along-track of about 46km (maximum) inter-detector. Likewise, the hardware design of both the VNIR and SWIR detectors imposes a relative displacement of each spectral channel sensor within the detector resulting in an inter-band measurement parallax amounting to a maximum along-track displacement of about 14km.

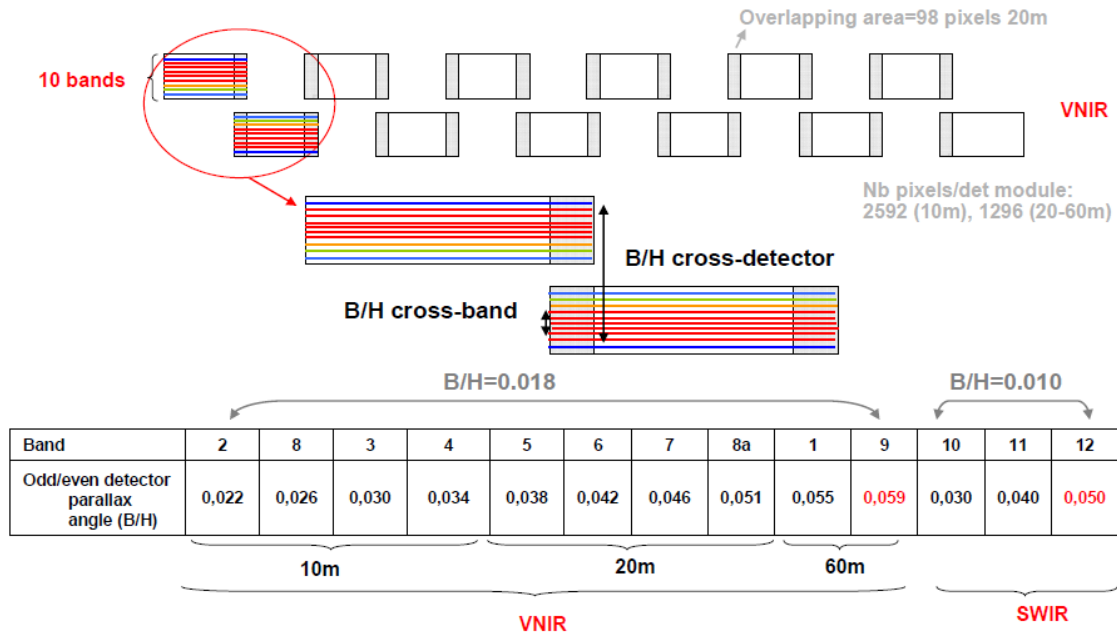

Figure 2: Staggered detector configuration and inter-detector/inter-band parallax angles

The Sentinel-2 mission objectives include the operational supply of optical data, with high revisit frequency, coverage, timeliness and reliability, for services such as:

- Risk Management (floods and forest fires, subsidence and land slides)
- European Land Use/Land Cover State and Changes
- Forest Monitoring
- Food Security/Early Warning Systems
- Water Management and Soil Protection
- Urban Mapping
- Natural Hazards
- Terrestrial Mapping for Humanitarian Aid and Development

Sentinel-2 mission objectives present a new challenge requiring space and ground segment resources in terms of:

- Temporal coverage, which translated into the need for a short orbit repeat cycle (10-days) and for a dual spacecraft operations in twin configuration providing a 5-days revisit frequency;
- Large spatial coverage and high coverage frequency, which translated into the need for a wide swath coverage (290 km) with capabilities of global land masses acquisitions;
- High operation time during the daylight portion of the orbit;

- Wide spectrum optical range (visible to short-wave infrared) including 13 spectral bands;
- Data accessibility to the large Sentinel-2 data volume.

Mission data users include:

- Copernicus Service Projects and European adding value industry
- National users
- Scientific users
- Operational Meteorological users
- ESA Climate Change Initiative Programme users
- Sentinel-2 calibration and validation users
- International partners with granted access to Sentinel-2 real-time data downlinks
- Other users supported by the ESA data policy

## 1.6 Sentinel-2 Product Overview

The Sentinel-2 **User Product** is defined by a collection of data items (image, ancillary, auxiliary data) and metadata describing all elements composing the product.

The product data items and the metadata are selectable through a user download options (cf. section 4.4).

The User Product physical structure is defined in the Chapter 4.

### 1.6.1 User Product General Description

The **User Product** is the product delivered to the user corresponding to:

- A user defined geographical Area-Of-Interest;
- A user defined selection of the User Product components specified as download options (cf. section 4.4) according to different user needs and authorizations.

The User Product is composed by a set of Granules (also called Tiles for L1C User Product) intersecting/touching the Area-Of-Interest defined by the user. A Granule is the minimum indivisible partition of a User Product (containing all possible spectral bands).

The following figure illustrates the User Product concept for the L1C User Product that aggregates all Tiles corresponding to the user defined Area-Of-Interest.

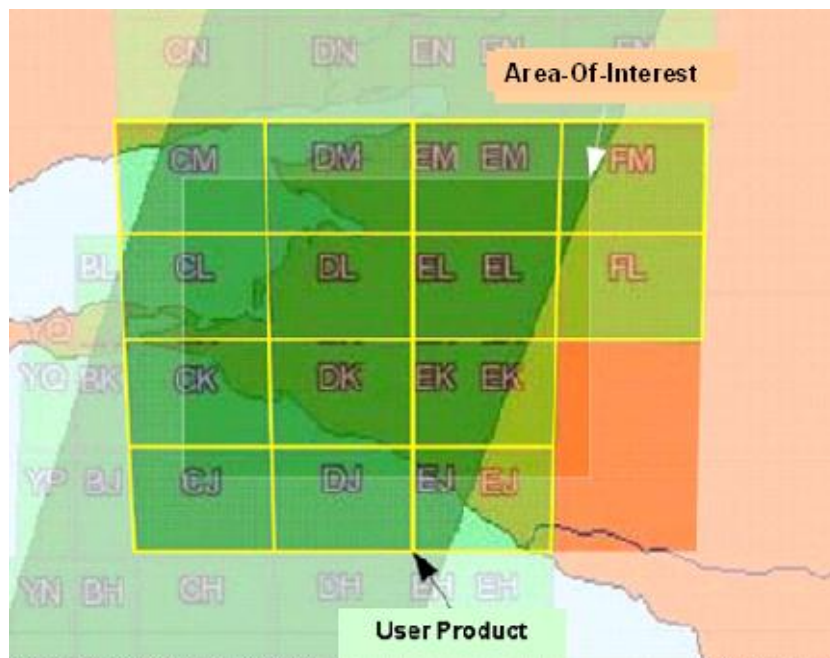

Figure 3: L1C User Product aggregating all Tiles intersecting a user defined Area-Of-Interest

The S2 User Products are hence composed by a compilation of physical product components referred as **Product Data Items** (PDI) corresponding to the minimum indivisible partition of one Sentinel-2 User Product.

A PDI is a self standing atomic piece of processing-related data:

- **self standing**: it is formed by data and metadata, the meta data fully describing the data allowing to handle it as a whole,
- **atomic**: a PDI is never split in smaller pieces until download time (where the user may decide to get only a subset of bands for instance),
- **processing-related data**: it can be of Granule type, Tile type, Datastrip type, Ancillary or Auxiliary data type (cf. section 3.1),
- **univocally identified**: a PDI is identified and referenced by a unique PDI ID.

Each PDI is composed by a set or an excerpt of PDI elements:

- Image data (MSI data);
- Image metadata;
- Image quality reports including quality data indicators and quality checks;
- Auxiliary data;
- Satellite Ancillary data;
- Preview Image data.

The User Product will include only the selected PDI elements.

### 1.6.2 User Product Format

The User Product is formatted by default as a **SENTINEL - SAFE** (Standard Archive Format for Europe) product.

The **SAFE** has been designed to act as a common format for archiving data within ESA Earth Observation archiving facilities and for distributing data to End Users.

SAFE benefits from the experience gathered while developing standards related to data formats.

SAFE intends to resolve the major challenges coming from the packaging and the long-term preservation of Earth Observation data. Special attention has been taken to ensure that SAFE conforms to the ISO 14721:2003 OAIS (Open Archival Information System) reference model and related standards such as the emerging CCSDS/ISO XFDU (XML Formatted Data Units) packaging format.

In order to address the specific needs of Sentinel data, a particular "version" of the SAFE format has been adopted, named "SAFE for Sentinels" (cf. [SAFE-SPEC]), developed to act as a standard format for Sentinels platform data; it can be defined a "SAFE - like" format, where a few new types specific to Sentinels and different constraints on existing types have been introduced.



In addition to the SAFE format used as baseline to package a S2 User Product, the user will have the possibility to select an other optional output format based on **DIMAP** (Digital Image MAP) format (cf. [DIMAP]).

In this document the S2 SAFE User Product format is presented and in Annex A the differences with respect to S2 DIMAP User Product format are described.

Finally, it is important to note that Sentinel-2 User Products is compliant to the **INSPIRE** (Infrastructure for Spatial Information in the European Community) Metadata regulation (cfr. [EC-INSPIRE-CR] and [EC-INSPIRE-DIR]).

INSPIRE is an European Union initiative to establish an infrastructure for spatial information in Europe that helps to make spatial or geographical information more accessible and interoperable for a wide range of purposes. The Sentinel-2 datasets in their inherent quality of describing spatial data are fully entitled to comply with the directive and hence the INSPIRE Metadata directive applies in entirety to the Sentinel-2 products. More details about INSPIRE Metadata regulation are in the Annex B of the document.

### 1.6.3 Complete Single Tile Products (Level-1C and Level-2A)

Complete Single Tile Products are a specific type of User Products applicable to Level-1C and Level-2A product types that can be created according to a specific download option. Complete Single Tile Products have the following individual characteristics:

- One Level-1C (resp. Level-2A) Complete Single Tile User Product embeds a single Level-1C (resp. Level-2A) Tile PDI element, and consequently covers solely the geographical area of the corresponding Tile.
- As opposed to other User Products, every Complete Single Tile User Product is invariable with the download instance creating it. The name of a Complete Single Tile Product is consequently unique and explicitly relates to its contents.
- A Complete Single Tile Product invariably embeds all available data structure elements of the generic product package with the sole exception of the Auxiliary Data structures; e.g. all Level-1C spectral band images are included in Level-1C Complete Single Tile products. Auxiliary Data structures and browse images are not embedded in Complete Single Tile products.

## 2. SENTINEL-2 PRODUCT DEFINITIONS

This section aims to presenting some general definitions regarding the User Products:

- Product Levels
- Processing Baseline
- Metadata Management
- Product Data Item (PDI)
- Timeliness definition

### 2.1 Orbit

The term **Orbit** used in this document refers to any specific Sentinel-2 spacecraft orbit. Each satellite will operate in a reference sun-synchronous orbit with a repeat cycle of 10 days for the overall duration of the mission. Sentinel-2A and Sentinel-2B will be in the same orbit allowing a ground-track revisit frequency of 5 days for the dual-spacecraft constellation.

### 2.2 Datatake

The Sentinel-2 User Products will always refer to a given **Datatake**. Datatake definition refers to a continuous acquisition of an image from one Sentinel-2 satellite in a given MSI imaging mode. The maximum length of an imaging Datatake is 15000 km (continuous observation from Northern Russia to Southern Africa) and this is the longest possible product that a user can ask for.

Datatake\_ID identifies univocally a given Datatake.

Datatake\_ID: GS[SS]\_[YYYYMMDDTHMMSS]\_[RRRRRR]\_N[xx.yy]

Field Name	Value/Meaning	Note
SS	2A 2B	Identifies the Sentinel2 satellite
YYYYMMDDTHMMSS	identifies the Datatake Start Time	Fourteen digits, date and time separated by the character T
RRRRRR	000001-999999	Identifies the Absolute Orbit Number
xx.yy	x,y = {0;9}	Processing Baseline (cf. further for the "Processing Baseline" definition).  Note that a reprocessing production generates a new Datatake and consequently a new Datatake_ID.

Table 1: Datatake\_ID Definition

Datatake\_ID example: GS2B\_20141104T134012\_123456\_N01.01

## 2.3 Datastrip

Within a given Datatake, a portion of sensed image downlinked during a pass to a given station is termed **Datastrip**. If a particular orbit is acquired by more than one station, a Datatake is composed of one or more Datastrips.

A Datastrip refers thus to all data corresponding to:

1. a single Datatake;
2. downlinked over a given ground station.

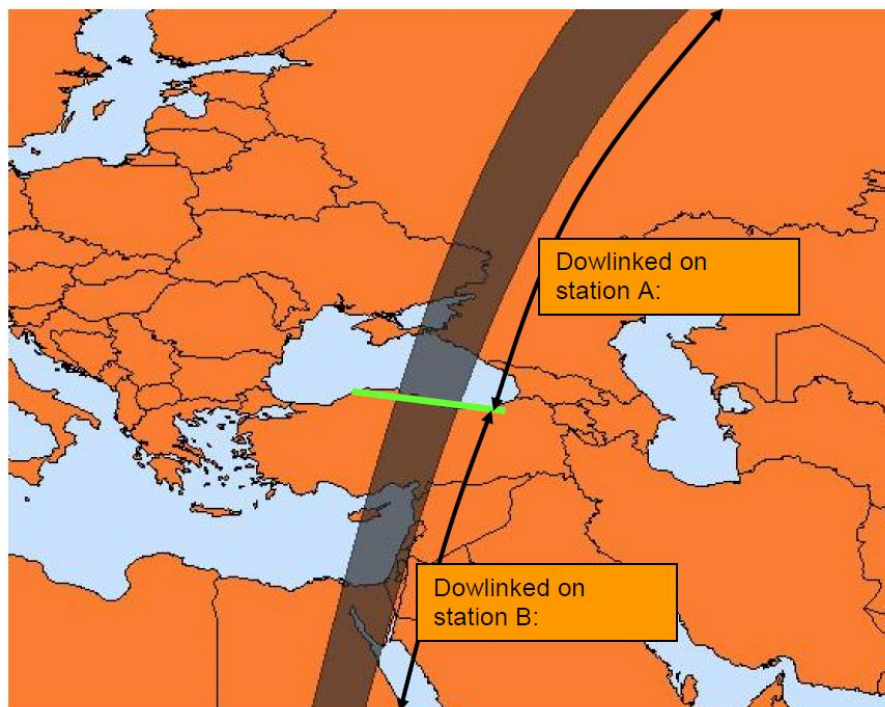

Figure 4: Datatake segmentation in Datastrips

In terms of Datatake and Datastrips a Sentinel-2 User Product may therefore include one or more Datastrips belonging to the same Datatake.

The minimum length of a Datastrip is 92 km corresponding to four on-board scenes (cf. further for the “scene” definition).

The maximum length of a Datastrip is theoretically the maximum length of a Datatake i.e. 15000 km (continuous observation from Northern Russia to Southern Africa).

The Datastrip identifier is a character string that identifies in a unique way a Sentinel-2 acquired Datastrip relatively to a given Datatake.

In the chapter 3, where the Datastrip Product Data Item is described, the Datastrip identifier is defined through the PDI\_ID definition.

## 2.4 MSI Bands

The MSI **Spectral Bands** span from the Visible and the Near Infra-Red to the Short Wave Infra-Red:

- 4 bands at 10m;
- 6 bands at 20m;
- 3 bands at 60m.

The MSI spectral bands are identified by a single integer number. The correspondence between band name and band number is given in the following table.

Band Number	S2A		S2B		Spatial resolution (m)
	Central wavelength (nm)	Bandwidth (nm)	Central wavelength (nm)	Bandwidth (nm)	
<b>1</b>	443.9	27	442.3	45	60
<b>2</b>	496.6	98	492.1	98	10
<b>3</b>	560.0	45	559	46	10
<b>4</b>	664.5	38	665	39	10
<b>5</b>	703.9	19	703.8	20	20
<b>6</b>	740.2	18	739.1	18	20
<b>7</b>	782.5	28	779.7	28	20
<b>8</b>	835.1	145	833	133	10
<b>8a</b>	864.8	33	864	32	20
<b>9</b>	945.0	26	943.2	27	60
<b>10</b>	1373.5	75	1376.9	76	60
<b>11</b>	1613.7	143	1610.4	141	20
<b>12</b>	2202.4	242	2185.7	238	20

This convention is used to identify the spectral bands within the User Product.

## 2.5 MSI Detectors

The MSI includes two focal planes each one hosting two distinct arrays of 12 optical **Detectors** to cover respectively the VNIR and SWIR channels:

- a VNIR focal plane made of 12 staggered detector modules
- a SWIR focal plane made of 12 staggered detector modules.

From an image processing point of view the detectors are identified by 2 digits from 01 to 12. Detectors' images are numbered from 01 to 12 in the left to right order, i.e. from west to east in the case of a descending orbit.

## 2.6 MSI Scene

MSI image data is packaged on-board in a set of instrument source packets called "on-board scene" or "**scene**". This scene corresponds to a simultaneous observation of about 3.6 seconds for all bands and all detectors, which means an approximate coverage on ground of 23km along track, for each band.

Each scene consists then of a deterministic number of CCSDS source packets depending only on the geometric resolution as indicated in the following table:

SSD	Number of packets (strips) per detector and band	Number of detectors	Number of bands	Number of CCSDS packets	Bands
10 m	144	12	4	6912	B2, B8, B3, B4,
20 m	72	12	6	5184	B5, B6, B7, B8a, B11, B12
60 m	24	12	3	864	B1, B9, B10

The MSI instrument can be configured to have data in compressed or by-passed/uncompressed mode in order to fit the downlink bandwidth. Compression by-passed implies that data for only 4 detectors are provided (cf. section 3.5.8.2).

## 2.7 Product Granules

The Sentinel-2 User Product is composed by a set of **Granules**, which are called Tiles for L1C User Products.

### 2.7.1 Granules

MSI products are provided as a compilation along a single orbit of elementary **Granules** of fixed size. In this respect, the product granularity corresponds to the minimum indivisible partition of one Sentinel-2 User Product.

For Level-0, 1A and 1B products, these Granules are sub-images in MSI sensor reference frame of a given number of lines along-track and detector separated. Granules are defined further for each product level type.

All Granules intersecting/touching the Region of Interest of the user are provided into the final User Product.

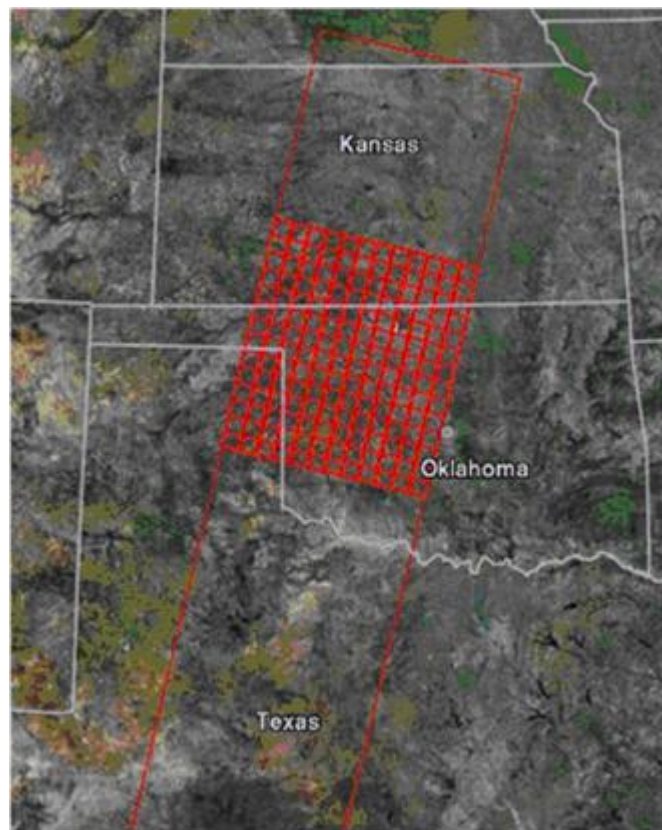

Figure 5: Example of Granules covering an Area-Of-Interest of the User

### 2.7.2 Tiles and UTM Tiled Grid

For ortho-rectified products (Level-1C and Level-2A), the Granules are called **Tiles**. A Tile consists of 100kmx100km squared ortho-images in cartographic reference frame UTM/WGS84 (Universal Transverse Mercator / World Geodetic System 1984) projection.

Ortho-rectified product are systematically projected on UTM-UPS/WGS84 projection and tiled. A UTM tiling following the US-MGRS (US-Military Grid Reference System) grid approach is proposed:

- The vertical UTM boundaries and horizontal latitudinal band boundaries define 6° X 8° Grid Zones.
- Each Grid Zone is filled by 100,000-meter grid squares.

The MGRS is derived from the UTM grid system and the UPS (Universal Polar Stereographic) grid system, but uses a different labelling convention. The MGRS is used for the entire earth.

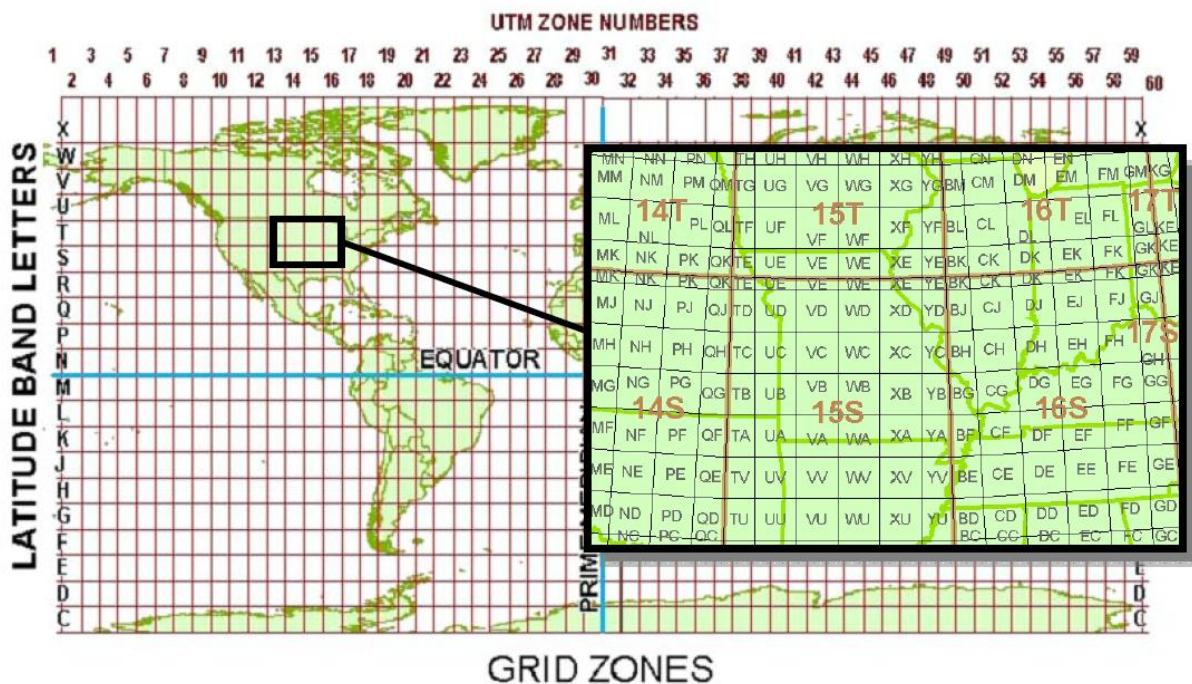

Figure 6: Example of tiling (100x100km<sup>2</sup>) within the UTM15 zone

Hence, the ortho-rectified products (Level-1C) are tiled according to this grid (approximately 100kmx100km). The UTM zone is selected according to each Tile of the product.

### 2.7.3 Granules Along-Track Aggregation

Granules Along-Track aggregation is a download option applicable to L1A and L1B User Products allowing the user to create for each detector one image grouping all single Granules along track. An image viewer may not support well the high number of Granules constituting the L1A/L1B S2 products therefore this option allows to produce at maximum 12 images per band, whatever is the Area-Of-Interest as illustrated in the following figure.



Figure 7: Granules aggregated along-track

### 2.7.4 Tile Consolidation

Due to the number of CGS in the PDGS system, a single Datatakes could be split in several Datastrip. For products in instrument geometry (L0, L1A, L1B), this does not raise any issues but for L1C and L2A, the tiles located at the end of a Datastrip and at the beginning of the consecutive one are complementary and uncompleted. Those tiles need to be consolidated to complete them as shown in the following figure:



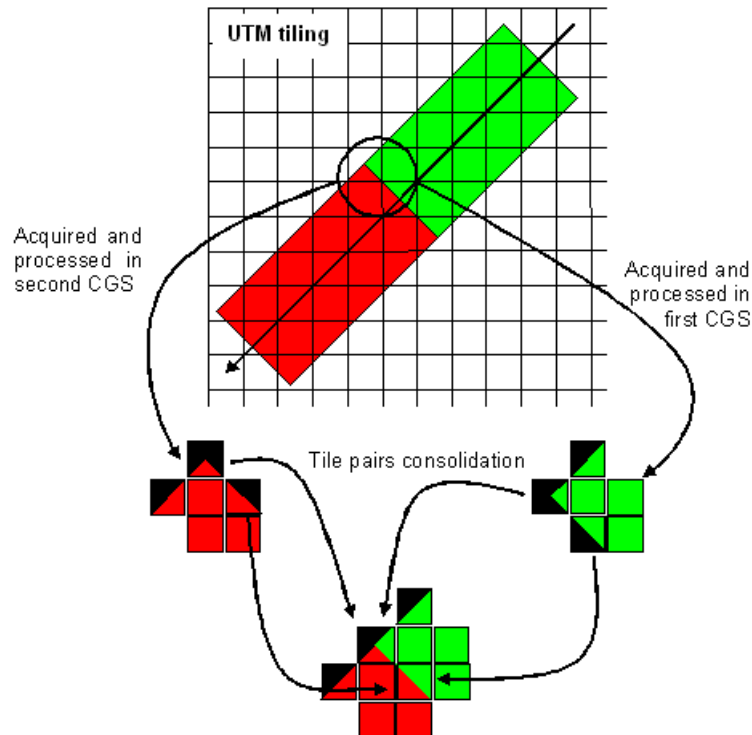

Figure 8: Tile pairs consolidation

## 2.8 Product Levels

All data acquired by the MSI from the Sentinel-2 constellation will be systematically processed from Level-0 up to Level-2A as cascading from data reception on-ground in a systematic manner.

Level-0 data processing operations will be performed in real-time during the data-reception operations. They will consist in packaging the MSI and satellite ancillary raw-data supplied by the front-end CGS equipment, and in locally archiving it as Level-0 data files together with appropriate annotations and metadata to enable further processing.

The Level-0 consolidation processing will provide the preliminary quick-look and the ancillary data to be included inside the Level-0 consolidated product.

Level-1 processing includes the three-step processing to generate Level-1A, Level-1B and Level-1C data starting from the consolidated Level-0 data. These three levels correspond respectively to the S2MSI1A, S2MSI1B and S2MSI1C data-products.

The Sentinel-2 Product Levels are:

- The **Level-0** products correspond to raw images still on board compressed.
- The **Level-1** products are generated from the Level-0 product:
  - Level-1A: "Raw Image" after decompression,

- Level-1B: "Radiometrically corrected." product with geometric model refined appended but not applied,
- Level-1C: Orthorectified product (geometric ortho-correction taking into account a DEM) providing Top Of Atmosphere Reflectances.
- Level-2A: Orthorectified product providing Bottom-Of-Atmosphere reflectances, and basic pixel classification (including classes for different types of cloud).

The following table outlines the Sentinel-2 User Products with the specification of the product type, level, a brief description and intended usership. For completeness, in addition to the Level-0, Level-1 and Level-2 MSI products, the table contains also the S2HKTM (satellite housekeeping) product.

Type	Processing Level	Outline Description	Granularity	Intended Users
S2HKTM	N/A	Sentinel-2 spacecraft Housekeeping telemetry in Transfer Frame format	One entire downlink pass (downlink dependent)	Sentinel-2 flight operations
S2MSI0	0	MSI raw-image-data (compressed) in raw ISP format	Per detector and on-board scene 25km across-track 23km along-track	MSI instrument Experts PDGS internal users
S2MSI1A	1A	MSI uncompressed raw image data with spectral bands coarsely coregistered and appended Ancillary data	Per detector and along-track onboard scene size: 25km across-track 23km along-track	Not distributed to external users
S2MSI1B	1B	Radiometrically corrected (calibrated) MSI image data with spectral bands co-registered and refined geometric model appended but not applied	Along-track band co-registration is performed	Expert End Users
S2MSI1C	1C	Ortho-rectified and UTM geo-coded Top-of- Atmosphere Reflectance with sub-pixel multispectral and multi-date registration		
S2MSI2A	2A	Ortho-rectified and UTM geo-coded Bottom-of-Atmosphere multi-spectral reflectance. Additional outputs are Aerosol Optical Thickness (AOT) map, Water Vapour (WV) map, Scene Classification map together with Quality Indicators data.	One 100x100km UTM Tile covered within one orbit	General End Users

Table 2: Sentinel-2 product levels and main characteristics

## 2.9 Processing Baseline

The Processing Baseline completely defines the processing environment baseline used at the time of the product generation in terms of:

- Processors version number;
- Static Auxiliary Data (e.g. DEM, GRI) each one with a version number;
- Dynamic Auxiliary Data (e.g. ECMWF data or POD data), each one with its associated version number,
- Processing Configuration files versions.

Processing Baseline = xx.yy where x,y = {0;9}

An increase of the Processing Baseline code is generated by a change of the elements listed above. A major change is traced by the “xx” digits, a minor change is traced by the “yy” digits.

Note: all the PDIs of a Datatake are always processed with the same Processing Baseline even if acquired in different stations.

## 2.10 Metadata

The metadata information included in the products (PDI and User Product) provides the requested level of information and referring all the product data items. In the chapter 3 and 4 all the metadata provided for each PDI (Granule and Datastrip) and User Product (L0/L1A/L1B/L1C/L2A) are detailed.

Each PDIs contains many metadata, each one being allocated a metadata level from general product information to detailed product indicators:

- **Brief** metadata provide to the user high level information and an overview of the product.
- **Standard** metadata are an extension of the previous one providing more detailed information on the delivered product. Additional information is then appended.
- **Expertise** metadata can be appended to the previous ones. Those metadata identifies a set of information accessible to expert users mainly for Cal/Val or expertise purposes e.g. for in flight commissioning or for image quality routine follow-up.

The classification Brief/Standard/Expertise is used to provide different level information to the user according to their permissions.

Each PDI metadata (cf. *S2-PDGS-TAS-DI-PSD-V14\_Schemas.zip* annexed to this document) is labelled with a specific *metadataLevel* attribute. During the User Product assembling, this attribute is used to select, according to a download option (cf. section 4.4), the set of metadata that must be included in the product.

For these filtered fields, the *metadataLevel* attribute is not written in the User Product's metadata.

The schemas related to the PDIs provided with the zip file (*S2-PDGS-TAS-DI-PSD-V14\_Schemas.zip*) annexed to this document, contains the *metadataLevel* attribute for each metadata describing the product data items.

## 2.11 Quality Indicator (QI) Data

Sentinel-2 products are annotated with Quality Indicators (QIs) in order to provide the user of a dataset the required information to assess its suitability for a certain use/application.

QIs are coming partly as result of the nominal production processing and partly from On Line Quality Control checks performed systematically after the nominal production processing.

Some examples of Quality Indicators are defective pixels mask, cloud masks, on-line quality control reports.

## 2.12 Satellite Ancillary Data

The Satellite Ancillary Data (SAD) is dumped at the end of each acquisition over a ground station. Sentinel-2 satellites provide Ancillary Data to feed the on-ground image data processing such as orbit position, velocity, time and attitude (generated by the Attitude and Orbit Control System).

The detailed content of the Satellite Ancillary Data source packets is provided in the Satellite Ancillary Data ICD (Interface Control Document) [S2GICD-SAD].

Note that the raw SAD which is a PDI itself (cf. section 3.22) cover one orbit; the decoded SAD, which is inside the product metadata, cover at most the full Datatake.

## 2.13 Auxiliary Data

Auxiliary Data identifies all auxiliary information to be used by the PDGS for the data-processing activities. The auxiliary data required by S2 data production are:

- Ground Image Processing Parameters (**GI PP**): set of **XML** files associated to each processing component to define a set of parameters and their values.

According to a download option, the GIPP files can be embedded in the User Product.

Digital Elevation Model (**DEM**): at low spatial resolution (GLOBE DEM in DTED-0 format) and at high spatial resolution (SRTM-based in DTED-1 format). Due to huge volume of this auxiliary data, the DEM is never embedded in the User Product (no download option).

- Global Reference Image (**GRI**): set of unitary reference images covering one orbit. Each unitary reference image is a mono-spectral **Level-1B product**.

Due to huge volume of this auxiliary data, the GRI data are never embedded in the User Product (no download option).

- European Centre for Medium-Range Weather Forecasts (**ECMWF**): Total Column Ozone (TCO3), Total Column Water Vapour (TCWV) and Mean Sea Level pressure (MSL) not required for data processing but appended to Level-1C User Products.

Those auxiliary data, resampled in L1C geometry and generated in GRIB V1 format (cf. [GRIB]) are always provided as part of L1C Tiles. The raw ECMWF are never embedded in the User Product (no download option).

- International Earth Rotation & Reference Systems service (**IERS**): bulletins about Earth orientation and Terrestrial reference system (Earth Pole position, UT1-UTC,) published daily. These bulletins are required for the computation of the geometrical model.

According to a download option, the IERS bulletins can be embedded in the User Product.

- Precise Orbit Determination (**POD**): an **XML** file, used in case of GPS data anomaly with the on-board navigation solution.

Auxiliary data never embedded in the User Product (no download option).

### 2.14 Browse Image Data

The Browse Image in PNG format can be included in the User Product if required by the user (download option). The Browse Image corresponding to the entire product is based on the PVI extracted from the Level-1C Tiles (cf. section 3.11.2).

### 3. PDI FORMAT DEFINITION

This chapter describes the physical structure and content provided for each PDI-Type.

#### 3.1 Type of PDI

The following type of PDIs has been identified:

- **PDI-type Granule:** *Granule PDIs* contains image data and it is defined for each processing level, Level-0 (consolidated), Level-1A, Level-1B and Level-1C.
- **PDI-type Datastrip:** *Datastrip PDIs* are defined for each processing level, Level-0 (consolidated), Level-1A, Level-1B and Level-1C.

Granule and Datastrip PDIs will be stored as a **tar**<sup>1</sup> file identified by a unique PDI\_ID (string label defined for each kind of PDI described in the next chapter).

**NOTE:** the PDI used to construct the End User Product will never be embedded as TAR but as folder containing the selected components to be included in the product.

- **PDI-type True Color Image:** TCI&PVI is always associated to a unique Level-1C product. The PDI related to the L1C product at Tile level, includes the Preview Image. For TCI (JPEG2000 with GML geo-referencing) a specific PDI is provided because can be needed to **distribute** it independently from the Level-1C Tile PDI.
- **PDI-type Auxiliary:** this type of PDI refers to each archived auxiliary data. In this case the PDI (where not otherwise specified) coincides with the aux data itself and the name of the auxiliary data represents the unique PDI\_ID identifying univocally the auxiliary data. If the PDI is composed by a unique file (the auxiliary file), the PDI coincides with the file itself, otherwise the PDI is archived as a *tar* or *tgz* file.
- **PDI-type Ancillary:** similarly to the auxiliary data, this type of PDI (where not otherwise specified) is coincident with the ancillary file itself and it is uniquely identified by its file name (PDI\_ID). If the PDI is composed by a unique file, the PDI coincides with the file itself, otherwise the PDI is archived as a *tar* file.

The following table resumes the type of PDI presented above:

PDI-type	PDI-subtype	Description
Granule	Granule Level-0	Level-0 Granule PDI.
	Granule Level-1A	Level-1A Granule PDI.
	Granule Level-1B	Level-1B Granule PDI.

<sup>1</sup>In order to avoid performance degradation of the Inventory application, the Inventory\_Metadata.xml file is always in a fixed position and then, it must be the first in the tar. In general, the TAR shall be packaged to have all ASCII files followed by binary files.

	Tile Level-1C	Level-1C Tile PDI.
Datastrip	Datastrip Level-0	Level-0 Datastrip PDI. Level-0 refers to <b>consolidated</b> Level-0 PDI containing the <b>Quick Look</b> image.
	Datastrip Level-1A	Level-1A Datastrip PDI.
	Datastrip Level-1B	Level-1B Datastrip PDI.
	Datastrip Level-1C	Level-1B Datastrip PDI.
True Color Image	TCI	TCI PDI.
Auxiliary	GRI	The <b>GRI</b> files are stored with your PDI-id and the link to these aux files is set among the metadata at Datastrip level.
	DEM	The <b>DEM</b> is stored with your PDI-id and the link to these aux files is set among the metadata at Datastrip level.
	GIPP	The <b>GIPP</b> files are stored with own PDI-id and the link to these aux files is set among the metadata at Datastrip level.
	ECMWF	Raw <b>ECMWF</b> data containing Meteorological datasets. Resampled ECMWF data are always provided within L1C Tile PDI, in L1C product geometry.
	IERS Bulletin	The International Earth Rotation and Reference System Service ( <b>IERS</b> ) provides data on Earth orientation, on the International Celestial Reference System/Frame, on the International Terrestrial Reference System/Frame, and on geophysical fluids.
	POD	Precise Orbit Determination ( <b>POD</b> ): an XML file, used in case of contingency with the on-board navigation solution.
Ancillary	HKTM	PDI relative to housekeeping telemetry data.
	SAD	The SAD PDI is formatted as a tar file including a set of binary SAD files, each one corresponding to one SAD file type and covering one orbit ANX to ANX or shorter (current dump orbit).

Table 3: Type of PDI

### 3.2 PDI Naming Convention

PDI\_ID is a logical and a physical naming convention defined to identify univocally each type of PDI. In fact, *PDI\_ID* or *PDI\_ID.tar* (where the tar compression is foreseen) represents the PDI physical name defined case by case in the document, but PDI\_ID (without extension) represents also the logical convention used to reference each type of PDI in the archive.

The PDI\_ID naming convention is described hereafter:

MMM\_CCCC\_TTTTTTTTTT\_<Instance\_id> where:

Part	Description	Comment
MMM	<b>Mission ID</b>	“S2A” or “S2B” “S2_” applicable to the constellation, used for satellite independent files.
CCCC	<b>File Class</b>	4 uppercase letters can contain digits. OPER for “Routine Operations” files.  Note that the File Class will be set “OPER” for all products generated during the operation phase. During validation or for internal testing other values can be defined.
TTTTTTTTTT	<b>File Type</b> (File Category + File Semantic)	10 uppercase letters can contain digits and underscores.
<Instance ID>	<b>Instance Id</b>	Uppercase letters, digits and underscores.

Table 4: PDI File name decomposition

**File Type** is a 10 characters field either uppercase letters, digits or underscores “\_”. The File Type field is subdivided into two sub-fields as follows:

TTTTTTTTTT = FFFFDDDDDD where:

- FFFF = File Category;
- DDDDDD = Semantic Descriptor.

**File Category** sub-field is defined as the 4 initial characters of the File Type. The File Category is composed by 3 characters and an ending underscore “\_” for separation with the Semantic Descriptor. This sub-field allows the definition of file groups characterised by related information / configuration information / generated data / usage of the data / etc.

**Semantic Descriptor** sub-field is composed by the 6 characters contiguous to the File Category sub-field. The Semantic Descriptor can be composed of uppercase letters, digits or underscores “\_”. This sub-field is unique for a given File Type and must be as descriptive as possible given the 6 character limitation to characterize the information contained by the file.

For the Granule (Tile), Datastrip and TCI PDI the following convention is used:

- File Category is set as **MSI\_** constant string.
- Semantic Descriptor is composed of **YYY\_ZZ** where:



Semantic Descriptor Sub-Field Name	Value/Meaning
YYY	<ul style="list-style-type: none"> <li>• L0_ for Level 0 products</li> <li>• L1A for Level 1A products</li> <li>• L1B for Level 1B products</li> <li>• L1C for Level 1C and TCI products</li> </ul>
ZZ	<ul style="list-style-type: none"> <li>• GR (Granule)</li> <li>• DS (Datastrip)</li> <li>• TL (Tile)</li> <li>• TC (True Color Image)</li> </ul>

The following table resumes the unique File Type for a given Granule (Tile), Datastrip and TCI PDI:

Type Of PDI	File Type (File Category + Semantic Descriptor)
Granule Level-0	MSI_L0_GR
Datastrip Level-0	MSI_L0_DS
Granule Level-1A	MSI_L1A_GR
Datastrip Level-1A	MSI_L1A_DS
Granule Level-1B	MSI_L1B_GR
Datastrip Level-1B	MSI_L1B_DS
Tile Level-1C	MSI_L1C_TL
Level-1C Tile Consolidated	MSI_L1C_CO
Datastrip Level-1C	MSI_L1C_DS
Tile Level-2A	MSI_L2A_TL
Datastrip Level-2A	MSI_L2A_DS
Level-2A Tile Consolidated	MSI_L2A_CO
True Color Image	MSI_L1C_TC

Table 5: Granule (Tile), Datastrip and TCI PDI File Type

The following tables give a list of File Type assigned to each PDI - type GIPP, DEM, GRI, HKTM and SAD data.

Regarding the GIPP files listed in the table hereafter, note that the file types not highlighted corresponding to the GIPP files listed in the Annex D. The GIPP files highlighted in blue (foreseen for each level of processing) are not real GIPP files but general configuration files managed by the processing chains as the standard GIPP files.

GIP\_OLQCPA GIPP file is detailed in the referenced document [OLQC-GIPP].

GIPP files	FileType (Category+Semantic)
AnaTm image parameters file	GIP_ATMIMA
AnaTm HK parameters file	GIP_ATMSAD
Datation parameters file	GIP_DATATI
LR Extraction parameters file	GIP_LREXTR
InitLoc Inv parameters file	GIP_INVLOC
Pixel line of sight for each bands in the focal plane reference frame	GIP_VIEDIR

<b>GI PP files</b>	<b>FileType (Category+Semantic)</b>
Platform model	GIP_SPAMOD
List of blind pixels	GIP_BLINDP
CloudInv parameter file	GIP_CLOINV
InitLoc production parameters file	GIP_PRDLOC
RadioS2 parameters file	GIP_R2PARA
SWIR detectors arrangement parameters	GIP_R2SWIR
Radiometric equalization parameters on board (dark current, on-board inter pixel calibration)	GIP_R2EOB2
Radiometric equalization parameters on ground (on-ground correction)	GIP_R2EQOG
List of defective pixels	GIP_R2DEPI
Deconvolution filter for each deconvoluted band	GIP_R2DEFI
Wavelets filters	GIP_R2WAFI
Wavelets base	GIP_R2DEBA
L2 Norm coefficients (denoising)	GIP_R2L2NC
Denoising thresholds (denoising)	GIP_R2DENT
Threshold file for deconvolution through wavelet packets	GIP_R2DECT
Maximum signal coefficients (denoising)	GIP_R2MACO
Noise model (denoising)	GIP_R2NOMO
Absolute calibration parameters	GIP_R2ABCA
Binning for 60m bands parameters (filters and undersampling)	GIP_R2BINN
Crosstalk correction	GIP_R2CRCO
GeoS2 parameters file (preProc)	GIP_G2PARA
Geometric parameter to refine	GIP_G2PARE
Earth model	GIP_EARMOD
Global geometrical parameters	GIP_GEOPAR
Description of the inter detectors overlapping area	GIP_INTDET
TilingS2 parameters file	GIP_TILPAR
ResampleS2 parameters file (preProc)	GIP_RESPAR
MaskS2 parameters file	GIP_MASPAR
Calibration parameters for the scene classification algorithm	GIP_L2ACSC
Calibration parameters for the atmospheric correction algorithm	GIP_L2ACAC
Processing Baseline parameters	GIP_PROBA2
Compression JP2K parameters file	GIP_JP2KPA
ECMWF parameters file	GIP_ECMWFP
On board decompression parameters file	GIP_DECOMP
OLQC configuration parameters file	GIP_OLQCPA
Processing Baseline parameters	GIP_PROBAS
Mapping parameters from 16 to 18 bits	GIP_CONVER

Table 6: GIPP File Type

<b>DEM files</b>	<b>FileType (Category+Semantic)</b>
GLOBE DEM Format	DEM_GLOBEF
SRTM DEM Format	DEM_SRTMFO
Geoid File Format	DEM_GEOIDF

Table 7: DEM File Type

GRI files	FileType (Category+Semantic)
Global Reference Images	AUX_GRIxxx Where xxx = Relative Orbit (001-143)

Table 8: GRI File Type

HKTM files	FileType (Category+Semantic)
House Keeping Telemetry data	PRD_HKTM__

Table 9: HKTM File Type

The type of a SAD packet depends on its Process Identifiers (PRID) and on its Structure Identifier (SID). The following table resumes the values of SAD packets possibly received.

Unit	Process ID (PRID)	Structure ID (SID)
OBC CSW AOCS	11	105, 106, 107, 108, 109, 110-120, 121-122, 123, 124-126
STR	A	105, 106
	B	
	C	
GPS	A	215, 218, 223, 224, 225-227, 229-232, 234, 235
	B	215, 218, 219, 223-227, 229-232, 234, 235
OBC CSW MSIC	09	123

Table 10: SAD packet type possible values

The first line of the following table contains the File Type of each unitary Raw SAD files; the second line indicates the File Type of the SAD PDI, that is the File Type of the tar containing several unitary Raw SAD files.

SAD files	FileType (Category+Semantic)
<p><b>SAD files inside the L0 Datastrip PDI:</b> Raw SAD files (named also Measurement Data files) containing only SAD packets matching a single packet type.</p> <p>SAD files inside the L0 Datastrip PDI (cf. section 3.6) cover at most the <b>temporal extent of the full Datatake</b>.</p> <p>The naming of those unitary raw SAD files is in the section 3.22.1</p>	<p>AUX_Sppnnn</p> <p>Where: nnn = SID, pp = PRID</p> <p>The possible value for SID and PRID parameters are in the table above.</p>
<p><b>SAD PDI:</b> SAD PDI (cf. section 3.22) consists in a single tar file containing one Raw SAD file per packet type and cover the <b>temporal extent of the full orbit</b>.</p>	AUX_SADATA

The naming of the SAD PDI (SAD PDI\_ID) is in the section 3.22.1

Table 11: SAD File Type

IERS Bulletin A	FileType (Category+Semantic)
IERS Bulletin A	AUX_UT1UTC

Table 12: IERS Bulletin File Type

POD file	FileType (Category+Semantic)
Restituted precise orbit determination data	AUX_RESORB
Predicted precise orbit determination data	AUX_PREORB

Table 13: POD File Type

ECMWF file	FileType (Category+Semantic)
ECMWF global forecast dataset	AUX_ECMWFD

Table 14: ECMWF File Type

**Instance ID** is used to define several sub-fields within the filename according to the nature of the file. For usage for the Sentinel PDGS, Instance ID is decomposed into a set of mandatory sub-fields in the prefix, complemented by optional ones in the trailing portion of the filename. The File Instance ID mandatory sub-fields are always placed on fixed positions within the filename for simple and unambiguous recognition. The mandatory part is subdivided into sub-fields as follows:

<Instance ID mandatory prefix> = ssss\_YYYYMMDDThhmmss

where:

- ssss is the Site Centre of the file originator
- YYYYMMDDThhmmss is the Creation Date

The Site Centre is a 4 characters field defined by either, uppercase letters, digits or underscore “\_”. The Creation Date is a 15 characters field defined according composed of:

- 8 characters, all digits, for the date: “YYYYMMDD”
- 1 uppercase T: “T”
- 6 characters, all digits, for the time: “hhmmss”

As per the applicable [EOFFS-PDGS], the optional part of the Instance ID allows further characterisation about the scope of every file. The optional suffix is appended to the mandatory prefix and starts with an underscore character immediately followed by a one-character field defining the specific options:

<optional-suffix> = \_lvvvvvvv...

where:

“I” is a one-character option Identifier (e.g. ‘S’, ‘O’, ‘V’, etc);

“vvvvvvvv” contains the trailing Option Value.

The following table lists all optional char ID used in this document:

Optional Suffix	Description	Template
Applicability Start: <b>_S</b>	<b>_S</b> YYYYMMDDTHHMMSS Appends the Validity Start Time	_S20130401T123000
Orbit Period: <b>_O</b>	<b>_O</b> ffffff_iiiiii - fffffff is the first Absolute Orbit Number reported in the file - iiiiii is the last Absolute Orbit Number reported in the file  Both first and last orbits shall be zero-padded with 6 overall digits.	_O123456_123457
Applicability Time Period: <b>_V</b>	<b>_V</b> yyyymmddThhmmss_YYYYMMDDTHHMMSS Appends the Validity Period Time fields (Start and Stop)	_V20091210T235134_20091210T235224
Detector ID: <b>_D</b>	<b>_D</b> xx  xx = 01,...12	_D05
Absolute Orbit Number: <b>_A</b>	<b>_A</b> ffffff ffffff is the Absolute Orbit Number	_A123456
Relative Orbit Number: <b>_R</b>	<b>_R</b> zzz zzz is the Relative Orbit Number	_R123
Tile Number: <b>_T</b>	<b>_T</b> xxxxx  xxxxx = fixed string	_T15SWC
Processing Baseline Number: <b>_N</b>	<b>_N</b> xx.yy x,y={0;9}, identifies the current processing baseline	_N01.01
Band Index ID: <b>_B</b>	<b>_B</b> xx  xx is the band number	_B8A
Completeness ID: <b>_W</b>	<b>_W</b> x  x = F for Full orbit x = P for Partial orbit	_WP
Degradation ID: <b>_L</b>	<b>_L</b> y  y = N for Nominal data y = D for Degraded data	_LN

The Instance ID optional part and the complete PDI\_ID are defined case by case through out the document.

### 3.3 PDI Hierarchy

A PDI-type Granule contains among its metadata the PDI\_ID (DATASTRIP\_ID) related to the PDI-type Datastrip linked to the Granule. This link establishes the hierarchy between Granule vs Datastrip.

Moreover, each PDI-type Datastrip contains among its metadata the Datatake\_ID and this link establishes the hierarchy between Granule/Datastrip vs Datatake.

### 3.4 Granule/Tile PDI Common Structure

Granule/Tile PDI is organized as shown in the following figure:

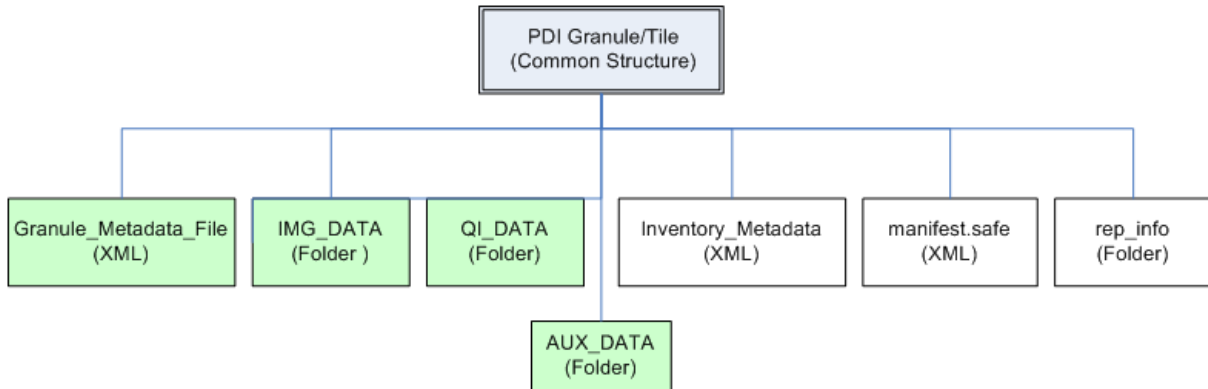

Figure 9: Granule / Tile Common Structure

1. **Granule\_Metadata\_File**: XML metadata file describing all the elements contained in the Granule PDI;
2. **IMG\_DATA**: folder containing the image data foreseen for each kind of Granule / Tile PDI;
3. **QI\_DATA**: folder containing the XML reports including the quality control checks performed by OLQC processor (for each L0/L1A/L1B/L1C/L2A PDI) and the GML quality masks (for each L1A/L1B/L1C/L2A PDI). The XSD schema of OLQC reports is provided in Annex C, the masks files are listed in the Table 3-4. In addition, in case of L1C/L2A Tile, this folder contains the PVI file.
4. **AUX\_DATA**: folder containing ECMWF dataset resampled in UTM projection. Note that this folder is provided only inside a Level-1C/Level-2A Tile PDI.
5. **Inventory\_Metadata.xml**: inventory metadata file.
6. **manifest.safe**: XML SAFE Manifest file (cf. section 3.4.4).
7. **rep\_info**: folder containing the available XSD schemas used to validate the Granule PDI components (cf. section 3.4.4)

Note that the *Inventory\_Metadata.xml*, *manifest.safe* and *rep\_info* are available inside a Granule/Tile PDI but they are removed when the PDI is included in the User Product.

### 3.4.1 Granule\_Metadata\_File Structure

The Granule\_Metadata\_File is a single metadata file containing different types of information shown in the following figure.

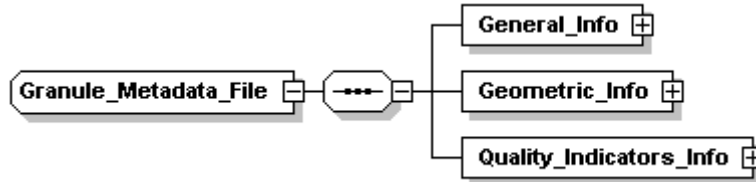

Figure 10: Granule\_Metadata\_File

The structure of the Granule\_Metadata\_File is common to all processing level (L0/L1A/L1B/L1C/L2A); the following tables summarize the Granule\_Metadata\_File content. For all details regarding the Granule metadata content, specific for each processing level (L0/L1A/L1B/L1C/L2A), refers to the dedicated section.

Info Type	Description	L0/L1A/L1B/L1C/L2A
General_Info	General information regarding Granule elements	Y
Geometric_Info	Geometric information providing the geolocation of the Granule	Y
Quality_Indicators_Info	Set of metadata providing information regarding all checks performed at Granule level for each processing level (cf. Table 3-2)	Y

Table 15: Granule / Tile Metadata Structure

Field Name	Description	L0/L1A/L1B	L1C/L2A
GRANULE_ID/TILE_ID	Unique Identifier of the Granule PDI (PDI_ID)	Y	Y
DETECTOR_ID	Detector Identifier	Y	N
DATASTRIP_ID	Unique Identifier of the Datastrip PDI (PDI_ID)	Y	Y
DOWNLINK_PRIORITY	Downlink priority flag, can be set to NOMINAL, NRT or RT	Y	Y
SENSING_TIME	Time stamp of the first line of the Granule that is the Sensing Start Time of the Granule PDI.	Y	Y



	This metadata in L1C/L2A Tile PDI is defined as the Datastrip Start time.		
Archiving_Info	Archiving centre and time	Y	Y
Processing_Specific_Parameters	Optional field reserved for production chain only (not propagated to User Product)	Y	Y

Table 16: Granule / Tile PDI General\_Info

Field Name	Description	L0	L1A/L1B	L1C/L2A
Granule_Footprint	Geolocation of the four corners of the Granule envelope (Lat, Lon, H coordinates with horizontal CRS as WGS84 and altitude given over EGM96).	Y	Y	N
Granule_Position	Position of the Granule in the Datatake.	Y	Y	N
Granule_Dimensions	Granule dimensions for each resolution band (10m, 20m and 60m).	N	Y	N
Tile_Geocoding	Coordinates of the Tile (in meters), the pixel dimensions within the Tile (in meters), the Tile size in number of lines/columns.	N	N	Y
Tile_Angles	Grid of sun and incidence angles.	N	N	Y

Table17: Granule / Tile PDI Geometric\_Info



**Sentinel-2 Products  
Specification Document**

REF : S2-PDGS-TAS-DI-PSD  
 ISSUE : 14.5  
 DATE : 14/03/2018  
 PAGE : 66 / 510

The following table summarizes the QIs provided through the Granule (Tile) metadata file. The green boxes indicate the QIs common to all processing levels.

GRANULE / TILE QUALITY INDICATORS								
Image Content Quality Indicators								
QI Type	Description	Metatada Level	Metatada Field Name	L0	L1A	L1B	L1C	L2A
Local cloud coverage indicator	Percentage of cloud coverage	Standard	CLOUDY_PIXEL_PERCENTAGE	Y	Y	Y	Y	Y
List of source packets lost / degraded within the Granule	for each couple (band, detector) with the degradation type, the error type, the date of the first line of the scene which contains the lost / degraded source packet, the counter of the first source packet in	Standard	Lost_Source_Packet_List	Y	N	N	N	N



	error and the number of lost or degraded source packet							
Local technical quality indicator	Percentage of degraded MSI and ancillary data	Standard	DEGRADED_MSI_DATA_PERCENTAGE	Y	Y	Y	Y	Y
Local no data coverage indicator	Percentage of No Data (Missing data on projected tiles) pixels	Standard	NODATA_PIXEL_PERCENTAGE	N	N	N	N	Y
Local saturated or defective coverage indicator	Percentage of saturated or defective pixels	Standard	SATURATED_DEFECTIVE_PIXEL_PERCENTAGE	N	N	N	N	Y
Local dark features coverage indicator	Percentage of pixels classified as dark features or shadows	Standard	DARK_FEATURES_PERCENTAGE	N	N	N	N	Y

Local cloud shadow coverage indicator	Percentage of pixels classified as cloud shadow	Standard	CLOUD_SHADOW_PERCENTAGE	N	N	N	N	Y
Local vegetation coverage indicator	Percentage of pixels classified as vegetation	Standard	VEGETATION_PERCENTAGE	N	N	N	N	Y
Local not vegetated coverage indicator	Percentage of pixels classified as not-vegetated	Standard	NOT_VEGETATED_PERCENTAGE	N	N	N	N	Y
Local water coverage indicator	Percentage of pixels classified as water	Standard	WATER_PERCENTAGE	N	N	N	N	Y
Local unclassified coverage indicator	Percentage of pixels classified as unclassified	Standard	UNCLASSIFIED_PERCENTAGE	N	N	N	N	Y

Local medium probability clouds coverage indicator	Percentage of pixels classified as medium probability clouds	Standard	MEDIUM_PROBA_CLOUDS_PERCENTAGE	N	N	N	N	Y
Local high probability clouds coverage indicator	Percentage of pixels classified as high probability clouds	Standard	HIGH_PROBA_CLOUDS_PERCENTAGE	N	N	N	N	Y
Local thin cirrus clouds coverage indicator	Percentage of pixels classified as thin cirrus clouds	Standard	THIN_CIRRUS_PERCENTAGE	N	N	N	N	Y
Local snow/ice coverage indicator	Percentage of pixels classified as snow or ice	Standard	SNOW_ICE_PERCENTAGE	N	N	N	N	Y
Accuracy of radiative transfer model	Declared accuracy of the radiative transfer model.	Standard	RADIATIVE_TRANSFER_ACCURACY	N	N	N	N	Y



**Sentinel-2 Products  
Specification Document**

REF : S2-PDGS-TAS-DI-PSD  
 ISSUE : 14.5  
 DATE : 14/03/2018  
 PAGE : 70 / 510

Accuracy of water vapour model	Declared accuracy of the Water Vapour model	Standard	WATER_VAPOUR_RETRIEVAL_ACCURACY	N	N	N	N	Y
Accuracy of Aerosol Optical thickness model	Declared accuracy of the Aerosol Optical Thickness model	Standard	AOT_RETRIEVAL_ACCURACY	N	N	N	N	Y

**PIXEL LEVEL QUALITY INDICATORS**

**Image Content Quality Indicators (MASK FILES)**

QI Type	Description	Metatada Level	Metatada Field Name	Main File Type	L0	L1A	L1B	L1C	L2A
Coarse cloud mask files	These vector files (derived from cloud detection using the preliminary quicklook images), contain a list of polygons in sensor geometry (Level-1A reference frame) indicating the presence of clouds on the images.	Standard	Pixel_Level_QI Pointer to the Mask files contained in the QI_DATA folder.	MSK_CLOLOW	N	Y	Y	N	N
Finer cloud mask	A finer cloud mask is computed on final Level-1C images. It is provided in the final reference frame (ground geometry).	Standard	Pixel_Level_QI Pointer to the Mask files contained in the QI_DATA folder.	MSK_CLOUDS	N	N	N	Y	Y



Technical quality mask files	These vector files contain a list of polygons in Level-1A reference frame indicating degraded quality areas in the image.	Standard	Pixel_Level_QI Pointer to the Mask files contained in the QI_DATA folder.	MSK_TECQUA	N	Y	Y	Y	Y
Detector footprint mask	A mask providing the ground footprint of each detector within a Tile.	Standard	Pixel_Level_QI Pointer to the Mask files contained in the QI_DATA folder.	MSK_DETFOO	N	N	N	Y	Y
Cloud probability map	A jp2000 image representing for each pixel the <b>cloudiness</b> probability	Standard	Pixel_Level_QI Pointer to the Mask files contained in the QI_DATA folder.	MSK_CLDPRB	N	N	N	N	Y
Snow probability map	A jp2000 image representing for each pixel the snow probability	Standard	Pixel_Level_QI Pointer to the Mask files contained in the QI_DATA folder.	MSK_SNWPRB	N	N	N	N	Y
<b>Radiometric Quality Indicators (MASK FILES)</b>									
QI Type	Description	Metatada Level	Metatada Field Name	Main File Type	L0	L1A	L1B	L1C	
Radiometric quality masks	A defective pixels' mask, containing the position of defective pixels.	Standard	Pixel_Level_QI Pointer to the Mask files contained in the QI_DATA folder.	MSK_DEFECT	N	Y	Y	Y	Y

Radiometric quality masks	A saturated pixels' mask, containing the position of the saturated pixels in the full resolution image.	Standard	Pixel_Level_QI Pointer to the Mask files contained in the QI_DATA folder.	MSK_SATURA	N	Y	Y	Y	Y
Radiometric quality masks	A nodata pixels' mask, containing the position of pixels with no data.	Standard	Pixel_Level_QI Pointer to the Mask files contained in the QI_DATA folder.	MSK_NODATA	N	Y	Y	Y	Y
Dark Dense Vegetation pixels map (optional)	A jp2000 image representing pixels classified as dark features /shadows	Standard	Pixel_Level_QI Pointer to the Mask files contained in the QI_DATA folder.	MSK_DDVPXL	N	N	N	N	Y

Table 18: Granule / Tile PDI Quality Indicators

The mask files are vector files provided as GML format files (cf. [HMA-GML]) or jpeg2000 image (for L2A Tile).  
The naming convention for the gml mask files is defined case by case in the sections 3.7.2, 3.9.2 and 3.11.2.  
The grouping strategy to have several masks in one physical GML file is described in the Annex E.



In the frame of OLQC consolidation, the quality control checks performed by OLQC processor are included inside the XML reports (cf. Annex C) stored in the QI\_DATA folder. In the following table, the quality control checks performed on the Granule metadata are provided.

**Granule Quality control Checks Information (OLQC OUTPUT)**

Check Name	Checklist Name	Description	L0	L1A	L1B	L1C	L2A
Missing_Lines	SENSOR_QUALITY	Number of missing lines	Y	Y	Y	Y	Y
Corrupted_ISP	SENSOR_QUALITY	Corrupted ISP	Y	Y	Y	Y	Y
Sensing_Time	SENSOR_QUALITY	Consistency of Sensing Time	Y	Y	Y	Y	Y
Granule_Dimensions	GEOMETRIC_QUALITY	Consistency of Granule size	N	Y	Y	Y	Y
Product_Footprint	GEOMETRIC_QUALITY	Consistency of Granule footprint wrt the expected geometry	N	Y	Y	Y	Y
Geometric_Header	GEOMETRIC_QUALITY	Consistency of the Incidence and SunAngles	N	Y	Y	Y	Y
Perc_Cloud_Coverage	GENERAL_QUALITY	Check the percentage of cloud coverage	N	Y	Y	Y	Y
List_Fake-Decompression	GENERAL_QUALITY	Check the list of fake decompressed source frames	N	Y	Y	Y	Y
Product_Syntax	FORMAT_CORRECTNESS	Check on Product components syntax & semantics correctness	Y	Y	Y	Y	Y

Table 19: Granule Quality Control Checks

### 3.4.2 Granule/Tile PDI\_ID Definition

PDI\_ID is a string label identifying univocally the archived PDI. The PDI\_ID (**tar** file name) used for a Level-0/Level-1A/Level-1B Granule PDI and for a Level-1C/Level-2A Tile PDI is compliant to [EOFFS-PDGS] and follows the description provided in the section 3.2:

PDI\_ID = MMM\_CCCC\_TTTTTTTTTT\_<Instance\_ID>.tar

The sub-strings MMM (Mission ID), CCCC (File Class), and TTTTTTTTTT (File Type) are detailed in the section 3.2.

The Granule Instance\_ID is defined hereafter.

<Instance\_Id> = <Site Centre>\_<Creation Date>\_<Sensing Time>\_<Detector ID>\_<Processing Baseline>

<Site Centre> and <Creation Date> corresponding to the Instance\_ID mandatory prefix (cf.section 3.2).

<Site Centre> (4 characters) is the centre where the PDI can be created (processing centre)

The others sub-fields are described in the following table:

Field Name	Value/Meaning	Note
<i>Sensing Time</i>	<b>S</b> YYYYMMDDTHHMMSS	This time refers to the sensing time of the first line of the PDI at Granule level in UTC time.  Fourteen digits, date and time separated by the character T.
<i>Detector ID</i>	<b>D</b> 01...12	The MSI detectors are identified by 2 digits, from 01 to 12
<i>Processing Baseline</i>	<b>N</b> xx.yy xx.yy where x,y={0;9}, identifies the current processing baseline	The Processing Baseline refers to the processing configuration baseline used at the time of the Granules generation (cf. section 2.9).  Note: all the PDIs of a Datatake are always processed with the same processing baseline even if acquired in different stations.

The Tile Instance\_ID is defined hereafter.

<Instance\_Id> = <Site Centre>\_<Creation Date>\_<Abs Orbit>\_<Tile>\_<Processing Baseline>

<Site Centre> and <Creation Date> are defined above, the others sub-fields are described in the following table:

Field Name	Value/Meaning	Note
<i>Abs orbit</i>	<b>Azzzzzz</b> zzzzzz = (000001-999999)	Absolute Orbit Number
<i>Tile</i>	<b>Txxxxx</b> Tile number where xxxxx is a fixed string of 5 characters	According to US-MGRS naming convention. See example of section 4.9.2
<i>Processing Baseline</i>	<b>Nxx.yy</b> xx.yy where x={0;9}, identifies the current processing baseline	See comment in the table above.

### 3.4.3 Granule/Tile PDI XSD Schemas

This section contains the list of the XSD schemas (annexed to the document) used to describe the physical structure and the metadata content of each Granule/Tile PDI:

1. *S2\_PDI\_Level-0\_Granule\_Structure.xsd*
2. *S2\_PDI\_Level-1A\_Granule\_Structure.xsd*
3. *S2\_PDI\_Level-1B\_Granule\_Structure.xsd*
4. *S2\_PDI\_Level-1C\_Tile\_Structure.xsd*
5. *S2\_PDI\_Level-2A\_Tile\_Structure.xsd*
  
6. *S2\_PDI\_Level-0\_Granule\_Metadata.xsd*
7. *S2\_PDI\_Level-1A\_Granule\_Metadata.xsd*
8. *S2\_PDI\_Level-1B\_Granule\_Metadata.xsd*
9. *S2\_PDI\_Level-1C\_Tile\_Metadata.xsd*
10. *S2\_PDI\_Level-2A\_Tile\_Structure.xsd*

The first set of the schemas (points 1 - 4) define the "physical organization" of the Granule/Tile PDI on the disk.

These schemas are "improperly" used to specify elements not envisaged by the XML such as folders, therefore it is actually not expected to be used for the validation of the corresponding XML file.

Oppositely, the second set of the schema (points 5 – 8) are used to validate the XML metadata file provided inside each Granule/Tile PDI.

### 3.4.4 Granule/Tile PDI SAFE Format Approach

Following the presentation in section 3.4 and the structure in the Figure 9, all SAFE Granule/Tile PDI include a **manifest.safe** file and a **rep\_info** folder according to [SAFE-SPEC].

The *manifest.safe* is an XML file formatted according to [SAFE-SPEC] providing metadata (concerning the overall context where the PDI is generated and the PDI itself) and a map of the PDI content (consisting in a reference to all data components inside the PDI including measurement data files, ancillary and auxiliary data files, XSD schema, etc).

The *manifest.safe* is composed by three main sections:

Manifest sections	Description
<b>Information Package Map</b>	Contains a high-level textual description of the product and references to all products components.
<b>Metadata Section</b>	Contains the product Metadata, including the product identification and the resource references.
<b>Data Object Section</b>	Contains references to the physical location of each component file contained in the product, with a description of the file format, location, size and checksum.

Table 20: High Level Structure of SAFE Manifest File

More in details the *manifest.safe* provided for each PDI contains:

1. metadata information defined by [SAFE-SPEC] including not only the mandatory Metadata Sections (Platform and Processing sections) but, as added value, other relevant non mandatory Metadata Sections (e.g. acquisitionPeriod, measurementOrbitReference, measurementFrameSet),
2. a sub-set of metadata redundant respect to the mandatory XML Granule\_Metadata\_File included in the PDI,
3. the map of the complete content of the PDI, namely all the references to all the files contained in the PDI (including the reference to the XML main metadata file) with the description of each file (e.g. file type, file size, coding, etc...).

Note that the Granule\_Metadata\_File file groups all metadata regarding the PDI and the mission context, while the SAFE Manifest file contains, as added value, the exhaustive map of the PDI itself and a description of each file PDI component (e.g. file type, file size, coding, etc...).

In this respect, the present document provides, for each L0/L1A/L1B/L1C Granule/Level-2A Tile PDI defined in this Section 3, the following information:

- A set of 3 tables (one for each of the three main sections), containing the list of fields (tags or attribute) to be included in the Safe Manifest file, and for each field:
  - the field name in the SAFE Manifest file (attributes names are in bold character);
  - only for the Metadata section, the corresponding field name in the Granule\_Metadata\_File schema; this column highlights the redundant sub-set of metadata included both in the XML Granule\_Metadata\_File and in the XML SAFE Manifest file;
  - a brief textual description of the field;

- the data type of the field;
  - the occurrence of the field (min/max occurrence e.g. 0..1); a minimum occurrence of 1 means that the field is mandatory.
- A practical example of SAFE Manifest file containing the tags listed in the table mentioned above. Each tag is set to an indicative value, as realistic as possible; the compliance of the SAFE Manifest file to the SAFE specification has been verified by validating the Manifest file against the SAFE XSD schemas. All SAFE Manifest files and the schemas are provided in the zip file (S2-PDGS-TAS-DI-PSD\_V14\_SAFE.zip) annexed to this document. The XSD schemas are provided as a set of *xudu.xsd* schemas located in the final leaf of the *resources* directory.

In addition to the mandatory SAFE Manifest file, according to the applicable document [SAFE-SPEC], a SAFE Granule PDI contains the *rep\_info* folder (fixed folder name recommended by [SAFE-SPEC]) including all the available schemas describing the product component files. Those schemas are not mandatory but "may be provided" inside the PDI.

The XSD schemas provided inside the *rep\_info* folder are referenced as internal product components by "metadataComponentSchemas" tag in the manifest file.

On the contrary, according to the SAFE specifications, the XSD schemas used to validate the SAFE manifest files are not included in the *rep\_info* folder but they are external to the PDI.

### 3.5 Datastrip PDI Common Structure

Datastrip PDI is organized as shown in the following figure:

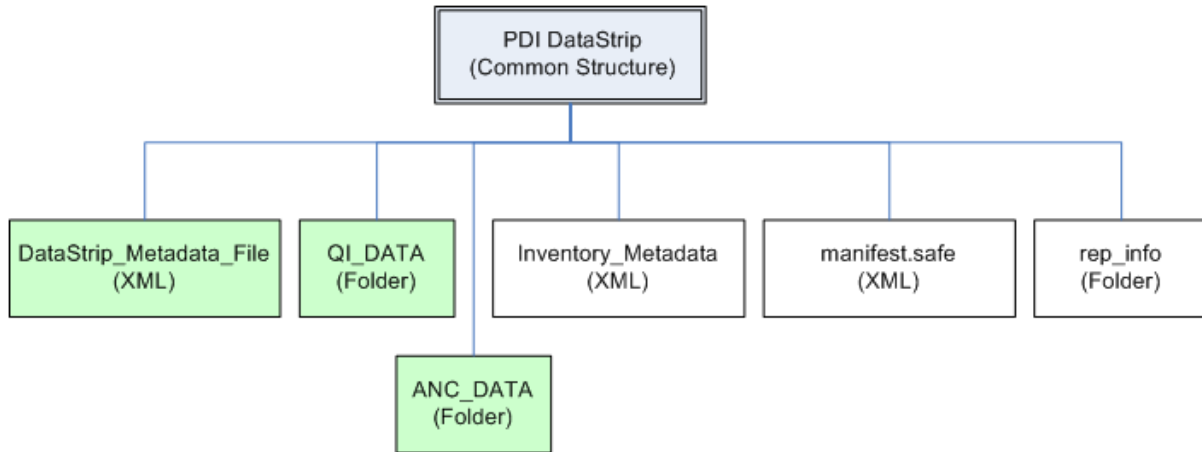

Figure 11: Datastrip Common Structure

1. **Datastrip\_Metadata\_File**: XML Metadata file describing all the elements contained in the Datastrip PDI;
2. **QI\_DATA**: folder containing the XML reports including the quality control checks performed by OLQC processor (cf. XSD schema of the OLQC report in Annex C). In addition, in case of L0 Datastrip this folder contains the preliminary QuickLook files (five image files in JPEG2000 format),
3. **ANC\_DATA**: folder containing SAD raw data as received from the DFEP. Note that this folder is provided only inside a Level-0 Datastrip PDI;
4. **Inventory\_Metadata.xml**: inventory metadata file;
5. **manifest.safe**: XML SAFE Manifest file (cf. section 3.5.4);
6. **rep\_info**: folder containing the available XSD schemas that describe each Datastrip PDI components (cf. section 3.5.4).

Note that the *ANC\_DATA*, *Inventory\_Metadata.xml*, *manifest.safe* and *rep\_info* are available inside a Datastrip PDI but they are removed when the PDI is included in the User Product.

### 3.5.1 Datastrip\_Metadata\_File Structure

The Datastrip\_Metadata\_File is a single metadata file containing different types of information shown in the following figure.

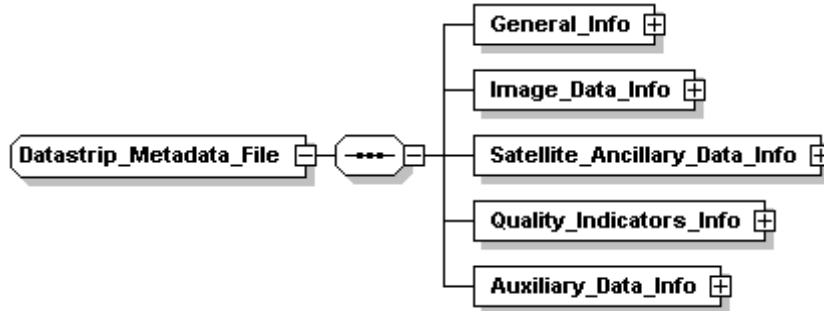

Figure 12: Datastrip\_Metadata\_File

The structure of the Datastrip\_Metadata\_File is common to all processing level (L0/L1A/L1B/L1C/L2A); the following tables summarize the Datastrip\_Metadata\_File content and specify the applicability to the processing level. For all details regarding the Datastrip metadata content, specific for each processing level (L0/L1A/L1B/L1C/L2A), refers to the dedicated section in this chapter.

Info Type	Description	L0/L1A/L1B/L1C/L2A
General_Info	General information characterizing the Product Data Item	Y
Image_Data_Info	Image data information from MSI telemetry	Y
Satellite_Ancillary_Data_Info	Ancillary data information from Satellite Ancillary Telemetry	Y
Quality_Indicators_Info	Results of all quality checks performed at Datastrip level.	Y
Auxiliary_Data_Info	Auxiliary data information	Y

Table 21: Datastrip Metadata Structure



Field Name	Description	L0/L1A/L1B/L1C/L2A
Datatake_Info	Identification of the source Datastrip acquisition. General information.	Y
Processing_Info	Datastrip production information	Y
Datastrip_Time_Info	Datastrip Sensing Time information	Y
Downlink_Info	S2 data downlink information	Y
Archiving_Info	S2 data archiving information	Y
Processing_Specific_Parameters	Optional field reserved for production chain only (not propagated to User Product)	Y

Table 22: Datastrip PDI General\_Info

Field Name	Description	L0	L1A	L1B	L1C	L2A
Granules_Information	List of Granules composing the whole Datastrip.	Y	Y	Y	N	N
Tiles_Information	List of the tiles composing the whole Datastrip.	N	N	N	Y	Y
Sensor_Configuration	MSI Sensor configuration (Information from MSI telemetry)	Y	Y	Y	Y	Y
Geometric_Header_List	Geometric information	Y	Y	Y	N	N
Radiometric_Info	Radiometric Information	N	Y	Y	Y	Y
List_Fake_Decompr_Source_Frames	List of the decompressed source frames	N	Y	N	N	N
Geometric_Info	Refined model information	N	N	Y	Y	Y

Table 23: Datastrip PDI Image\_Data\_Info

The Satellite Ancillary Data information, available through the Datastrip metadata file, is retrieved from SAD raw data stored in archive with a specific filename defined in the section § 3.22.1.

Field Name	Description	L0/L1A/L1B/L1C/L2A
Time_Correlation_Data_List	Time Correlation Data (sampled at 1Hz)	Y
Ephemeris	Description of ephemeris data (filtered and raw)	Y
Attitudes	Description of attitudes data (filtered and raw)	Y

Thermal_Data	Thermal data acquired at 1 Hz	Y
Lost_Source_Packet_List	List of source packets lost/degraded	Y
ANC_DATA_REF	<p>Reference to folder including the SAD raw data used for the processing. The SAD raw Data are provided only inside the L0 Datastrip PDI. This metadata is not mandatory for L1 Datastrip PDI.</p> <p>Note:          Since the ANC_DATA folder inside the L0 Datastrip PDI is removed during the L0 User Product generation (section 4.6.7.3) the metadata ANC_DATA_REF inside the L0 User Product (defined at Datastrip level) refers to the mandatory folder ANC_DATA contained in the L0 User Product.</p>	Y

Table 24: Datastrip PDI Satellite\_Ancillary\_Data\_Info



**Sentinel-2 Products  
Specification Document**

REF : S2-PDGS-TAS-DI-PSD  
ISSUE : 14.5  
DATE : 14/03/2018  
PAGE : 83 / 510

The following table summarizes the QIs provided through the Datastrip metadata file.

DATASTRIP QUALITY INDICATORS							
Geometric Quality Indicators							
QI Type	Description	Metatada Field Name	L0	L1A	L1B	L1C	L2A
Absolute location assessment	Absolute location performance for the Datastrip given from a GIPP table, depending on the health status of the GPS and AOCS sensors (gyros and startrackers) provided in the Satellite Ancillary Data.	Absolute_Location	Y	Y	Y	Y	Y
Planimetric stability assessment	A planimetric stability performance for the Datastrip given from a GIPP table, depending on the health status of the GPS and AOCS sensors (gyros and startrackers) provided in the Satellite Ancillary Data.	Planimetric_Stability	Y	Y	Y	Y	Y
Ephemeris data quality	Ephemeris data quality retrieved from GPS Dilution of precision (DOP) information.	EPHEMERIS_QUALITY	Y	Y	Y	Y	Y
Ancillary data quality	Ancillary data quality retrieved from GPS Dilution of precision (DOP) information.	ANCILLARY_QUALITY	Y	Y	Y	Y	Y
Geometric refining quality	Available by Datastrip and only if geometric refining applied	Geometric_Refining_Quality	N	N	Y	Y	Y
Multi-spectral registration performance assessment	3 values for 10, 20 and 60m bands (from GIPP data)	Multi_Spectral_Registration	N	N	Y	Y	Y
Quicklook Info							
QI Type	Description	Metatada Field Name	L0	L1A	L1B	L1C	L2A
Quicklook information	Preliminary quicklook data provided for each Datastrip composing the product	Preliminary_QuickLook	Y	N	N	N	N
Radiometric Quality Indicators							
QI Type	Description	Metatada Field Name	L0	L1A	L1B	L1C	L2A



Radiometric quality indicators for each band (from GIPP data)	Alpha and Beta parameters providing the instrument noise as a function of the radiometric count X for Level-1B: Noise= square root (Alpha_X + Beta_X* X)	Noise_Model	N	Y	Y	Y	Y
Radiometric quality indicators for each band (from GIPP data)	Absolute calibration accuracy provided as a percentage of accuracy	ABSOLUTE_CALIBRATION_ACCURACY	N	Y	Y	Y	Y
Radiometric quality indicators for each band (from GIPP data)	Cross-band calibration accuracy provided as a percentage of accuracy	CROSS_BAND_CALIBRATION_ACCURACY	N	Y	Y	Y	Y
Radiometric quality indicators for each band (from GIPP data)	Multi-temporal calibration accuracy provided as a percentage of accuracy	MULTI_TEMPORAL_CALIBRATION_ACCURACY	N	Y	Y	Y	Y

Table 25: Datastrip PDI Quality Indicators

In the frame of OLQC consolidation, the quality control checks performed by OLQC processor are included inside the XML reports (cf. Annex C) stored in the QI\_DATA folder. In the following table, the quality control checks performed on the Datastrip metadata are provided.

Datastrip Quality control Checks Information (OLQC OUTPUT)							
Check Name	Checklist Name	Description	L0	L1A	L1B	L1C	L2A
Degraded_SAD	SENSOR_QUALITY	Check on the consistency of satellite ancillary data	Y	Y	Y	Y	Y
Datation_Model	SENSOR_QUALITY	Check the correctness of the Datation Model	Y	Y	Y	Y	Y
Relative_Orbit_Number	GENERAL_QUALITY	Check the consistency of the relative orbit number	Y	Y	Y	Y	Y
Attitude_Quality_Indicator	GEOMETRIC_QUALITY	Check the admissibility of The Attitude Quality Indicator (QI)	Y	Y	Y	Y	Y
Processor_Version	GENERAL_QUALITY	Check the consistency of the processor version	N	Y	Y	Y	Y



**Sentinel-2 Products  
Specification Document**

REF : S2-PDGS-TAS-DI-PSD  
 ISSUE : 14.5  
 DATE : 14/03/2018  
 PAGE : 85 / 510

Ephemeris_Planimetric_Stability	GEOMETRIC_QUALITY	Check the consistency of the Ephemeris and Planimetric Stability	N	Y	Y	Y	Y
Absolute_Location_Value	GEOMETRIC_QUALITY	Check the consistency of the Absolute Location	N	Y	Y	Y	Y
Geometric_Refining	GEOMETRIC_QUALITY	Check the correctness of the Geometric Refining process results	N	N	Y	Y	Y
Radiometric_Quality_Indicators	RADIOMETRIC_QUALITY	Check the Radiometric Quality Indicators	N	N	Y	Y	Y
Tile_position	GEOMETRIC_QUALITY	Check on the consistency of the product boundaries (ground coordinates)	N	N	N	Y	Y
Product_Syntax	FORMAT_CORRECTNESS	Check on Product components syntax & semantics correctness	Y	Y	Y	Y	Y
DS_Consistency	FORMAT_CORRECTNESS	Check on Datastrip consistency	Y	Y	Y	Y	Y

Table 26: Datastrip Quality Control Checks



Field Name	Description	L0	L1A	L1B	L1C	L2A
IERS_Bulletin	IERS bulletin. These data are provided for the start acquisition date.	Y	Y	Y	Y	Y
GIPP_List	Reference to the GIPP used: DEM, etc.	Y	Y	Y	Y	Y
PRODUCTION_DEM_TYPE	DEM type used by the production process (GLOBE or SRTM for example)	Y	Y	Y	N	N
REFERENCE_BAND	Used Reference Band	Y	Y	Y	N	N

Table 27: Datastrip PDI Auxiliary\_Data\_Info

### 3.5.2 Datastrip PDI\_ID Definition

The Datastrip PDI\_ID used to identify a Level-0/Level-1A/Level-1B/Level-1C/Level-2A Datastrip PDI follows the same convention described in the section 3.4.2 except for the sub-filed “Detector ID” which is not relevant in case of a Datastrip PDI.

In this case the optional suffix <Sensing Time> refers to start time of the first Granule of the Datastrip.

### 3.5.3 Datastrip PDI XSD Schemas

This section contains the list of the XSD schemas (annexed to the document) used to describe the structure and the metadata content of each Granule/Tile PDI:

1. *S2\_PDI\_Level-0\_Datastrip\_Structure.xsd*
2. *S2\_PDI\_Level-1A\_Datastrip\_Structure.xsd*
3. *S2\_PDI\_Level-1B\_Datastrip\_Structure.xsd*
4. *S2\_PDI\_Level-1C\_Datastrip\_Structure.xsd*
5. *S2\_PDI\_Level-2A\_Datastrip\_Structure.xsd*
  
6. *S2\_PDI\_Level-0\_Datastrip\_Metadatas.xsd*
7. *S2\_PDI\_Level-1A\_Datastrip\_Metadatas.xsd*
8. *S2\_PDI\_Level-1B\_Datastrip\_Metadatas.xsd*
9. *S2\_PDI\_Level-1C\_Datastrip\_Metadatas.xsd*
10. *S2\_PDI\_Level-2A\_Datastrip\_Metadatas.xsd*

The first set of the schemas (points 1 - 4) define the "physical organization" of the Datastrip PDI on the disk.

These schemas are "improperly" used to specify elements not envisaged by the XML such as folders, therefore it is actually not expected to be used for the validation of the corresponding XML file.

Oppositely, the second set of the schema (points 5 – 8) are used to validate the XML metadata file inside each Datastrip PDI.



#### 3.5.4 Datastrip PDI SAFE Format Approach

The SAFE Datastrip PDI definition is the same one described for the Granule/Tile PDI in the section 3.4.4.

### 3.5.5 Level-0 Granule PDI definition

Level-0 Granule PDI is defined as a **tar** file with the following structure:

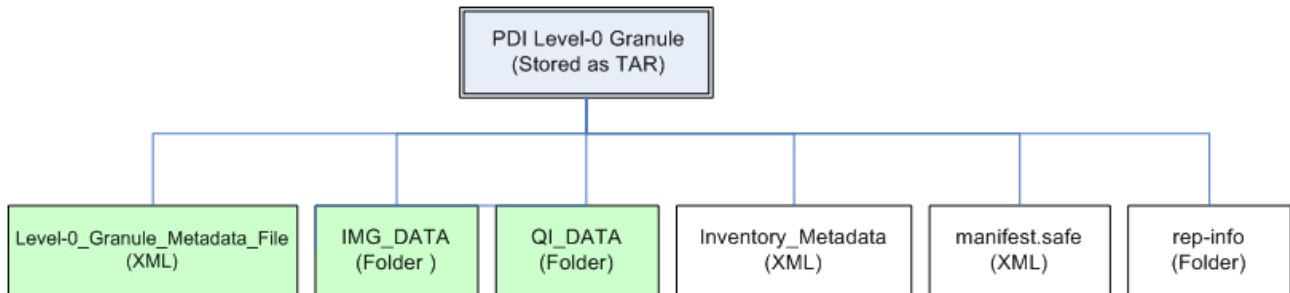

Figure 13: PDI Level-0 Granule Structure

The PDI Level-0 Granule consists of:

1. **Level-0\_Granule\_Metadata\_File**: XML metadata file containing the requested level of information and referring all the product elements composing the Granule;
2. **IMG\_DATA**: folder containing the mission data corresponding to one on-board scene for one detector and all spectral bands. The image data are provided as a set of 13 binary files, one for each spectral band, including all corresponding Image Source Packets (ISP) in the observation chronological sequence. The ISPs include their corresponding source packet annotations as a pre-pended header of each source packet;
3. **QI\_DATA**: folder containing XML reports about Geometric quality, Image content quality, Quality control checks information;
4. **Inventory\_Metadata.xml**: file containing the metadata needed to inventory the PDI;
5. **manifest.safe**: XML SAFE Manifest file (mandatory, cf. section 3.4.4);
6. **rep\_info**: folder containing the available XSD schemas that validate the PDI components (recommended by [SAFE-SPEC], cf. section 3.4.4).

### 3.5.6 PDI\_ID definition

The PDI\_ID (Granule ID) used to identify a Level-0 Granule PDI, follows the description provided in the section 3.4.2. File\_Type is defined in the section 3.2, Table 5.

Level-0 Granule file template name (Granule ID):

*S2A\_OPER\_MSI\_LO\_\_GR\_MTI\_\_20141104T134012\_S20141104T134012\_D01\_N01.12.tar*

Note that the PDI\_ID.tar is the physical name of the Granule PDI after the tar compression.

### 3.5.7 Level-0 Granule Physical Format

The PDI ID defined above represents the “Granule directory” name. Inside the Granule directory, there are the Granule components as in the Figure 13.

Inside that directory, the naming convention used to identify each real file follows the same convention used to define the Granule ID but without the Processing Baseline sub-string.

- **Level-0 Granule Metadata File (XML file):**

Granule Metadata File Template name:

*S2A\_OPER\_MTD\_L0\_\_GR\_MTI\_\_20141104T134012\_S20141104T134012\_D01.xml*

The XSD schema, which regulates the metadata file, is *PDI\_Level-0\_Granule\_Metadata.xsd* included in the *S2-PDGS-TAS-DI-PSD-V14\_Schemas.zip* file annexed to the document.

- **IMG\_DATA (folder):**

Each file contained in the IMG\_DATA folder (13 files, one image file per band) follows the naming convention defined hereafter:

Image File naming convention = <PDI\_ID\*>\_<Band\_Index>.bin where:

Field Name	Value/Meaning	Note
<i>PDI_ID*</i>	PDI_ID without Processing Baseline sub-string	
<i>Band Index</i>	Bxx where: xx = 01, 02, 03, 04, 05, 06, 07, 08, 8A, 09, 10, 11, 12	Field used to identify the spectral bands within the Granule.

IMG\_DATA/Level-L0 image file template name (binary file):

*S2A\_OPER\_MSI\_L0\_\_GR\_MTI\_\_20141104T134012\_S20141104T134012\_D01\_B03.bin*

- **QI\_DATA (folder):**

QI\_DATA folder contains the XML reports generated by On-Line Quality Control processor, including Quality Control Checks results. The *OLQC\_Report.xsd* schema and the reports naming convention are in the Annex C of the document.

File Template Name:

*S2A\_OPER\_MSI\_L0\_\_GR\_MTI\_\_20141104T134012\_S20141104T134012\_D01\_SENSOR\_QUALITY\_report.xml*

- **Inventory\_Metadata (XML file):**

XML Inventory metadata file with fixed name *Inventory\_Metadata.xml*

- **manifest.safe (XML file):**

XML file with fixed name *manifest.safe*

- **rep\_info (folder):**

Folder containing the following XSD schemas:

1. *S2\_PDI\_Level-0\_Granule\_Metadata.xsd*
2. *Inventory\_Metadata.xsd*
3. *OLQC\_Report.xsd*

Level-0 Granule Physical Format template:

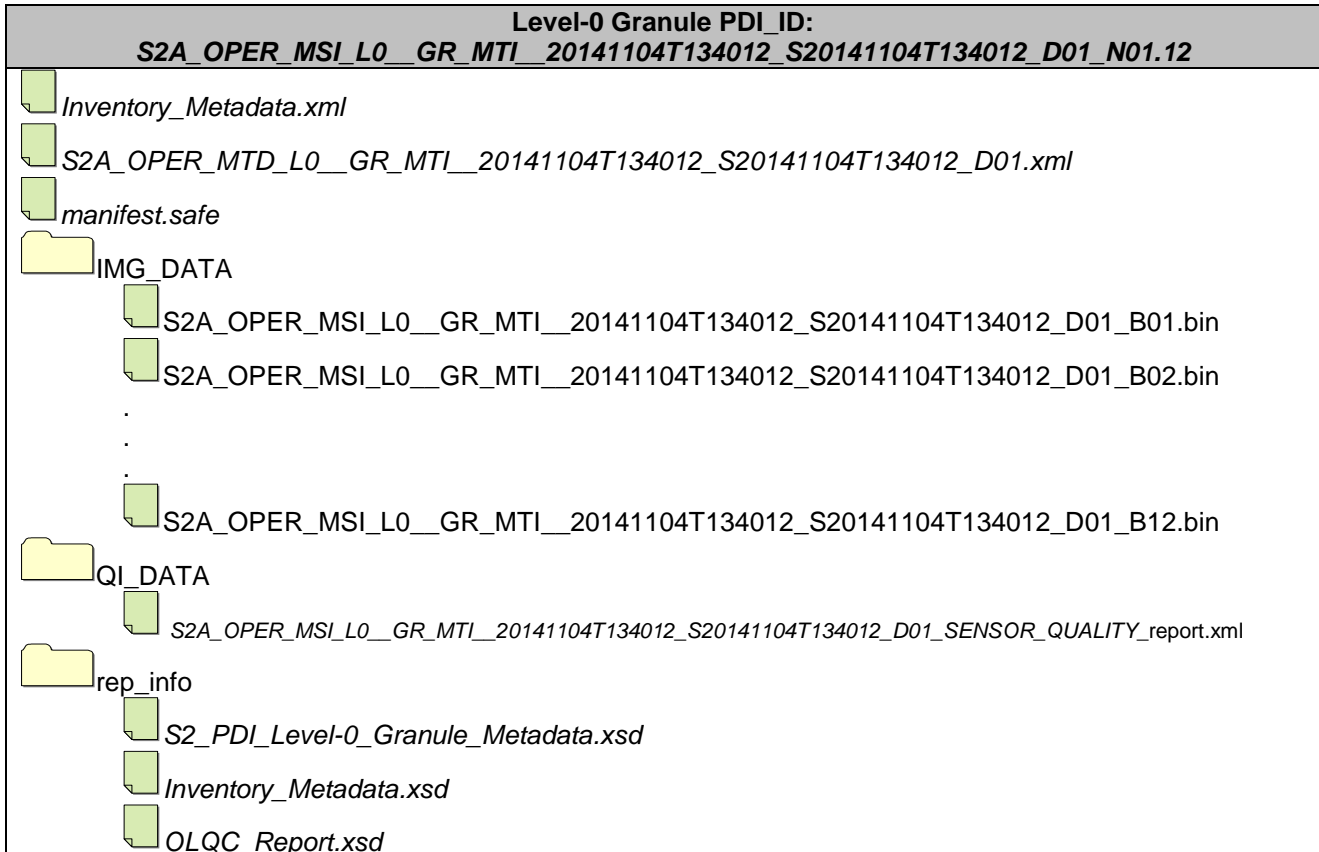

Figure 14: PDI Level-0 Granule Physical Format

### 3.5.8 Level-0 Granule PDI Structure

The *S2\_PDI\_Level-0\_Granule\_Structure.xsd* schema annexed to the document and shown in the following diagram, represents the organization of a Level-0 Granule PDI on disk. This schema is provided for information only as it is actually not expected to be used for the validation of a XML file. The diagram reflects exactly the Figure 13.

<p>diagram</p>	<p align="right">Generated by XMLSpy <a href="http://www.altova.com">www.altova.com</a></p>
<p>children</p>	<p><a href="#">Level-0_Granule_Metadata_File</a> <a href="#">IMG_DATA</a> <a href="#">QI_DATA</a> <a href="#">Inventory_Metadata</a> <a href="#">manifest.safe</a> <a href="#">rep_info</a></p>
<p>annotation</p>	<p>The Level-0 Granule is defined as a folder containing:</p> <ol style="list-style-type: none"> <li><b>Level-0_Granule_Metadata_File</b>: XML Main Metadata File.</li> <li><b>IMG_DATA</b>: folder containing the 13 image data files, one per band and per detector</li> <li><b>QI_DATA</b>: folder containing XML reports including Quality Indicators</li> <li><b>Inventory_Metadata</b>: XML inventory metadata file</li> <li><b>manifest.safe</b>: XML SAFE Manifest file</li> <li><b>rep_info</b>: folder containing the XSD schemas provided inside a SAFE Level-0 Granule</li> </ol> <p><u>Note that the Inventory_Metadata.xml, manifest.safe and rep_info are removed when the PDI is included in the User Product.</u></p>

### 3.5.8.1 Level-0\_Granule\_Metadata\_File Schema

Level-0\_Granule\_Metadata\_File is the XML metadata file provided inside each Level-0 Granule. The schema used to validate it is *S2\_PDI\_Level-0\_Granule\_Metadata.xsd* annexed to this document. A detailed description of the schema is given here but for specific details regarding each metadata (e.g. type, default value, fixed value, enumerations, occurrences, etc...) refers to the XSD file.

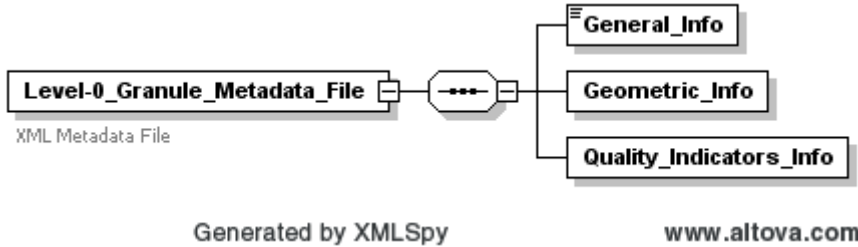
diagram	 <p align="center">Generated by XMLSpy <span style="float:right">www.altova.com</span></p>
children	<a href="#">General_Info</a> <a href="#">Geometric_Info</a> <a href="#">Quality_Indicators_Info</a>
annotation	<p>The Level-0_Granule_Metadata_File is an XML file containing three groups of metadata describing the whole product data item.</p> <ol style="list-style-type: none"> <li>1. <b>General_Info</b>: this group of metadata provides general information regarding the Level-0 Granule. The meaning for each metadata is shown in the following diagrams.</li> <li>2. <b>Geometric_Info</b>: these metadata provide information describing the geolocation of the Granule.</li> <li>3. <b>Quality_Indicators_Info</b>: these metadata provide information about cloud coverage assessment and technical quality assessment.</li> </ol>

The following figures and tables give a complete overview of the Level-0\_Granule\_Metadata\_File schema according the description provided in the section 3.4.1.

General Info:

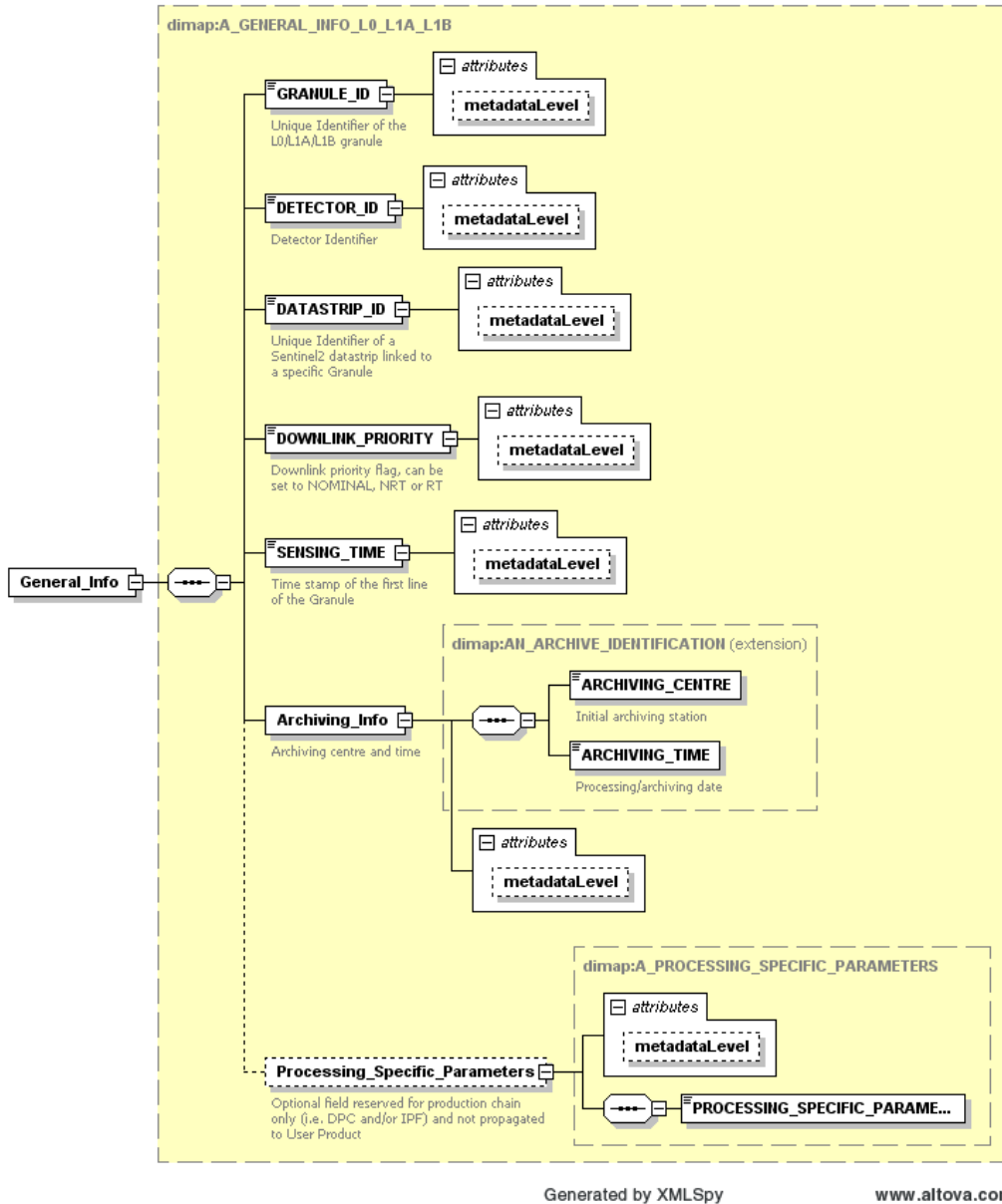

Figure 15 : Level-0\_Granule\_Metadata\_File - General\_Info Diagram



In the following tables, the third column provides the metadata level attribute for each metadata (cf. section 2.10).

General_Info		
Field Name	Description	Metatada Level
GRANULE_ID	Granule_Identifier metadata indicates the unique identifier of the Level-0 Granule. This parameter coincides with PDI_ID definition described in section 3.5.6 and univocally points a Granule PDI in the archive.	Brief
DETECTOR_ID	Detector identifier corresponding to the Granule	Brief
DATASTRIP_ID	Unique identifier of the L0 Datastrip PDI linked to L0 Granule PDI. This parameter coincides with the PDI_ID of the PDI Datastrp linked to the Granule. This link establishes the hierarchy Granule vs Datastrip (cf. section 3.3)	Brief
DOWNLINK_PRIORITY	Downlink priority flag. It can be set Nominal/NRT/RT	Standard
SENSING_TIME	Time stamp of the first line of the Granule, that is the Sensing Start Time of the Granule PDI	Standard
Archiving_Info/ARCHIVING_CENTRE	The starting point of the circulation data. The allowed values are: <ul style="list-style-type: none"> <li>• SGS_</li> <li>• MPS_</li> <li>• MTI_</li> <li>• EPA_</li> <li>• UPA_</li> <li>• CDAM</li> <li>• MPC_</li> </ul>	Expertise
Archiving_Info/ARCHIVING_TIME	Processing/archiving date (UTC data time)	Expertise
Processing_Specific_Parameters/PROCESSING_SPECIFIC_PARAMETERS	Optional field reserved for production chain only (NOT propagated to User Product)	Expertise

Table 28: Level-0\_Granule\_Metadata\_File - General\_Info Description

Geometric Info:

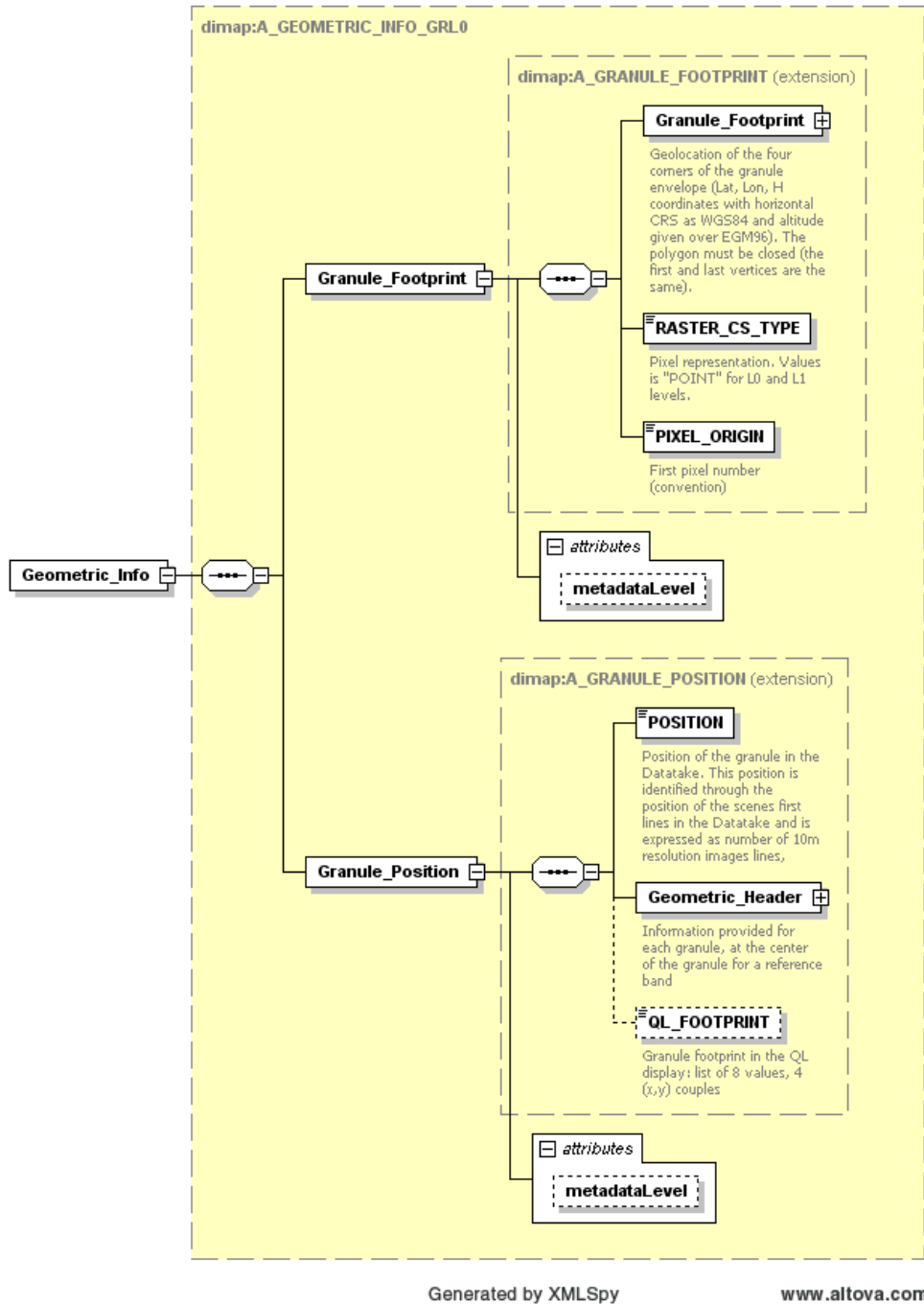

Figure 16: Level-0\_Granule\_Metadata\_File - Geometric\_Info Diagram



**Sentinel-2 Products  
Specification Document**

REF : S2-PDGS-TAS-DI-PSD  
 ISSUE : 14.5  
 DATE : 14/03/2018  
 PAGE : 99 / 510

Geometric_Info/Granule_Footprint		
Field Name	Description	Metatada Level
Granule_Footprint/Footprint/EXT_POS_LIST	Geolocation of the four corners of the Granule envelope (Lat, Lon, H coordinates with horizontal CRS as WGS84 and altitude given over EGM96).  Note: the polygon is defined as five points given counter-clockwise oriented with the first and last vertices identical.	Brief
Granule_Footprint/Footprint/INT_POS_LIST		Brief
RASTER_CS_TYPE	Pixel representation. Value is "POINT" for L0 and L1 levels.	Brief
PIXEL_ORIGIN	First pixel number (convention)	Brief
Geometric_Info/Granule_Position		
Field Name	Description	Metatada Level
POSITION	Granule_Position describes the position of the Granule in the origin Datatake. This position is identified through the position of the scenes first lines in the Datatake and is expressed as number of 10m resolution images lines). Moreover information for a reference band at the centre of the Granule (incidence angles and solar angles) are provided.	Standard
Geometric_Header/GROUND_CENTER	Information provided for a reference band, at the centre of the Granule, for each Granule. Geolocation of the Granule centre (Lat, Lon, H) Altitude is provided over the geoid.	Standard
Geometric_Header/QL_CENTER	The Granule centre in the QL display: 1 (r,c) point.	Standard
Geometric_Header/Incidence_Angles/ZENITH_ANGLE	Information provided for a reference band, at the centre of the Granule, for each Granule. Incidence angles corresponding to the centre of the Granule.	Standard
Geometric_Header/Incidence_Angles/AZIMUTH_ANGLE	Information provided for a reference band, at	Standard



	the centre of the Granule, for each Granule. Incidence angles corresponding to the centre of the Granule.	
Geometric_Header/Solar_Angles/ZENITH_ANGLE	Information provided for a reference band, at the centre of the Granule, for each Granule. Solar angles corresponding to the centre of the Granule.	Standard
Geometric_Header/Solar_Angles/AZIMUTH_ANGLE	Information provided for a reference band, at the centre of the Granule, for each Granule. Solar angles corresponding to the centre of the Granule.	Standard
QL_FOOTPRINT	Granule footprint in the QL display: list of 8 values, 4 (x,y) couples.  Note: Metadata mandatory for L0c Granule.	Standard

Table 29: Level-0\_Granule\_Metadata\_File - Geometric\_Info Description

## Quality Indicators Info:

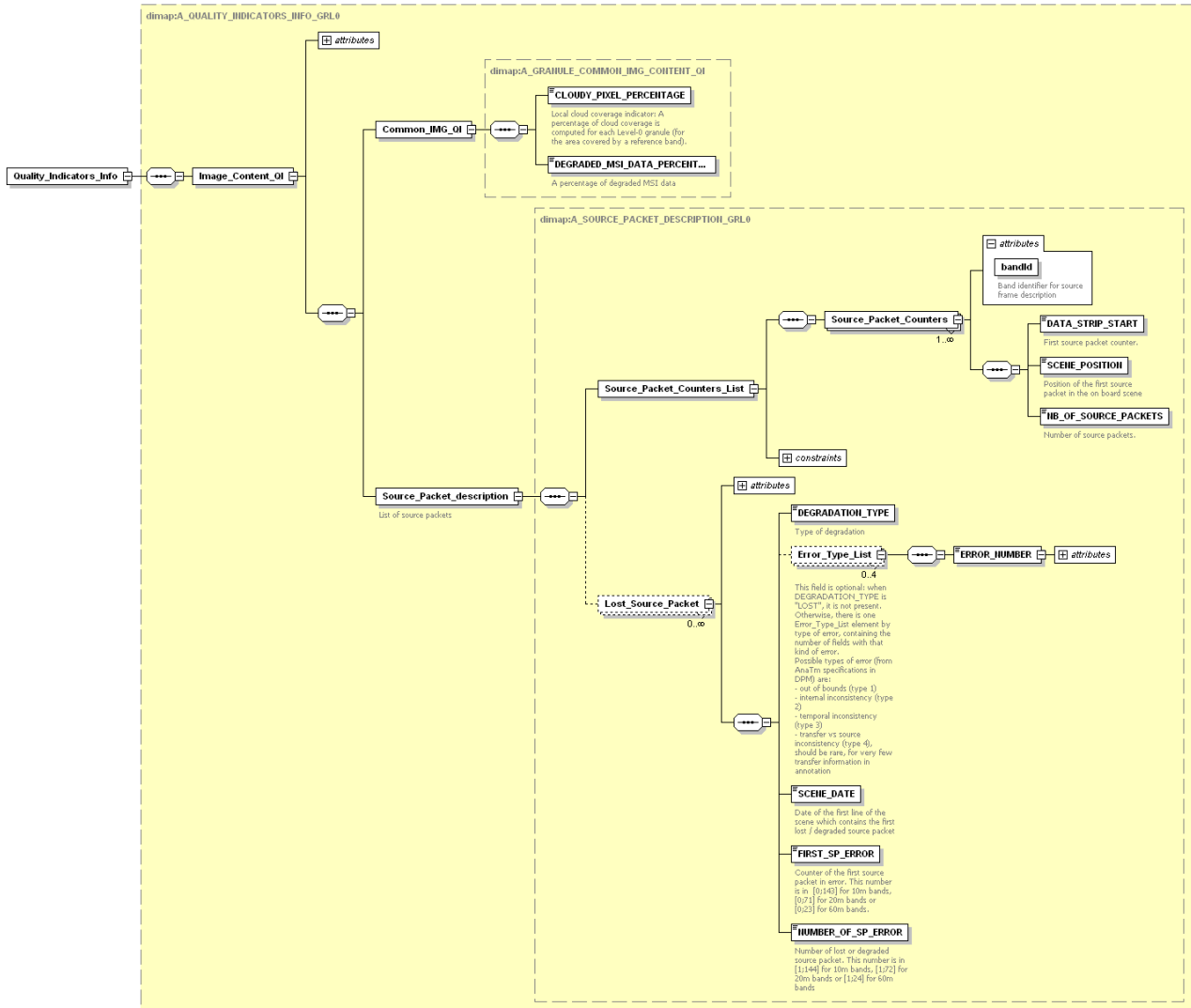

Generated by XMLSpy

www.altova.com

Figure 17: Level-0\_Granule\_Metadata\_File - Quality\_Indicators\_Info Diagram



**Sentinel-2 Products  
Specification Document**

REF : S2-PDGS-TAS-DI-PSD  
ISSUE : 14.5  
DATE : 14/03/2018  
PAGE : 102 / 510

Quality_Indicators_Info/Image_Content_QI		
Field Name	Description	Metatada Level
CLOUDY_PIXEL_PERCENTAGE	Local cloud coverage indicator: A percentage of cloud coverage is computed for each Level-0 Granule (for the area covered by a <b>reference band</b> ).	Standard
DEGRADED_MSI_DATA_PERCENTAGE	Local technical quality indicator: A percentage of degraded MSI data is provided for each Level-0 Granule.	Standard
Quality_Indicators_Info/Source_Packet_Description		
Field Name	Description	Metatada Level
Source_Packet_Counters_List/DATA_STRIP_START	First source packet counter	Standard
Source_Packet_Counters_List/SCENE_POSITION	Position of the first source packet in the on board scene	Standard
Source_Packet_Counters_List/NB_OF_SOURCE_PACKETS	Number of source packets	Standard
Lost_Source_Packet/DEGRADATION_TYPE	Type of degradation	Standard
Lost_Source_Packet/Error_Type_List/ERROR_NUMBER	Type of error (from AnaTm specifications)  Attribute: errorType	Standard
Lost_Source_Packet/SCENE_DATE	Date of the first line of the scene which contains the first lost / degraded source packet	Standard
Lost_Source_Packet/FIRST_SP_ERROR	Counter of the first source packet in error. This number is in [0;143] for 10m bands, [0;71] for 20m bands or [0;23] for 60m bands.	Standard
Lost_Source_Packet/NUMBER_OF_SP_ERROR	Number of lost or degraded source packet. This number is in [1;144] for 10m bands, [1;72] for 20m bands or [1;24] for 60m bands	Standard

Table 30: Level-0 Granule - Quality\_Indicators\_Info Description

Note that, according to OLQC procedures consolidation, the results of all quality control checks performed by OLQC processor on Level-0 Granule are included in the XML reports stored in the QI\_DATA folder (cf. § 3.4.1, Table 19).

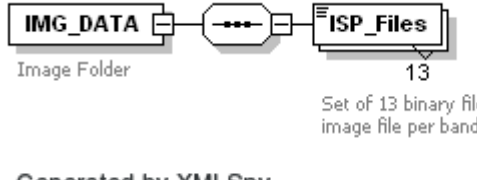

### 3.5.8.2 IMG\_DATA

diagram	 <p>Generated by XMLSpy <span style="float:right">www.altova.com</span></p>
children	<a href="#">ISP_Files</a>
annotation	<p>IMG_DATA folder contains the mission data corresponding to one on-board scene for one detector and all spectral bands. The image data are provided as a set of 13 binary files, one for each spectral band, including all corresponding Image Source Packets (ISP) in the observation chronological sequence. The ISPs include their corresponding source packet annotations as a pre-pended header of each source packet.</p> <p>Note the following clarification: The ISPs include their corresponding source packet binary annotations as a pre-pended header of each source packet. A source packet header consists in:</p> <ul style="list-style-type: none"> <li>• an annotation computed during the L0 process (called DPC annotation). This annotation is 2 bytes long. It contains the following information: <ul style="list-style-type: none"> <li>- the first bit indicates the global status of the ISP: should it be used (0) or not (1);</li> <li>- the second bit indicates if the packet is complete (0) or not (1);</li> <li>- the third bit indicates the packet integrity (0) or not (1);</li> <li>- the 13 remaining bits are reserved;</li> </ul> </li> <li>• the DFEP annotation (18 bytes) as received from the DFEP (cf. DFEP-ICD); it gives in particular the real size of the ISP and shall be used instead of the ISP packet length.</li> </ul> <p>The source packet header must be removed before uncompressing during L1 processing.</p>

#### Compression and Compression by-passed modes:

According to the MSI instrument configuration, the ISPs can be compressed or not. Compression by-passed implies that data for only 4 detectors are provided.

In the nominal products the compression is enabled and all detectors are available; in case of calibration products or contingency acquisition the compression is by-passed and only a subset of detectors are active and therefore available in the product.

The instrument configuration implies that the number of the granules is variable and it is driven by the number of the active detectors.

Though the structure of the L0 Granule PDIs is the same both for compression and by-passed compression, the L0 ISP semantics and data contents (CCSDS packet data field content including IAD (Image Ancillary Data) is different. They host different kind of data (compressed WICOM applied data and uncompressed raw image data) and the IAD is ordered differently (cf. [S2GICD-MSI]). Within the processing chain, granules in compression bypass are dealt with a specific

function in charge of dealing with the different format and perform additional processing tasks usually covered by the WICOM decompressor.

In order to allow properly handle L0 ISP data part, the following metadata are provided at Datastrip level:

- COMPRESS\_MODE metadata (cf. section 3.6.3.1, Table 3-33)
- Active\_Detectors\_List metadata set (cf. section 3.6.3.1, Table 3-33).

To ensure the consistency / completeness of the L0 User Product with on-board compression by-passed a specific ON\_BOARD\_COMPRESSION\_MODE metadata set at product level (cf. section 4.6.7.1, Table 4-9) indicates the compressed or by-passed compressed data content.

Note: all Datastrips in a product will always have the same compression mode. So when dealing with a User Product there is no need to check for the COMPRESS\_MODE flag at Datastrip level. The ON\_BOARD\_COMPRESSION\_MODE flag is sufficient to understand whether the product is relevant to compressed or uncompressed data.

### 3.5.8.3 QI\_DATA

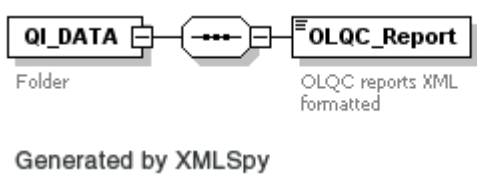
diagram	 <p>Generated by XMLSpy <a href="http://www.altova.com">www.altova.com</a></p>
children	<a href="#">OLQC_Report</a>
annotation	QI_DATA folder contains XML reports generated by On-Line Quality Control processor, including Quality Control Checks results. The Annex C contains the description of OLQC reports.



### 3.5.9 SAFE Manifest synoptic table

This chapter provides a detailed description of the content of the SAFE Manifest for the Level-0 Granule PDI level.

The SAFE Manifest file is compliant to the SAFE specification (cf. [SAFE-SPEC]) and is composed (cf. section 3.4.4) by three main sections (Metadata, Information Package Map and Data Objects).

Part of the information contained in the Metadata section is extracted from the XML metadata file and is therefore duplicated in the SAFE Manifest and in the XML metadata file.

With reference to the three mentioned sections the chapter provides, as a guideline to the generation process of the SAFE Manifest file, the following elements:

- the Table 31 describing the content and structure of the Information Package Map section; consider that this section provides a logical hierarchical view of the product structure and content, reflecting the product organization, through a series of nested XFDU Content Unit elements; each Content Unit represents either a file or a directory contained in the product (except for the root Content Unit that represents the product itself); if it represents a directory, it nests one or more Content Units. In this way, all files of the product (Data Objects, Metadata Objects associated to Data Objects and XSD Schemas associated to Metadata Objects, with the exception of SAFE Manifest file itself) are pointed by the Information Package Map (each Data and Metadata Object by a Content Unit, each Schema by an attribute of the Content Unit); **Note** that for each product the table reflects exactly the product physical structure as graphically shown in the Figure 11 and Figure 12 (or analogous figures for the others PDI and User Product). The correspondences between elements in the figures 11 and 12 and the *contentUnits* in the table is provided in the “Description” column.
- for the Metadata section, Table 32 that lists the fields (tags) composing the section, providing, for each field:
  - the field name in the SAFE Manifest file (column “SAFE Manifest”, divided into column “Metadata name”, containing the name of the Metadata section of the manifest to which the field belongs, and “Name of tag or attribute” containing the actual tag name or attribute name (for sake of clarity, attributes are written in bold characters))
  - the name of the corresponding tag (if available, else N.A.) of the XML Metadata File and of its XSD Schema (column “From S2\_PDI\_Level-0\_Granule\_Metadata.xsd”);
  - a brief textual description of the field;
  - the data type of the field (e.g. string, string enum, integer, double, xs:dateTime etc.);
  - the occurrence of the field (min/man occurrence e.g. 0..1); a minimum occurrence of 1 means that the field is mandatory;
  - the allowed range of values of the field.
- Table 33 describing the content and structure of the Data Objects section; consider that this section contains a reference to each file (Data files and Metadata files) composing the Level-0 Granule PDI (with the exception of the Manifest file itself); this includes:
  - the XML Granule Metadata file;

- the XML Inventory\_Metadata file;
- one file per spectral band, (up to a total of 13 files) in binary format, containing the ISPs corresponding to one detector and one band. in the observation sequence;
- a set of Quality Indicator Data Files, including XML reports about Geometric quality, Image content quality, Quality control checks information

Name					Description	Data Type	Occ
contentUnit					Root Content Unit representing the whole Granule PDI.  (e.g. PDI Level-0 Granule box in Figure 11 or Level-0 Granule PDI_ID header in Figure 12)	U	1
	<b>ID</b>				Unique identifier of Content Unit	S	0..1
	<b>unitType</b>				Type of Content Unit	S	0..1
	<b>textInfo</b>				Textual description of the Component to which the Content Unit refers	S	0..1
	<b>repID</b>				Relate one or more XML Schema Components to a Data Object	S	0..1
	<b>dmdID</b>				Relates the Content Unit to the Platform Metadata Object and, if available, to the Acquisition Period Metadata Object (and to any additional Metadata Object).	S	0..1
	<b>pdilID</b>				Relates the Content Unit to the Processing Metadata Object	S	0..1
	contentUnit				Content Unit representing either a file or a directory of the Granule PDI  (e.g. IMG_DATA box in Figure 11 or IMG_DATA icon in Figure 12)	U	1..*
		<b>ID</b>			Unique identifier of Content Unit	S	0..1
		<b>unitType</b>			Type of Content Unit	S	0..1
		<b>textInfo</b>			Textual description of the Component to which the Content Unit refers	S	0..1
		<b>repID</b>			Relate one or more XML Schema Components to a Data Object	S	0..1
		<b>dmdID</b>			Relates the Content Unit to the Platform Metadata Object and, if available, to the Acquisition Period Metadata Object (and	S	0..1

					to any additional Metadata Object).		
		.....			Further level of nesting (if any) of Content Units		
		.....			Further level of nesting (if any) of Content Units		
		contentUnit			Terminal leaf in the product structure hierarchy; this Content Unit represents a Data/Metadata Component file of the Granule PDI  (e.g. S2A_OPER_MSI_L0_GR_MTI_20141104T134012_S20141104T134012_D01_B01.bin file li Figure 12)		
			<b>ID</b>		Unique identifier of Content Unit	S	0..1
			<b>unitType</b>		Type of Content Unit	S	0..1
			<b>textInfo</b>		Textual description of the Component to which the Content Unit refers	S	0..1
			<b>replID</b>		Relate one or more XML Schema Components to a Data Object	S	0..1
			<b>dmdID</b>		Relates the Content Unit to the Platform Metadata Object and, if available, to the Acquisition Period Metadata Object (and to any additional Metadata Object).	S	0..1
			<b>dataObjectPointer</b>		Pointer to the Data/Metadata Component represented by the Content Unit	U	1
				<b>dataObjectID</b>	Identifier of Data/Metadata Component in the Data Objects section of the SAFE Manifest	S	1

Table 31 – Content of Information Package Map for PDI Level-0 Granule SAFE Manifest

SAFE Manifest		From <i>S2_PDI_Level-0_Granule_Metadata.xsd</i>	Description	Data Type	Occurrence	Allowed range of values
Metadata name	Name of tag or attribute (in bold)	Tag name				
platform						
	nssdcIdentifier	N.A.	Unique identifier of the platform, defined by the World Data Center for Satellite Information (WDC-SI)		1	WDC is discontinued; this tag is set to a default value 0000-0000
	familyName	General_Info->GRANULE_ID (substring <Mission ID>, cf. section 3.5.6)	The mission name of the platform		0..1	Sentinel
	number	General_Info->GRANULE_ID (substring <Mission ID>, cf. section 3.5.6)	Sequence identifier of the platform among the mission	string enum	0..1	2A, 2B, 2C
	instrument->familyName	N.A.	The instrument name used for acquiring the product data	string enum	0..1	Multi-Spectral Instrument
	instrument-> <b>abbreviation</b>	N.A.	Abbreviation of the instrument name	string enum	0..1	MSI
	instrument->mode	N.A.	The mode of the instrument	string enum	0..1	Nominal_Observation Dark_Signal_Calibration Extended_Observation Absolute_Radiometry_Calibration Vicarious_Calibration Raw_Measure

SAFE Manifest		From S2_PDI_Level-0_Granule_Metadata.xsd	Description	Data Type	Occurrence	Allowed range of values
Metadata name	Name of tag or attribute (in bold)	Tag name				
						ment Test_Mode
	instrument->mode-> <b>identifier</b>	N.A.	The identifier of the instrument mode	string enum	1	INS-NOBS INS-EOBS INS-DASC INS-ABSR INS-VIC INS-RAW INS-TST
processing			Textual description of the history of processings that lead to the current product and of all the relevant resources involved in the processing (facilities, software, applicable documents etc)		1	
	<b>name</b>	N.A.	Name of the Archiving process	string	0..1	Archiving of PDI Level-1A Datastrip Product
	<b>start</b>	General_Info->Archiving_Info -> ARCHIVING_TIME	Archiving start date (UTC)	xs:dateTime	0..1	
	facility		Description of Origin Centre		0..*	
	facility-> <b>name</b>	N.A.	Extended name of Origin Centre	string	1	
	facility-> <b>organization</b>	N.A.	Organization to which the Origin center belongs	string	0..1	



## Sentinel-2 Products Specification Document

REF : S2-PDGS-TAS-DI-PSD  
 ISSUE : 14.5  
 DATE : 14/03/2018  
 PAGE : 110 / 510

SAFE Manifest		From S2_PDI_Level-0_Granule_Metadata.xsd	Description	Data Type	Occurrence	Allowed range of values
Metadata name	Name of tag or attribute (in bold)	Tag name				
	facility-> <b>site</b>	General_Info-> Archiving_Info ->ARCHIVING_CENTRE	The starting point of the circulation data	string enum	0..1	SGS_ MPS_ MTI_ EPA_ UPA_ CDAM_ MPC_
	facility-> <b>country</b>	N.A.	Country where Origin Centre is located	string	0..1	
	resource		Description of product being archived		0..*	
	resource-> <b>name</b>	N.A.	Name of the product being archived	string	1	
	processing-> resource-> <b>role</b>	N.A.	Role of the resource	string	1	PDI Level-1A Granule Product
	resource-> processing		Description of the L0 to L1A Processing		0..*	
	resource-> processing-> <b>name</b>	N.A.	Name of the L0 to L1A Processing	string	0..1	Processing of Level-0 Granule product
	resource-> processing-> <b>start</b>	General_Info-> GRANULE_ID (substring <Creation Date>, cf.section 3.5.6)	Processing start date (UTC)	xs:dateTime	0..1	
	resource-> processing-> facility	N.A.	Description of Processing Centre		0..*	
	resource-> processing-> facility-> <b>name</b>	N.A.	Extended name of Origin Centre	string	1	



SAFE Manifest		From S2_PDI_Level-0_Granule_Metadata.xsd	Description	Data Type	Occurrence	Allowed range of values
Metadata name	Name of tag or attribute (in bold)	Tag name				
	resource->processing->facility-> <b>organization</b>	N.A.	Organization to which the Origin center belongs	string	0..1	
	resource->processing->facility-> <b>site</b>	General_Info->GRANULE_ID (substring <Site Centre>)	Acronym of the Processing center	string enum	0..1	SGS_ MPS_ MTI_ EPA_ MPC_ UPA_ XXXX EDRS zzzL (zzz = first three characters of the LGS location)
	resource->processing->facility-> <b>country</b>	N.A.	Country where Origin Centre is located	string	0..1	
	resource->processing->facility->software	N.A.	Description of software component used for Processing		0..*	
	resource->processing->facility->software-> <b>name</b>	N.A.	Name of the software component	string	1	
	resource->processing->facility->software-> <b>version</b>	N.A.	Version of the software component	string	0..1	
acquisitionPeriod					1	

SAFE Manifest		From S2_PDI_Level-0_Granule_Metadata.xsd	Description	Data Type	Occurrence	Allowed range of values
Metadata name	Name of tag or attribute (in bold)	Tag name				
	startTime	General_Info->GRANULE_ID (substring <Sensing Time>, cf.section 3.5.6)	Reference time of acquisition of the Granule (corresponding to sensing time of the first line of the PDI at Granule level, cf. section 3.5.6)	xs:dateTime	1	
measurementFrameSet					1	
	cloudVoteNotationSystem-> <b>floor</b>	N.A.	Minimum value of cloud coverage index (Fixed value = 0.0)	double	0..1	0.0
	cloudVoteNotationSystem-> <b>ceil</b>	N.A.	Maximum value of cloud coverage index (Fixed value = 100.0)	double	0..1	100.0
	frame	N.A.	The "frame" concept is used in SAFE to convey the cloud coverage information by subdividing the region of interest of the data into "frames" according to a World Reference System. In the case of Sentinel-2 L1C Products, a similar concept can be used, by associating one single "frame" to the area covered by the granule (with respect to the reference band)		0..13	
	frame->number	N.A.	Number of the frame	integer	0..1	1





**Sentinel-2 Products  
Specification Document**

REF : S2-PDGS-TAS-DI-PSD  
ISSUE : 14.5  
DATE : 14/03/2018  
PAGE : 113 / 510

SAFE Manifest		From S2_PDI_Level-0_Granule_Metadata.xsd	Description	Data Type	Occurrence	Allowed range of values
Metadata name	Name of tag or attribute (in bold)	Tag name				
	frame-center	Geometric_Info->Granule_Position->Geometric_Header->GROUND_CENTER (only lat/lon coordinates, not height)	The Granule centre on ground	gml:PointType	0..1	
	frame->footPrint	Derived from Geometric_Info->Granule_Footprint	Granule footprint (namely imaged area corresponding to the Granule), corresponding to one detector and all bands	string (gml:linearRingType namely blank separated list of comma-separated long/lat coordinates of footprint closed polygon with last vertex equal to first)	0..1	
	frame->Tile	N.A.			1	One Tile for the frame
	frame->Tile->row	N.A.	The column index of the Tile. This index is numbered starting from 1.	integer	1	1 (since there is only one Tile)
	frame->Tile->column	N.A.	The row index of the Tile. This index is numbered starting from 1.	integer	1	1 (since there is only one Tile)
	frame->Tile->cloudVote	Derived from Quality_Indicators_Info->Image_Content_QI->Common_IMG_QI->CLOUDY_PIXEL_PERCENTAGE	Numeric notation qualifying the cloud coverage of the Tile	double	0..1	0 to 100
metadataComponents		N.A.	A reference to all Metadata files included in the product (e.g. the XML Metadata file, the XML Inventory Metadata file)		2..10	
metadataComponentSchemas		N.A.	A reference to the Schemas used to validate the Metadata files included in the product (e.g. the XML Metadata file Schema)		0..2	



Table 32 - Content of Metadata Section for PDI Level-0 Granule SAFE Manifest

Name			Description	Data Type	Occ
dataObject			This element references the Data Component included in the product.	U	1..*
	<b>ID</b>		Data Component;ID	S	1
	<b>repld</b>		List of IDs of all XML Schemas associated to Data Component	S	1
	byteStream		Pointer to the Data Component	U	1..*
		<b>mimeType</b>	The MIME type for the referenced Data Component	E	1
		<b>size</b>	The size in bytes of the Data Component	UI	1
		fileLocation	Location of file	U	1
			<b>locatorType</b>	URI	1
			<b>textInfo</b>	S	0..1
			<b>href</b>	URI	1
		checksum	Checksum value for the Data Component	U	1
			<b>checksumName</b>	E	1

Table 33 – Content of Data Object Section for PDI Level-0 Granule SAFE Manifest



**Sentinel-2 Products  
Specification Document**

REF : S2-PDGS-TAS-DI-PSD  
ISSUE : 14.5  
DATE : 14/03/2018  
PAGE : 115 / 510



### 3.6 Level-0 Datastrip PDI definition

Level-0 Datastrip PDI is defined as a tar file containing the following structure:

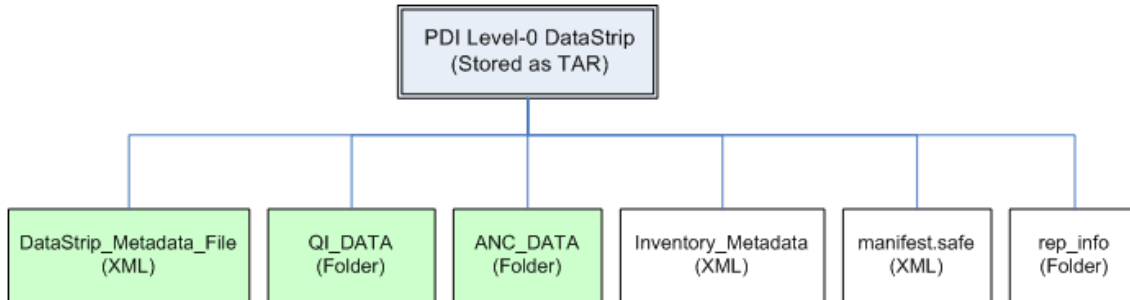

Figure 18: PDI Level-0 Datastrip Structure

The PDI Level-0 Datastrip consists of:

1. **Datastrip\_Metadata\_File**: XML metadata file containing the requested level of information and referring all the product elements composing the Datastrip;
2. **QI\_DATA**: folder containing the preliminary QuickLook files in JP2 format and XML reports providing Quality control check results;
3. **ANC\_DATA**: folder containing SAD raw data provided on temporal extent of the full Datatake if the Datastrip is the last one in a given Datatake, otherwise the SAD coverage is from the start of the Datatake (to which the Datastrip belongs to) to the stop of the Datastrip itself. SAD data are provided as a set of unitary Raw Data files each matching a single packet type;
4. **Inventory\_Metadata.xml**: file containing the metadata needed to inventory the PDI;
5. **manifest.safe**: XML SAFE Manifest file (mandatory, cf. section 3.6.4);
6. **rep\_info**: folder containing the available XSD schemas that validate the PDI components (recommended by [SAFE-SPEC], cf. section 3.4.4).

#### 3.6.1 PDI\_ID definition

Datastrip PDI\_ID (Datastrip ID) is defined in the section 3.5.2. The File\_Type is specified in the section 3.2, Table 5.

Level-0 Datastrip template Name (Datastrip ID):

*S2A\_OPER\_MSI\_L0\_DS\_SGS\_20141104T134012\_S20141104T134012\_N01.12.tar*

Note that the PDI\_ID.tar is the physical name of the Datastrip PDI after the tar compression.

### 3.6.2 Level-0 Datastrip Physical Format

The PDI ID defined above represents the “Datastrip directory” name. Inside the Datastrip directory, there are the Datastrip components as in the Figure 18.

Inside that directory, the naming convention used to identify each real file follows the same convention used to define the Datastrip ID but without the Processing Baseline sub-string.

- **Datastrip\_Metadata\_File (XML file):**

Datastrip\_Metadata\_File template name:

*S2A\_OPER\_MTD\_L0\_DS\_SGS\_20141104T134012\_S20141104T134012.xml*

The XSD schema, which regulates the metadata file, is *S2\_PDI\_Level-0\_Datastrip\_Metadata.xsd* included in the *S2-PDGS-TAS-DI-PSD-V14\_Schemas.zip* file annexed to the document.

- **QI\_DATA (folder):**

QI\_DATA folder contains:

- XML reports *OLQC\_Report.xml* generated by On-Line Quality Control processor, including Quality Control Checks results. The *OLQC\_Report.xsd* schema and the reports naming convention are in the Annex C of the document.

File Template Name:

*S2A\_OPER\_MSI\_L0\_DS\_SGS\_20141104T134012\_S20141104T134012\_GEOMETRIC\_QUALITY\_report.xml*

- Five (5) Preliminary Quick Look files (JPEG2000 format). The number of files could be potentially less than 5 in degraded cases.

Naming convention = MMM\_CCCC\_TTTTTTTTTT\_<Instance\_ID>.jp2

<Instance\_Id> = <Site Centre>\_<Creation Date>\_<Sensing Time>\_<Band Id>

MMM, CCCC, <Site Centre> and <Sensing Time> are taken from L0 Datastrip ID.

TTTTTTTTTT = QLK\_L0\_DS

<Band Id> = Bxx where xx = 01, 02, 03, 04, 05, 06, 07, 08, 8A, 09, 10, 11, 12

The <Band Id> is configurable but the default values are: 01, 02, 03, 10 and 11

File Template Name:

*S2A\_OPER\_QLK\_L0\_DS\_SGS\_20141104T134012\_S20141104T134012\_B11.jp2*

- **ANC\_DATA (folder):**

ANC\_DATA folder contains:

- Raw Satellite Ancillary Data provided as a set of unitary Raw Data files each matching a single packet type.

File template name (cf. section 3.22.1):

S2A\_OPER\_AUX\_S11125\_SGS\_YYYYMMDDTHHMMSS\_VYYYYMMDDTHHMMSS\_YYYYMMD  
 DTHHMMSS\_A012631\_WF\_LN.bin

- **Inventory\_Metadata (XML file):**  
XML Inventory metadata file with fixed name *Inventory\_Metadata.xml*
  
- **rep\_info (folder):**  
Folder containing the following XSD schemas:
  1. S2\_PDI\_Level-0\_Datastrip\_Metadata.xsd
  2. Inventory\_Metadata.xsd
  3. OLQC\_Report.xsd

Level-0 Datastrip Physical Format template:

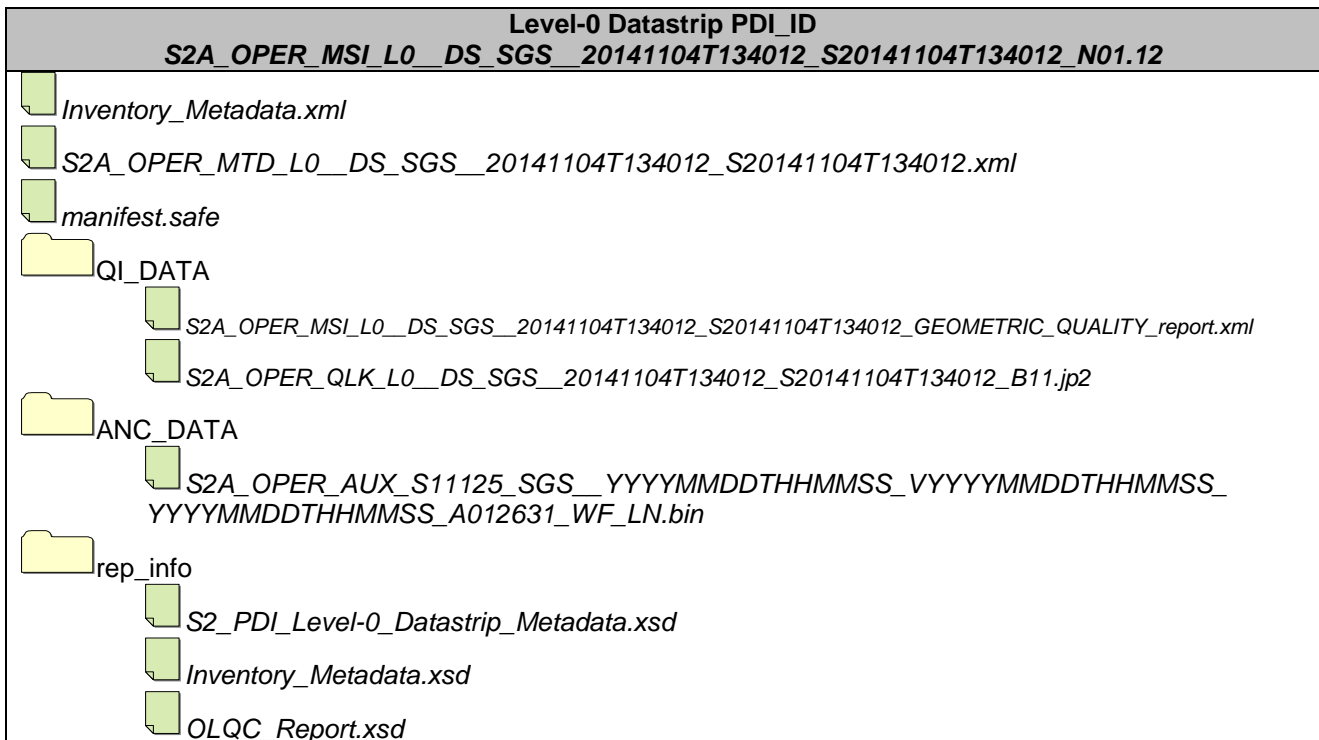
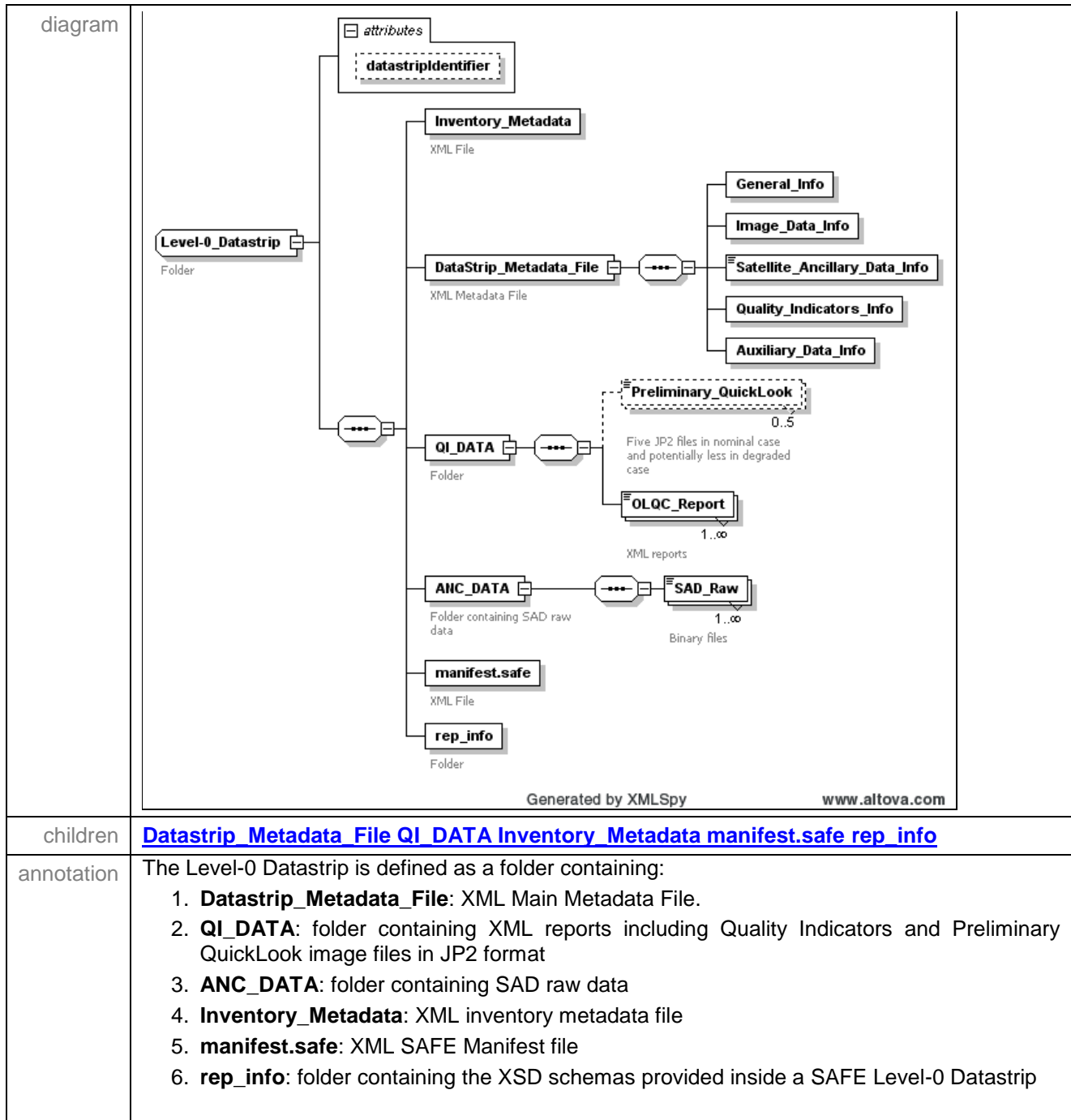

Figure 19: PDI Level-0 Datastrip Physical Format

### 3.6.3 Level-0 Datastrip PDI Structure

The *S2\_PDI\_Level-0\_Datastrip\_Structure.xsd* schema annexed to the document and shown in the following diagram, represents the organization of a Level-0 Datastrip PDI on disk. This schema is provided for information only as it is actually not expected to be used for the validation of a XML file. The diagram reflects exactly the Figure 18.



Note that ANC\_DATA, Inventory\_Metadata.xml, manifest.safe and rep\_info are removed when the PDI is included in the User Product.

### 3.6.3.1 Datastrip\_Metadata\_File Schema

Level-0 Datastrip\_Metadata\_File is the XML metadata file provided inside each Level-0 Datastrip. The schema used to validate it is *S2\_PDI\_Level-0\_Datastrip\_Metadata.xsd* annexed to this document. A detailed description of the schema is given here but for specific details regarding each metadata (e.g. type, default value, fixed value, enumerations, occurrences, etc...) refers to the XSD file.

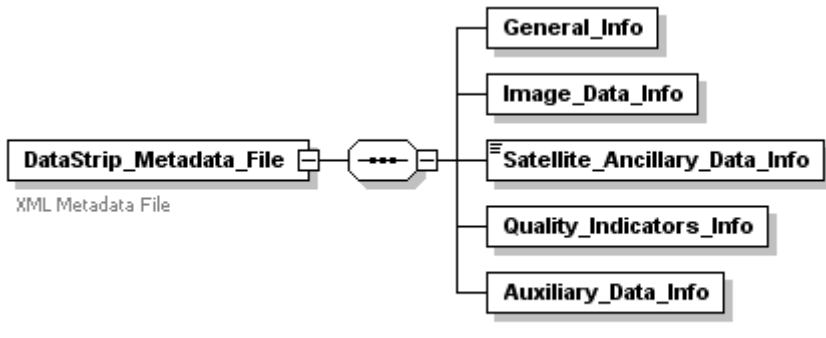
diagram	 <p align="center">Generated by XMLSpy <span style="float:right">www.altova.com</span></p>
children	<a href="#">General_Info</a> <a href="#">Image_Data_Info</a> <a href="#">Satellite_Ancillary_Data_Info</a> <a href="#">Quality_Indicators_Info</a> <a href="#">Auxiliary_Data_Info</a>
annotation	<p>The structure of the Datastrip_Matadata_File is common to all processing level (cfr. § 3.5.1)          The Datastrip_Metadata_File is an XML file containing all the metadata describing the whole product data item.</p> <ol style="list-style-type: none"> <li><b>General_Info:</b> This group of metadata provide general information characterizing the source Datastrip acquisition.</li> <li><b>Image_Data_Info:</b> Image data information from MSI telemetry.</li> <li><b>Satellite_Ancillary_Data_Info:</b> Ancillary data information from Satellite Ancillary Telemetry.</li> <li><b>Quality_Indicators_Info:</b> Results of all quality checks performed at Datastrip level.</li> <li><b>Auxiliary_Data_Info:</b> Auxiliary data information.</li> </ol>

The following tables and figures give a complete overview of the Level-0 Datastrip\_Metadata\_File schema according the description provided in the section 3.5.1.



## General Info:

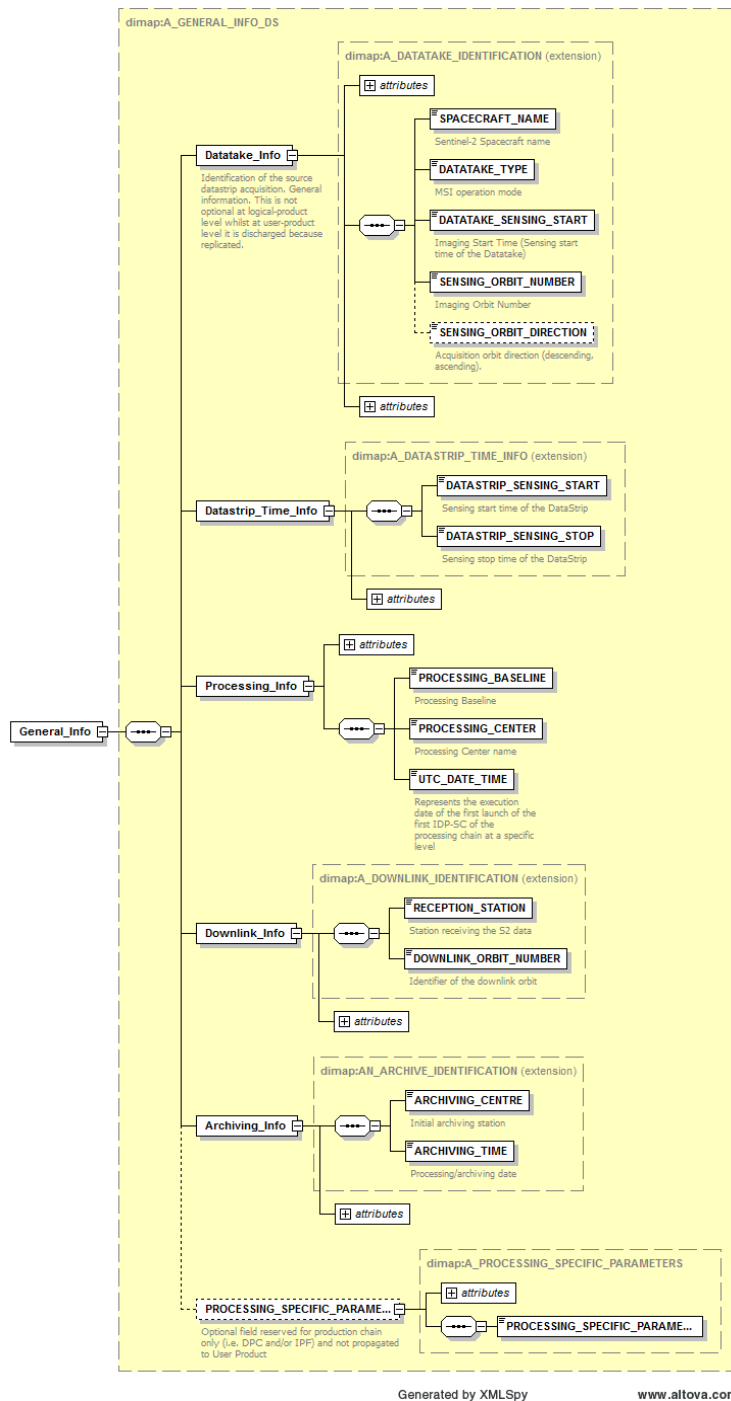

Figure 20: Level-0 Datastrip - General\_Info Diagram



**Sentinel-2 Products  
Specification Document**

REF : S2-PDGS-TAS-DI-PSD  
 ISSUE : 14.5  
 DATE : 14/03/2018  
 PAGE : 122 / 510

In the following tables, the third column provides the metadata level attribute for each metadata (cf. section 2.10).

General_Info/Datatake_Info		
Field Name	Description	Metatada Level
SPACECRAFT_NAME	Sentinel-2 Spacecraft name: Sentinel-2A, Sentinel-2B	Brief
DATATAKE_TYPE	MSI operation mode	Brief
DATATAKE_SENSING_START	Imaging Start Time (Sensing start time of the Datatake)	Brief
SENSING_ORBIT_NUMBER	Imaging Orbit Number  ESA confirms that SENSING_ORBIT_NUMBER has to be filled by the 'Relative' orbit number which is computed from the Absolute as reported in DPM-IAS02.	Brief
SENSING_ORBIT_DIRECTION	Imaging Orbit Direction (Default = Ascending)	Brief
General_Info/Datastrip_Time_Info		
Field Name	Description	Metatada Level
DATASTRIP_SENSING_START	Sensing start time of the Datastrip	Brief
DATASTRIP_SENSING_STOP	Sensing stop time of the Datastrip	Brief
General_Info/Processing_Info		
Field Name	Description	Metatada Level
PROCESSING_BASELINE	The processing baseline (cf. section 2.9) refers to the configuration baseline used at the time of the product generation in term of processor software version and major GIPP version.  Note: all the PDIs of a Datatake are always processed with the same processing baseline	Expertise





**Sentinel-2 Products  
Specification Document**

REF : S2-PDGS-TAS-DI-PSD  
 ISSUE : 14.5  
 DATE : 14/03/2018  
 PAGE : 123 / 510

UTC_DATA_TIME	even if acquired in different stations This data time represents the execution date of the first run of the first IDP-SC of the processing chain at a specific level	Expertise
PROCESSING_CENTER	Production centre: <ul style="list-style-type: none"> <li>• SGS_</li> <li>• MPS_</li> <li>• MTI_</li> <li>• EPA_</li> <li>• MPC_</li> <li>• UPA_</li> <li>• XXXX</li> <li>• EDRS</li> <li>• zzzL (zzz = first three characters of the LGS location)</li> </ul>	Expertise
<b>General_Info/Downlink_Info</b>		
<b>Field Name</b>	<b>Description</b>	<b>Metatada Level</b>
RECEPTION_STATION	Reception stations: <ul style="list-style-type: none"> <li>• SGS_</li> <li>• MPS_</li> <li>• MTI_</li> </ul>	Standard
DOWNLINK_ORBIT_NUMBER	Identifier of the downlink orbit	Standard
<b>General_Info/Archiving_Info</b>		
<b>Field Name</b>	<b>Description</b>	<b>Metatada Level</b>
ARCHIVING_CENTRE	The allowed values are: <ul style="list-style-type: none"> <li>• SGS_</li> <li>• MPS_</li> <li>• MTI_</li> <li>• EPA_</li> <li>• UPA_</li> <li>• CDAM</li> <li>• MPC_</li> </ul>	Expertise
ARCHIVING_TIME	Archiving date (UTC data time). Date	Expertise





**Sentinel-2 Products  
Specification Document**

REF : S2-PDGS-TAS-DI-PSD  
ISSUE : 14.5  
DATE : 14/03/2018  
PAGE : 124 / 510

	updated at the end of inventory process	
Processing_Specific_Parameters/PROCESSING_SPECIFIC_PARAMETERS	Optional field reserved for production chain only (NOT propagated to User Product)	Expertise

Table 34: Level-0 Datastrip - General\_Info Description



Image Data Info:

The exploited Image\_Data\_Info diagram is too complex to be inserted in the document. The following figure shows the high-level diagram, for more details refers to the S2\_PDI\_Level-0\_Datastrip\_Metadata.xsd contained in the S2-PDGS-TAS-DI-PSD-V14\_Schemas.zip annexed to this document. The table hereafter describes all the Image Data Information.

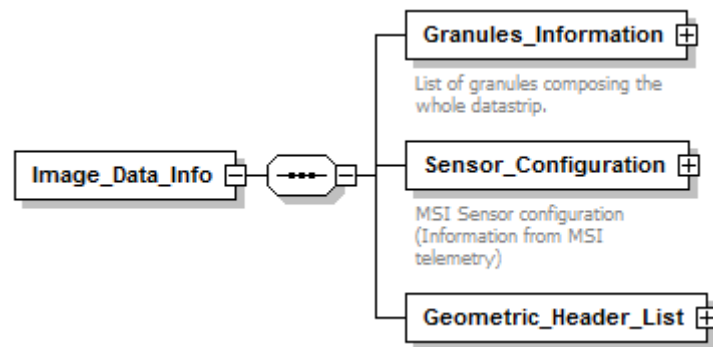

Figure 21 : Level-0 Datastrip – Image\_Data\_Info Diagram



## Sentinel-2 Products Specification Document

REF : S2-PDGS-TAS-DI-PSD  
 ISSUE : 14.5  
 DATE : 14/03/2018  
 PAGE : 126 / 510

Image_Data_Info/Granules_Information		
Field Name	Description	Metatada Level
/Detector_List/.../POSITION	This branch of the schema provides information regarding all Granules, for each detector, composing the whole Datastrip. Each Granule composing the Datastrip is univocally identified through a unique Granule identifier (PDI_ID at granul level). For each Granule the Position of the Granule is provided. This position is identified through the position of the scenes first lines in the Datastrip and is expressed as number of 10m resolution images lines.	Standard
Image_Data_Info/Sensor_Configuration		
Field Name	Description	Metatada Level
Acquisition_Configuration/COMPRESS_MODE	Flag to indicate if compress mode is by passed	Expertise
Acquisition_Configuration/EQUALIZATION_MODE	Flag to indicate if equalization is active	Expertise
Acquisition_Configuration/NUC_TABLE_ID	In-flight Non Uniform Correction table ID defined by 10 bits. This ID is uniform for all transmitted bands. It identifies the correction coefficients table used in-flight	Expertise
Acquisition_Configuration/Active_Detectors_List/ACTIVE_DETECTOR	On board active Detectors (in case of compression by-passed)  Note: Metadata classified <i>Brief</i> (always provided) in order to have always available in the L0 User Product the list of active detectors for each MSI mode. This to ensure the consistency/completeness of the L0 User Product with on-board compression by-passed or not.  The list of active detectors is variable and this metadata drives the list of the L0 Granule PDI available in the L0 User Product	Expertise
Acquisition_Configuration/TDI_Configuration_List/TDI_CONFIGURATION	On board TDI configuration, for B3, B4, B11 and B12 only.	Standard
Acquisition_Configuration/Spectral_Band_Info/PHYSICAL_GAINS	Physical Gain for each band	Standard
Acquisition_Configuration/Spectral_Band_Info/COMPRESSION_RATE	On-board compression rates for each band	Expertise





## Sentinel-2 Products Specification Document

REF : S2-PDGS-TAS-DI-PSD  
 ISSUE : 14.5  
 DATE : 14/03/2018  
 PAGE : 127 / 510

Acquisition_Configuration/Spectral_Band_Info/INTEGRATION_TIME	On-board integration time for each band	Expertise
Source_Packet_Description/Source_Packet_Counters_List/Detector_List/Band_List/Band/DATA_STRIP_START	First source packet counter	Standard
Source_Packet_Description/Source_Packet_Counters_List/Detector_List/Band_List/Band/SCENE_POSITION	Position of the first source packet in the on board scen	Standard
Source_Packet_Description/Source_Packet_Counters_List/Detector_List/Band_List/Band/NB_OF_SOURCE_PACKETS	Number of source packets.	Standard
Source_Packet_Description/Degradation_Summary Attribute: degradationPercentage	Percentage of lost or degraded (either too degraded or not) ancillary data packets in the Datastrip	-
Source_Packet_Description/Degradation_Summary/NUMBER_OF_LOST_PACKETS	Number of lost packets for the whole Datastrip	Standard
Source_Packet_Description/Degradation_Summary/NUMBER_OF_TOO_DEGRADED_PACKETS	Number of too degraded packets (i.e. erroneous packets not trustworthy, meaning they will not be used by further processing) for the whole Datastrip	Standard
Source_Packet_Description/Degradation_Summary/NUMBER_OF_KEPT_DEGRADED_PACKETS	Number of degraded packets (i.e. erroneous packets but trustworthy, meaning they will be used by further processing) for the whole Datastrip	Standard
Time_Stamp/LINE_PERIOD	Line period for the acquisition of line of 10 m full-resolution image data	Standard
Time_Stamp/Band_Time_Stamp/Detector/REFERENCE_LINE	Datation model for each couple band, detector. Line number corresponding to the time stamp	Standard
Time_Stamp/Band_Time_Stamp/Detector/GPS_TIME	Datation model for each couple band, detector. Time stamp.	Standard
Time_Stamp/GPS_SYNC	Flag (Boolean) to indicate if MSI is synchronize with GPS time	Standard
Time_Stamp/THEORETICAL_LINE_PERIOD	Theoretical line period for the acquisition of line of 10 m full-resolution image data	Standard
Time_Stamp/Quality_Indicators/Global/RMOY	GPS time quality indicator.  Optional. Created when datation models are estimated through linear regression.	Standard
Time_Stamp/Quality_Indicators/GSP_List/GSP/RMOY	Optional. Created when datation models are estimated through linear regression.	Standard
<b>Image Data Info/Geometric Header List</b>		
<b>Field Name</b>	<b>Description</b>	<b>Metatada Level</b>





**Sentinel-2 Products  
Specification Document**

REF : S2-PDGS-TAS-DI-PSD  
ISSUE : 14.5  
DATE : 14/03/2018  
PAGE : 128 / 510

Geometric_Header_List/Geometric_Header/GPS_TIME	A GPS date-time value = TAI format	Standard
Geometric_Header_List/Geometric_Header/LINE_INDEX	Line index (Integer)	Standard
Geometric_Header_List/Geometric_Header/Pointing_Angles/Satellite_Reference/ROLL	double value expressed in degree	Standard
Geometric_Header_List/Geometric_Header/Pointing_Angles/Satellite_Reference/PITCH	double value expressed in degree	Standard
Geometric_Header_List/Geometric_Header/Pointing_Angles/Satellite_Reference/YAW	double value expressed in degree	Standard
Geometric_Header_List/Geometric_Header/Pointing_Angles/Image_Reference/PSI_X	Along lines	Expertise
Geometric_Header_List/Geometric_Header/Pointing_Angles/Image_Reference/PSI_Y	Along columns	Expertise
Geometric_Header_List/Geometric_Header/Located_Geometric_Header/ORIENTATION	Track orientation. Also called "CAPE". The range of the angle is into [0,360°[	Standard
Geometric_Header_List/Geometric_Header/Located_Geometric_Header/Incidence_Angles/ZENITH_ANGLE	incidence zenith angle	Standard
Geometric_Header_List/Geometric_Header/Located_Geometric_Header/Incidence_Angles/ZENITH_ANGLE	incidence azimuth angle	Standard
Geometric_Header_List/Geometric_Header/Located_Geometric_Header/Solar_Angles/ZENITH_ANGLE	solar azimuth angle	Standard
Geometric_Header_List/Geometric_Header/Located_Geometric_Header/Solar_Angles/ZENITH_ANGLE	solar azimuth angle	Standard
Geometric_Header_List/Geometric_Header/Located_Geometric_Header/Pixel_Size/ALONG_TRACK	pixel size along track	Standard
Geometric_Header_List/Geometric_Header/Located_Geometric_Header/Pixel_Size/ACROSS_TRACK	pixel size across track	Standard

Table 35: Level-0 Datastrip – Image\_Data\_Info Description





Satellite Ancillary Data Info:

The expanded `Satellite_Ancillary_Data_Info` diagram is too complex to be inserted in the document. The following figure shows the high-level diagram, for more details refers to the `S2_PDI_Level-0_Datastrip_Metadata.xsd` contained in the S2-PDGS-TAS-DI-PSD-V14\_Schemas.zip annexed to this document.

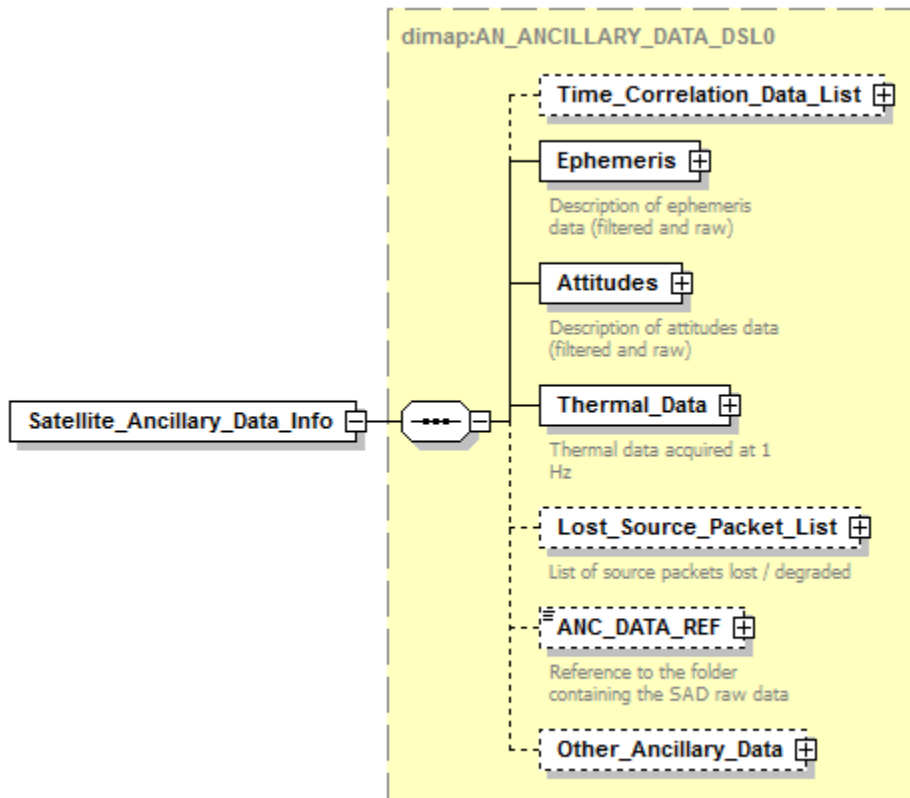

Generated by XMLSpy

www.altova.com

Figure 22: Level-0 Datastrip – `Satellite_Ancillary_Data_Info` Diagram



## Sentinel-2 Products Specification Document

REF : S2-PDGS-TAS-DI-PSD  
 ISSUE : 14.5  
 DATE : 14/03/2018  
 PAGE : 130 / 510

Satellite Ancillary Data Info		
Field Name	Description	Metatada Level
Satellite_Ancillary_Data_Info/Time_Correlation_Data_List/Time_Correlation_Data/NSM	Navigation Solution Method	Standard
Satellite_Ancillary_Data_Info/Time_Correlation_Data_List/Time_Correlation_Data/QUALITY_INDEX	Time quality index	Standard
Satellite_Ancillary_Data_Info/Time_Correlation_Data_List/Time_Correlation_Data/TDOP	Time dilution of precision.	Standard
Satellite_Ancillary_Data_Info/Time_Correlation_Data_List/Time_Correlation_Data/IMT	Instrument measurement time representation of the synchronisation time stamp.	Standard
Satellite_Ancillary_Data_Info/Time_Correlation_Data_List/Time_Correlation_Data/GPS_TIME	GPS time representation of the synchronisation time stamp.	Standard
Satellite_Ancillary_Data_Info/Time_Correlation_Data_List/Time_Correlation_Data/UTC_TIME	UTC time representation of the synchronisation time stamp.	Standard
Satellite_Ancillary_Data_Info/Ephemeris/GPS_Number_List/Gps_Number/GPS_TIME_START	GPS time value. This field must be filled by the processor according to each GPS time period.	Standard
Satellite_Ancillary_Data_Info/Ephemeris/GPS_Number_List/Gps_Number/GPS_TIME_END	GPS time value. This field must be filled by the processor according to each GPS time period.	Standard
Satellite_Ancillary_Data_Info/Ephemeris/GPS_Points_List/GPS_Point/POSITION_VALUES	Dated positions (X, Y, Z) from GPS in millimeters	Standard
Satellite_Ancillary_Data_Info/Ephemeris/GPS_Points_List/GPS_Point/POSITION_ERRORS	Position errors (dX, dY, dZ) from GPS in millimeters	Standard
Satellite_Ancillary_Data_Info/Ephemeris/GPS_Points_List/GPS_Point/VELOCITY_VALUES	Dated velocities (Vx, Vy, Vz) from GPS in millimeters per seconds	Standard
Satellite_Ancillary_Data_Info/Ephemeris/GPS_Points_List/GPS_Point/VELOCITY_ERRORS	Velocity errors (dVx, dVy, dVz) from GPS in millimeters per seconds	Standard
Satellite_Ancillary_Data_Info/Ephemeris/GPS_Points_List/GPS_Point/GPS_TIME	GP's Time value	Standard
Satellite_Ancillary_Data_Info/Ephemeris/GPS_Points_List/GPS_Point/NSM	Navigation Solution Method	Standard
Satellite_Ancillary_Data_Info/Ephemeris/GPS_Points_List/GPS_Point/QUALITY_INDEX	Position quality index	Standard
Satellite_Ancillary_Data_Info/Ephemeris/GPS_Points_List/GPS_Point/GDOP	Quality index (Geometrical dilution of precision)	Standard





## Sentinel-2 Products Specification Document

REF : S2-PDGS-TAS-DI-PSD  
 ISSUE : 14.5  
 DATE : 14/03/2018  
 PAGE : 131 / 510

Satellite_Ancillary_Data_Info		
Field Name	Description	Metatada Level
Satellite_Ancillary_Data_Info/Ephemeris/GPS_Points_List/GPS_Point/PDOP	Quality index (Position dilution of precision)	Standard
Satellite_Ancillary_Data_Info/Ephemeris/GPS_Points_List/GPS_Point/TDOP	Quality index (Time dilution of precision)	Standard
Satellite_Ancillary_Data_Info/Ephemeris/GPS_Points_List/GPS_Point/NOF_SV	The number of Space Vehicless (SVs) the receiver was able to use for the Navigation Solution computation, i.e. SVs for which code and carrier phase measurements and Ephemeris data were available.	Standard
Satellite_Ancillary_Data_Info/Ephemeris/GPS_Points_List/GPS_Point/TIME_ERROR	GNSS system time error	Standard
Satellite_Ancillary_Data_Info/Ephemeris/AOCS_Ephemeris_List/AOCS_Ephemeris/VALID_FLAG	When 1 : ephemeris is valid	Standard
Satellite_Ancillary_Data_Info/Ephemeris/AOCS_Ephemeris_List/AOCS_Ephemeris/OPSOL_QUALITY	0: solution is valid / 1: solution propagated / 2: cyclic position update available	Standard
Satellite_Ancillary_Data_Info/Ephemeris/AOCS_Ephemeris_List/AOCS_Ephemeris/POSITION_VALUES	Dated positions (X, Y, Z) from AOCS	Standard
Satellite_Ancillary_Data_Info/Ephemeris/AOCS_Ephemeris_List/AOCS_Ephemeris/VELOCITY_VALUES	Dated velocities (Vx, Vy, Vz) from AOCS	Standard
Satellite_Ancillary_Data_Info/Ephemeris/AOCS_Ephemeris_List/AOCS_Ephemeris/GPS_TIME	GPs Time value	Standard
Satellite_Ancillary_Data_Info/Ephemeris/AOCS_Ephemeris_List/AOCS_Ephemeris/ORBIT_ANGLE	Orbit angle wrt WGS84	Standard
Satellite_Ancillary_Data_Info/Ephemeris/POD_Info/POD_FLAG	Flag to indicate if POD (Precise Orbit Determination) data has been used for product generation  Note: POD_Info optional node is not relevant in case of L0 and L1C processing but it is included here to have the same Satellite_Ancillary_Data information for all level of processing.	Standard
Satellite_Ancillary_Data_Info/Ephemeris/POD_Info/POD_FILENAME	POD filename. If applicable, reference to the file containing POD data used.	Standard
Satellite_Ancillary_Data_Info/Attitudes/Corrected_Attitudes/Values/QUATERNION_VALUES	Space separated list of 4 quaternion values ordered as Q0 Q1 Q2 Q3 (qv1 qv2 qv3 qs)	Standard
Satellite_Ancillary_Data_Info/Attitudes/Corrected_Attitudes/Values/QUATERNION_VALIDITY	When 1 : quaternion is valid	Standard





## Sentinel-2 Products Specification Document

REF : S2-PDGS-TAS-DI-PSD  
 ISSUE : 14.5  
 DATE : 14/03/2018  
 PAGE : 132 / 510

Satellite_Ancillary_Data_Info		
Field Name	Description	Metatada Level
Satellite_Ancillary_Data_Info/Attitudes/Corrected_Attitudes/Values/GPS_TIME	GPs Time value	Standard
Satellite_Ancillary_Data_Info/Attitudes/Corrected_Attitudes/Values/INUSE_FLAGS	List of 11 boolean flags separated by whitespace: STR1 STR2 STR3 GPSR-A GPSR-B VCU-A VCU-B IMU-1 IMU-2 IMU-3 IMU-4	Standard
Satellite_Ancillary_Data_Info/Attitudes/Corrected_Attitudes/Values/AOCS_MODE	AOCS Mode	Standard
Satellite_Ancillary_Data_Info/Attitudes/Corrected_Attitudes/Values/AOCS_SUBMODE	AOCS submode	Standard
Satellite_Ancillary_Data_Info/Attitudes/Corrected_Attitudes/Values/INNOVATION_STR1	Difference Between GSE filter estimate and second in-use STR measurement	Standard
Satellite_Ancillary_Data_Info/Attitudes/Corrected_Attitudes/Values/INNOVATION_STR2	Difference Between GSE filter estimate and second in-use STR measurement	Standard
Satellite_Ancillary_Data_Info/Attitudes/Corrected_Attitudes/Values/ATTITUDE_QUALITY_INDICATOR	Attitude quality indicators	Standard
Satellite_Ancillary_Data_Info/Attitudes/Raw_Attitudes/STR_List/STR/Attitude_Data_List/Attitude_Data/QUATERNION_VALUES	Space separated list of 4 quaternion values ordered as (Q0 Q1 Q2 Q3) = (qv1 qv2 qv3 qs) (inertial attitude J2000).	Expertise
Satellite_Ancillary_Data_Info/Attitudes/Raw_Attitudes/STR_List/STR/Attitude_Data_List/Attitude_Data/ANGULAR_RATE	Angular rate (X, Y, Z) in BRF in deg/s	Expertise
Satellite_Ancillary_Data_Info/Attitudes/Raw_Attitudes/STR_List/STR/Attitude_Data_List/Attitude_Data/GPS_TIME	Time stamp of the center of integration associated with the attitude (with a precision up to 2pow-16 seconds). This field is computed from the centerOfIntegrationTimeStamp value provided in the data block	Expertise
Satellite_Ancillary_Data_Info/Attitudes/Raw_Attitudes/STR_List/STR/Attitude_Data_List/Attitude_Data/JULIAN_DATE	Julian date used for precession correction (if enabled); specified in number of days since the epoch date of the built-in star catalog; day 0 corresponds to JD 2451545	Expertise
Satellite_Ancillary_Data_Info/Attitudes/Raw_Attitudes/STR_List/STR/Attitude_Data_List/Attitude_Data/ATTITUDE_QUALITY_INDICATOR	Attitude Quality	Expertise
Satellite_Ancillary_Data_Info/Attitudes/Raw_Attitudes/STR_List/STR/Attitude_Data_List/Attitude_Data/RATE_QUALITY	Rate Quality	Expertise
Satellite_Ancillary_Data_Info/Attitudes/Raw_Attitudes/STR_List/STR/Attitude_Data_List/Attitude_Data/VALIDITY_RATE	if set to 1, the rate information is valid (i.e. derived from current measurements)	Expertise
Satellite_Ancillary_Data_Info/Attitudes/Raw_Attitudes/STR_List/STR/Attitude_Data_List/Attitude_Data/OPERATING_MODE	STR operating mode	Expertise





## Sentinel-2 Products Specification Document

REF : S2-PDGS-TAS-DI-PSD  
 ISSUE : 14.5  
 DATE : 14/03/2018  
 PAGE : 133 / 510

Satellite Ancillary Data Info		
Field Name	Description	Metatada Level
STR/Status_And_Health_Data_List/Status_And_Health_Data/O P_MODE		
Satellite_Ancillary_Data_Info/Attitudes/Raw_Attitudes/STR_List/ STR/Status_And_Health_Data_List/Status_And_Health_Data/TE C_MODE	Thermo electric cooler mode	Expertise
Satellite_Ancillary_Data_Info/Attitudes/Raw_Attitudes/STR_List/ STR/Status_And_Health_Data_List/Status_And_Health_Data/TA RGET	Target temperature for temperature control	Expertise
Satellite_Ancillary_Data_Info/Attitudes/Raw_Attitudes/STR_List/ STR/Status_And_Health_Data_List/Status_And_Health_Data/DE TECTOR	Detector temperature	Expertise
Satellite_Ancillary_Data_Info/Attitudes/Raw_Attitudes/STR_List/ STR/Status_And_Health_Data_List/Status_And_Health_Data/O PTICS	Optics temperature	Expertise
Satellite_Ancillary_Data_Info/Attitudes/Raw_Attitudes/STR_List/ STR/Status_And_Health_Data_List/Status_And_Health_Data/H OUSING	Housing temperature	Standard
Satellite_Ancillary_Data_Info/Attitudes/Raw_Attitudes/STR_List/ STR/Status_And_Health_Data_List/Status_And_Health_Data/SY NC_SOURCE	The source selected for external synchronization	Expertise
Satellite_Ancillary_Data_Info/Attitudes/Raw_Attitudes/STR_List/ STR/Status_And_Health_Data_List/Status_And_Health_Data/SE CONDS_SINCE_TIME_SYNC	The number of seconds since the latest received time synchronization; saturates at 63 seconds	Expertise
Satellite_Ancillary_Data_Info/Attitudes/Raw_Attitudes/STR_List/ STR/Status_And_Health_Data_List/Status_And_Health_Data/TR ACKABLE_STARS	Number of trackable stars	Expertise
Satellite_Ancillary_Data_Info/Attitudes/Raw_Attitudes/STR_List/ STR/Status_And_Health_Data_List/Status_And_Health_Data/TR ACKED_STARS	Number of stars tracked	Expertise
Satellite_Ancillary_Data_Info/Attitudes/Raw_Attitudes/STR_List/ STR/Status_And_Health_Data_List/Status_And_Health_Data/ID ENTIFIED_STARS	Number of identified stars	Expertise
Satellite_Ancillary_Data_Info/Attitudes/Raw_Attitudes/STR_List/ STR/Status_And_Health_Data_List/Status_And_Health_Data/US	Number of stars used for attitude determination	Expertise





## Sentinel-2 Products Specification Document

REF : S2-PDGS-TAS-DI-PSD  
 ISSUE : 14.5  
 DATE : 14/03/2018  
 PAGE : 134 / 510

Satellite_Ancillary_Data_Info		
Field Name	Description	Metatada Level
ED_STARS		
Satellite_Ancillary_Data_Info/Attitudes/Raw_Attitudes/STR_List/STR/Status_And_Health_Data_List/Status_And_Health_Data/ATT_RESULT	Last result of attitude determination	Expertise
Satellite_Ancillary_Data_Info/Attitudes/Raw_Attitudes/STR_List/STR/Status_And_Health_Data_List/Status_And_Health_Data/ID_RESULT	Last result of star identification error	Expertise
Satellite_Ancillary_Data_Info/Attitudes/Raw_Attitudes/IMU_List/IMU/Value/FILTERED_ANGLE	IMU filtered data are angle increments	Expertise
Satellite_Ancillary_Data_Info/Attitudes/Raw_Attitudes/IMU_List/IMU/Value/RAW_ANGLE	IMU raw data are angle increments	Expertise
Satellite_Ancillary_Data_Info/Attitudes/Raw_Attitudes/IMU_List/IMU/Value/GPS_TIME	GPS time value	Expertise
Satellite_Ancillary_Data_Info/Attitudes/Raw_Attitudes/IMU_List/IMU/Value/Temperatures/ORGANISER	Organiser temperature	Expertise
Satellite_Ancillary_Data_Info/Attitudes/Raw_Attitudes/IMU_List/IMU/Value/Temperatures/SIA	Sagnac Interferometer Assembly temperature	Expertise
Satellite_Ancillary_Data_Info/Attitudes/Raw_Attitudes/IMU_List/IMU/Value/Temperatures/OPTICAL_SOURCE	Optical Source temperature	Expertise
Satellite_Ancillary_Data_Info/Attitudes/Raw_Attitudes/IMU_List/IMU/Value/Temperatures/BOARD	Board temperature	Expertise
Satellite_Ancillary_Data_Info/Attitudes/Raw_Attitudes/IMU_List/IMU/Value/Temperatures/VOLTAGE_OFFSET	Temperature reference voltage offset	Expertise
Satellite_Ancillary_Data_Info/Attitudes/Raw_Attitudes/IMU_List/IMU/Value/Temperatures/VOLTAGE	Temperature reference voltage	Expertise
Satellite_Ancillary_Data_Info/Attitudes/Raw_Attitudes/IMU_List/IMU/Value/Temperatures/ACQUISITION	0:not acquired, 1:acq failed, 2:acquired	Expertise
Satellite_Ancillary_Data_Info/Attitudes/Raw_Attitudes/IMU_List/IMU/Value/Temperatures/VALIDITY	Acquisition validity flag	Expertise
Satellite_Ancillary_Data_Info/Attitudes/Raw_Attitudes/IMU_List/IMU/Value/Temperatures/TIME	Time corresponding to the measurements	Expertise
Satellite_Ancillary_Data_Info/Attitudes/Raw_Attitudes/IMU_List/IMU/Value/TIME	10PPS time corresponding to the measurements (provided by CSW)	Expertise





## Sentinel-2 Products Specification Document

REF : S2-PDGS-TAS-DI-PSD  
 ISSUE : 14.5  
 DATE : 14/03/2018  
 PAGE : 135 / 510

Satellite_Ancillary_Data_Info		
Field Name	Description	Metatada Level
Satellite_Ancillary_Data_Info/Attitudes/Raw_Attitudes/IMU_List/IMU/Value/ACQUISITION	0:not acquired, 1:acq failed, 2:acquired	Expertise
Satellite_Ancillary_Data_Info/Attitudes/Raw_Attitudes/IMU_List/IMU/Value/VALIDITY	Acquisition validity flag	Expertise
Satellite_Ancillary_Data_Info/Attitudes/Raw_Attitudes/IMU_List/IMU/Value/HEALTH_STATUS_BITS	16 Bits (0/1) sequence as defined in the IMU interface	Expertise
Satellite_Ancillary_Data_Info/Attitudes/Raw_Attitudes/IMU_List/IMU/Value/HEALTH_STATUS_BITS_VALIDITY	1 when all health status validity flag are ok(0)/ 0 otherwise	Expertise
Satellite_Ancillary_Data_Info/Thermal_Data/FPA_List/FPA/Value/T	FPA temperature information (thermal control and monitoring, relevant to the detector transmission VNIR or SWIR)	Expertise
Satellite_Ancillary_Data_Info/Thermal_Data/FPA_List/FPA/Value/GPS_TIME	Thermal Data info (Data acquired at 0.1 Hz)	Expertise
Satellite_Ancillary_Data_Info/Thermal_Data/FPA_List/FEE/Value/T	Thermal Data info (Data acquired at 0.1 Hz)	Expertise
Satellite_Ancillary_Data_Info/Thermal_Data/FPA_List/FEE/Value/GPS_TIME	Thermal Data info (Data acquired at 0.1 Hz)	Expertise
Satellite_Ancillary_Data_Info/Thermal_Data/Mirror_List/Mirror/Value/T	List of temperatures for each mirror	Expertise
Satellite_Ancillary_Data_Info/Thermal_Data/Mirror_List/Mirror/Value/GPS_TIME	Thermal Data info (Data acquired at 0.1 Hz)	Expertise
Satellite_Ancillary_Data_Info/Thermal_Data/ThSensor_List/ThSensor/Value/T	List of temperatures for each sensor on telescope	Expertise
Satellite_Ancillary_Data_Info/Thermal_Data/ThSensor_List/ThSensor/Value/GPS_TIME	Thermal Data info (Data acquired at 0.1 Hz)	Expertise
Satellite_Ancillary_Data_Info/Thermal_Data/Splitter_List/Value/T	List of temperatures for each splitter	Expertise
Satellite_Ancillary_Data_Info/Thermal_Data/SplitterList/Value/GPS_TIME	Thermal Data info (Data acquired at 0.1 Hz)	Expertise
Satellite_Ancillary_Data_Info/Thermal_Data/CSM_Diffuser_List/Value/T	List of temperatures for each diffuser	Expertise
Satellite_Ancillary_Data_Info/Thermal_Data/CSM_Diffuser_List/Value/GPS_TIME	Thermal Data info (Data acquired at 0.1 Hz)	Expertise
Satellite_Ancillary_Data_Info/Thermal_Data/IMU_Sensorplate_List/IMU_Sensorplate/Value/T	Imu sensor plate temperatures	Expertise





**Sentinel-2 Products  
Specification Document**

REF : S2-PDGS-TAS-DI-PSD  
ISSUE : 14.5  
DATE : 14/03/2018  
PAGE : 136 / 510

Satellite_Ancillary_Data_Info		
Field Name	Description	Metatada Level
Satellite_Ancillary_Data_Info/Thermal_Data/IMU_Sensorplate_List/IMU_Sensorplate/Value/GPS_TIME	Thermal Data info. (Data are acquired at 0.1 Hz)	Expertise
Satellite_Ancillary_Data_Info/Thermal_Data/STR_Sensorplate_List/STR_Sensorplate/Value/T	List of temperatures for each STR sensorplate	Expertise
Satellite_Ancillary_Data_Info/Thermal_Data/STR_Sensorplate_List/STR_Sensorplate/Value/GPS_TIME	Thermal Data info (Data acquired at 0.1 Hz)	Expertise
Satellite_Ancillary_Data_Info/Thermal_Data/STR_Baseplate_List/STR_Baseplate/Value/T	STR base plate temperatures	Expertise
Satellite_Ancillary_Data_Info/Thermal_Data/STR_Baseplate_List/STR_Baseplate/Value/GPS_TIME	Thermal Data info (Data acquired at 0.1 Hz)	Expertise
Satellite_Ancillary_Data_Info/Thermal_Data/STR_Backplate_List/STR_Backplate/Value/T	STR back plate temperatures.	Expertise
Satellite_Ancillary_Data_Info/Thermal_Data/STR_Backplate_List/STR_Backplate/Value/GPS_TIME	Thermal Data info (Data acquired at 0.1 Hz)	Expertise
Satellite_Ancillary_Data_Info/Lost_Source_Packet_List/Lost_Source_Packet/DEGRADATION_TYPE	Type of degradation	Standard
Satellite_Ancillary_Data_Info/Lost_Source_Packet_List/Lost_Source_Packet/ERROR_BEGINNING_DATE	error begin time	Standard
Satellite_Ancillary_Data_Info/Lost_Source_Packet_List/Lost_Source_Packet/ERROR_ENDING_DATE	error end time	Standard
Satellite_Ancillary_Data_Info/Lost_Source_Packet_List/Degradation_Summary Attribute: degradationPercentage	Percentage of lost or degraded packets for the Datatake	-
Satellite_Ancillary_Data_Info/Lost_Source_Packet_List/NUMBER_OF_LOST_PACKETS	number of lost packets for the whole Datatake	Standard
Satellite_Ancillary_Data_Info/Lost_Source_Packet_List/NUMBER_OF_DEGRADED_PACKETS	number of degraded packets for the whole Datatake	Standard
Satellite_Ancillary_Data_Info/ANC_DATA_REF	Reference to the folder (ANC_DATA) including the SAD raw data	Standard
Satellite_Ancillary_Data_Info/Other_Ancillary_Data/CSM_Flags_List/Values/INUSE_FLAG	Flag used to specify if the CSM information are useable or not	Expertise

Table 36: Level-0 Datastrip – Satellite\_Ancillary\_Data\_Info Description







**Sentinel-2 Products  
Specification Document**

REF : S2-PDGS-TAS-DI-PSD  
ISSUE : 14.5  
DATE : 14/03/2018  
PAGE : 137 / 510



Quality Indicators Info:

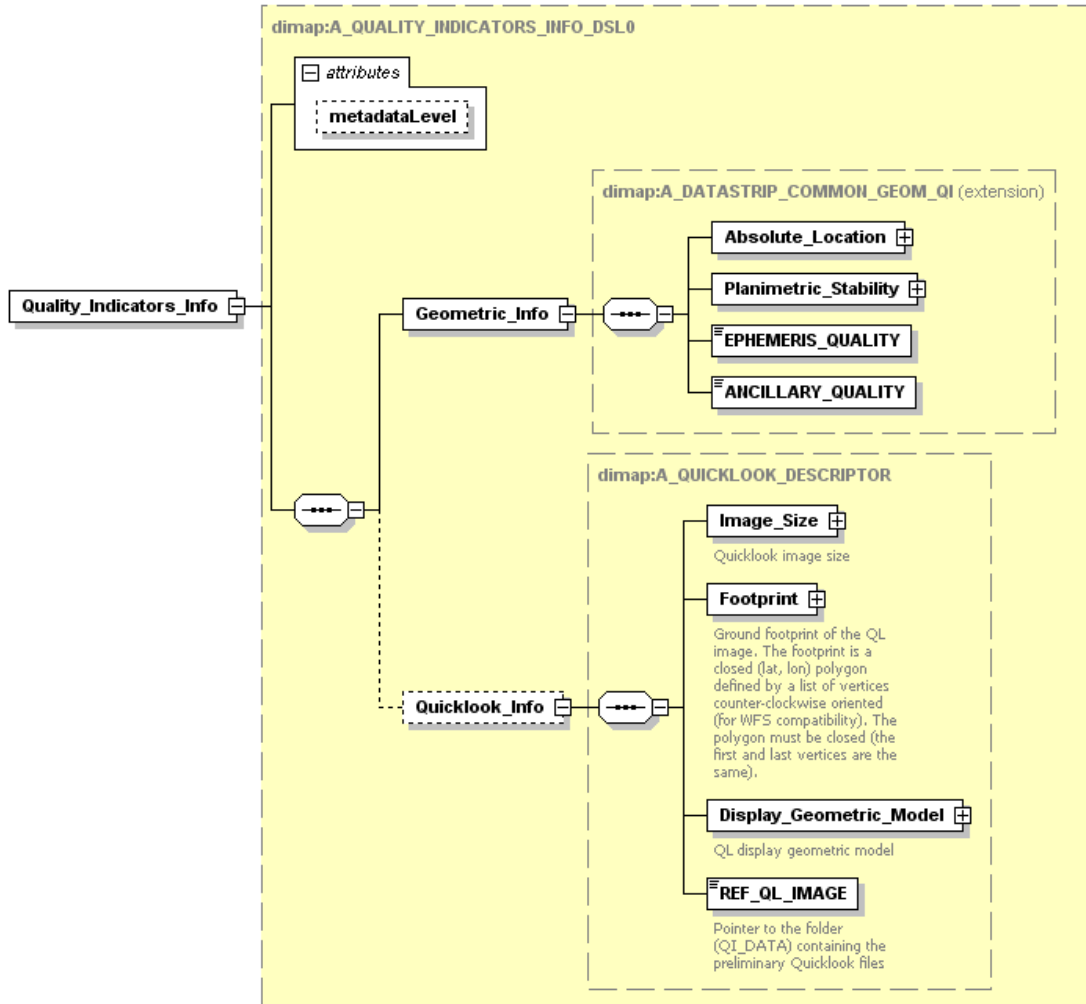

Figure 23 : Level-0 Datastrip – Quality\_Indicators\_Info Diagram



**Sentinel-2 Products  
Specification Document**

REF : S2-PDGS-TAS-DI-PSD  
 ISSUE : 14.5  
 DATE : 14/03/2018  
 PAGE : 139 / 510

Quality Indicators Info/Geometric Info		
Field Name	Description	Metatada Level
Absolute_Location	An absolute location performance for the Datastrip is given from a GIPP table, depending on the health status of the GPS and AOCS sensors (gyros and startrackers) provided in the Satellite Ancillary Data.	Brief
Planimetric_Stability	Planimetric stability assessment: A planimetric stability performance for the Datastrip is given from a GIPP table, depending on the health status of the GPS and AOCS sensors (gyros and startrackers) provided in the Satellite Ancillary Data	Brief
EPHEMERIS_QUALITY	Ephemeris data quality retrieved from GPS Dilution of precision (DOP) information	Brief
ANCILLARY_QUALITY	Ancillary data quality retrieved from GPS Dilution of precision (DOP) information.	Brief
Quality Indicators Info/Quicklook Info		
Field Name	Description	Metatada Level
Image_Size/NCOLS	Quicklook image size. Number of columns.	Brief
Image_Size/NROWS	Quicklook image size. Number of rows.	Brief
Footprint/EXT_POS_LIST	Ground footprint of the QL image. The footprint is a closed (lat, lon) polygon defined by a list of vertices counter-clockwise oriented (for WFS compatibility). The polygon must be closed (the first and last vertices are the same).  Point list. The coordinates of the points are entered as pairs of latitude and longitude values, or X and Y, or other	Brief
Footprint/INT_POS_LIST	Ground footprint of the QL image. The footprint is a closed (lat, lon) polygon defined by a list of vertices counter-clockwise oriented (for WFS compatibility). The polygon must be closed (the first and last vertices are the same).  Point list. The coordinates of the points are entered as pairs of latitude and longitude values, or X and Y, or other	Brief





**Sentinel-2 Products  
Specification Document**

REF : S2-PDGS-TAS-DI-PSD  
ISSUE : 14.5  
DATE : 14/03/2018  
PAGE : 140 / 510

Display_Geometric_Model/Datation_Model/L0	Line number of the first line	Brief
Display_Geometric_Model/Datation_Model/T0	Date of the first line	Brief
Display_Geometric_Model/Datation_Model/TE	Theoretical line period	Brief
Display_Geometric_Model/Viewing_Directions/NB_OF_PIXELS	Number of pixels	Brief
Display_Geometric_Model/Viewing_Directions/TAN_PSI_X_LIST	List of Tangent Psi X in the image order (there is one data by pixel)	Brief
Display_Geometric_Model/Viewing_Directions/TAN_PSI_Y_LIST	List of Tangent Psi Y in the image order (there is one data by pixel)	Brief
Display_Geometric_Model/Connect_col_List/CONNECT_COL	The 12 detectors are assembled and resampled in a monolithic quicklook image. This block gives, in the quicklook geometry, the connection columns number (last column) for each detectors (the first 11 detectors for compressed mode and 4 for uncompressed mode).	Brief
Display_Geometric_Model/Piloting_To_Msi_Frame/R1	First rotation (angles around an axis)	Brief
Display_Geometric_Model/Piloting_To_Msi_Frame/R2	Second rotation (angles around an axis)	Brief
Display_Geometric_Model/Piloting_To_Msi_Frame/R3	Third rotation (angles around an axis)	Brief
Display_Geometric_Model/Piloting_To_Msi_Frame/SCALE_FACTOR	A scale factor on Z axis (in order to model the focal length deformation)	Brief
Display_Geometric_Model/Piloting_To_Msi_Frame/COMBINATOR_ORDER	The combination order between rotation and scale factor transformations	Brief
REF_QL_IMAGE	Pointer to the folder (QI_DATA) containing the preliminary Quicklook image files	Brief

Table 37: Level-0 Datastrip – Quality\_Indicators\_Info Description



Auxiliary Data Info:

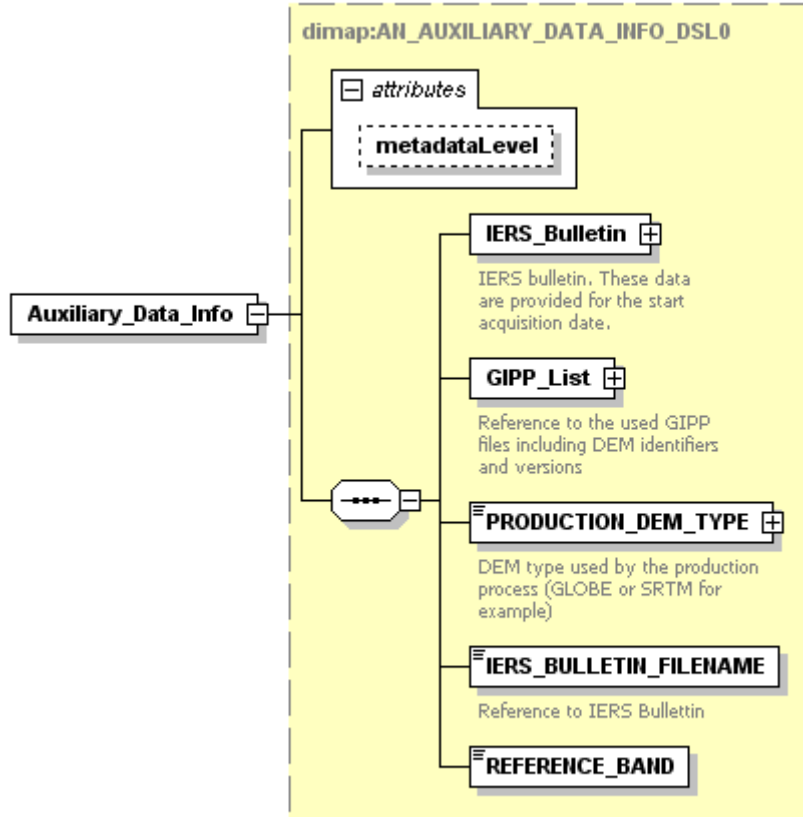

Generated by XMLSpy

www.altova.com

Figure 24 : Level-0 Datastrip – Auxiliary\_Data\_Info Diagram



**Sentinel-2 Products  
Specification Document**

REF : S2-PDGS-TAS-DI-PSD  
 ISSUE : 14.5  
 DATE : 14/03/2018  
 PAGE : 142 / 510

Auxiliary Data Info/IERS Bulletin		
Field Name	Description	Metatada Level
UT1.UTC	UT1 --UTC in [-0.9;0.9] seconds	Standard
GPS_TIME.UTC	GPS_time – UTC = in number of seconds	Standard
GPS_TIME.TAI	GPS_time – TAI	Standard
POLE_U.ANGLE	U angle pole motion (in arcsec)	Standard
POLE_V.ANGLE	V angle pole motion (in arcsec)	Standard
Auxiliary Data Info/GIPP List		
Field Name	Description	Metatada Level
GIPP.FILENAME	Reference to the used GIPP files.	Standard
PRODUCTION_DEM.TYPE	DEM type used by the production process (GLOBE or SRTM for example)	Standard
IERS_BULLETIN.FILENAME	Filename of the used IERS Bulletin	Standard
Auxiliary Data Info/REFERENCE_BAND		
Field Name	Description	Metatada Level
REFERENCE_BAND	Used reference band for datation	Standard

Table 38: Level-0 Datastrip – Auxiliary\_Data\_Info Description

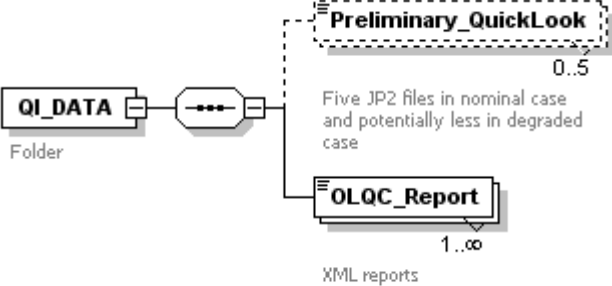

### 3.6.3.2 QI\_DATA

<p>diagram</p>	 <p>Generated by XMLSpy <a href="http://www.altova.com">www.altova.com</a></p>
<p>children</p>	<p><a href="#">Preliminary_QuickLook</a> <a href="#">OLQC_Report</a></p>
<p>annotation</p>	<p>QI_DATA folder contains:</p> <ul style="list-style-type: none"> <li>- XML reports generated by On-Line Quality Control processor, including Quality Control Checks results. The Annex C contains the description of OLQC reports.</li> <li>- preliminary QuickLook image files in sensor geometry (5 files in JP2 format in nominal case, less than 5 in degraded case).</li> </ul>

### 3.6.3.3 ANC\_DATA

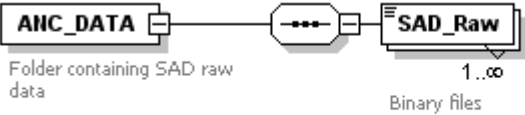
<p>diagram</p>	 <p>Folder containing SAD raw data</p> <p>Binary files</p> <p>1..∞</p> <p>Generated by XMLSpy <a href="http://www.altova.com">www.altova.com</a></p>
<p>children</p>	<p><a href="#">SAD_Raw</a></p>
<p>annotation</p>	<p>ANC_DATA folder contains:</p> <ul style="list-style-type: none"> <li>- SAD raw data as received from the DFEP.</li> </ul> <p>Note: SAD coverage is equal to the Datatake coverage only for the last Datastrip in a given Datatake. Otherwise, the SAD coverage is from the start of the Datatake (to which the Datastrip belongs to) to the stop of the Datastrip itself.</p>



### 3.6.4 SAFE Manifest synoptic table

This chapter provides a detailed description of the content of the SAFE Manifest for the Level-0 Datastrip PDI level.

The SAFE Manifest file is compliant to the SAFE specification (cf. [SAFE-SPEC]) and is composed (cf. section 3.4.4) by three main sections (Metadata, Information Package Map and Data Objects).

Part of the information contained in the Metadata section is extracted from the XML metadata file and is therefore duplicated in the SAFE Manifest and in the XML metadata file.

With reference to the three mentioned sections the chapter provides, as a guideline to the generation process of the SAFE Manifest file, the following elements:

- Table 31 describing the content and structure of the Information Package Map section; same consideration apply as in section 3.5.9;
- For the Metadata Section, a table that lists the fields (tags) composing the section, providing, for each field:
  - the field name in the SAFE Manifest file (column “SAFE Manifest”, divided into column “Metadata name”, containing the name of the Metadata section of the manifest to which the field belongs, and “Name of tag or attribute” containing the actual tag name or attribute name (for sake of clarity, attributes are written in bold characters))
  - the name of the corresponding tag (if available, else N.A.) of the XML Metadata File and of its XSD Schema (column “From S2\_PDI\_Level-0\_Datastrip\_Metadata.xsd”);
  - a brief textual description of the field;
  - the data type of the field (e.g. string, string enum, integer, double, xs:dateTime etc.);
  - the occurrence of the field (min/man occurrence e.g. 0..1); a minimum occurrence of 1 means that the field is mandatory;
  - the allowed range of values of the field.

In particular, the satellite ancillary data files (e.g. the SAD Raw Data file) and the auxiliary data files used for Level-0 processing (e.g. GIPP files, DEM, IERS Bulletin), are external to the product and are referenced in the Metadata of Manifest file Section (as “resources” in the “processing” section).

- Table 33 describing the content and structure of the Data Objects section; consider that this section contains a reference to each file (Data files and Metadata files) composing the Level-0 Datastrip PDI ( with the exception of the Manifest file itself); this includes:
  - the XML Metadata file;
  - the XML Inventory\_Metadata file;
  - a set of Quality Indicator Data Files, including a OLQC Report file (XML format) and five Preliminary Quick Look files (in JPEG2000 format).

An example of Manifest file for the Level-0 Datastrip PDI containing realistic, though indicative values, is provided as annexed zip file to this document (S2-PDGS-TAS-DI-PSD-V14\_SAFE.zip).

SAFE Manifest		From <i>S2_PDI_Level-0_Datastrip_Metadata.xsd</i>	Description	Data Type	Occurrence	Allowed range of values
Metadata name	Name of tag or attribute (in bold)	Tag name				
platform						
	nssdcIdentifier	N.A.	Unique identifier of the platform, defined by the World Data center for Satellite Information (WDC-SI)		1	WDC is discontinued; this tag is set to a default value 0000-0000
	familyName	General_Info->Datatake_Info->SPACECRAFT_NAME	The mission name of the platform	string enum	0..1	Sentinel
	number	General_Info->Datatake_Info->SPACECRAFT_NAME	Sequence identifier of the platform among the mission	string enum	0..1	2A, 2B, 2C
	instrument->familyName	N.A.	The instrument name used for acquiring the product data	string enum	0..1	Multi-Spectral Instrument
	instrument-> <b>abbreviation</b>	N.A.	Abbreviation of the instrument name	string enum	0..1	MSI
	instrument->mode	N.A.	The mode of the instrument	string enum	0..1	Nominal_Observation Dark_Signal_Calibration

SAFE Manifest		From <i>S2_PDI_Level-0_Datastrip_Metadata.xsd</i>	Description	Data Type	Occurrence	Allowed range of values
Metadata name	Name of tag or attribute (in bold)	Tag name				
						Extended_Observation Absolute_Radiometry_Calibration Vicarious_Calibration Raw_Measurement Test_Mode
	Instrument->mode-> <b>identifier</b>	General_Info->Datatake_Info->DATATAKE_TYPE	The identifier of the instrument mode	string enum	1	INS-NOBS INS-EOBS INS-DASC INS-ABSR INS-VIC INS-RAW INS-TST
processing			Textual description of the history of processings that lead to the current product and of all the relevant resources involved in the processing (facilities, software, applicable documents etc)		1	
	<b>name</b>	N.A.	Name of the Archiving process	string	0..1	Archiving of PDI Level-0 Granule Product
	<b>start</b>	General_Info->Archiving_Info->ARCHIVING_TIME	Archiving start date (UTC)	xs:dateTime	0..1	
	facility		Description of Origin Centre		0..*	
	facility-> <b>name</b>	N.A.	Extended name of Origin Centre	string	1	
	facility-> <b>organization</b>	N.A.	Organization to which the Origin center belongs	string	0..1	

SAFE Manifest		From <i>S2_PDI_Level-0_Datastrip_Metadata.xsd</i>	Description	Data Type	Occurrence	Allowed range of values
Metadata name	Name of tag or attribute (in bold)	Tag name				
	facility-> <b>site</b>	General_Info->Archiving_Info->ARCHIVING_CENTRE	The starting point of the circulation data	string enum	0..1	SGS_ MPS_ MTI_ EPA_ UPA_ CDAM MPC_
	facility-> <b>country</b>	N.A.	Country where Origin Centre is located	string	0..1	
	resource		Description of product being archived		0..*	
	resource-> <b>name</b>	N.A.	Name of the product being archived	string	1	
	resource-> <b>role</b>	N.A.	Role of the resource	string	1	PDI Level-0 Datastrip Product
	resource-> processing		Description of the L0 Processing		0..*	
	resource-> processing-> <b>name</b>		Name of the L0 Processing	string	0..1	L0 Processing of Raw Data
	resource-> processing-> <b>start</b>	General_Info->Processing_Info->UTC_DATE_TIME	Processing start date (UTC)	xs:dateTime	0..1	
	resource-> processing-> facility	N.A.	Description of Processing Centre		0..*	
	resource-> processing-> facility-> <b>name</b>	N.A.	Extended name of Origin Centre	string	1	
	resource-> processing-> facility-> <b>organization</b>	N.A.	Organization to which the Origin center belongs	string	0..1	

SAFE Manifest		From <i>S2_PDI_Level-0_Datastrip_Metadata.xsd</i>	Description	Data Type	Occurrence	Allowed range of values
Metadata name	Name of tag or attribute (in bold)	Tag name				
	resource-> processing-> facility-> <b>site</b>	General_Info->Processing_Info-> PROCESSING_CENTER	Acronym of the Processing center	string enum	0..1	SGS_ MPS_ MTI_ EPA_ MPC_ UPA_ XXXX EDRS zzzL (zzz = first three characters of the LGS location)
	resource-> processing-> facility-> <b>country</b>	N.A.	Country where Origin Centre is located	string	0..1	
	resource-> processing-> facility-> software	N.A.	Description of software component used for Processing		0..*	
	resource-> processing-> facility-> resource		List of auxiliary data files used by the processors to support radiometric and geometric correction (GIPP, DEM, GRI, IERS Bulletin etc) and of SAD Raw Data file containing the satellite ancillary telemetry; these files are not provided with the product.		0..*	
	resource-> processing-> facility-> resource-> <b>name</b>	Satellite_Ancillary_Data_Info-> ANC_DATA_REF (reference to the folder containing the SAD Raw Data files)  Auxiliary_Data_Info->IERS_Bulletin	Absolute path name of the auxiliary or ancillary file/folder	string	1	



**Sentinel-2 Products  
Specification Document**

REF : S2-PDGS-TAS-DI-PSD  
ISSUE : 14.5  
DATE : 14/03/2018  
PAGE : 150 / 510

SAFE Manifest		From <i>S2_PDI_Level-0_Datastrip_Metadata.xsd</i>	Description	Data Type	Occurrence	Allowed range of values
Metadata name	Name of tag or attribute (in bold)	Tag name				
		Auxiliary_Data_Info->GIPP_List->GIPP_FILENAME				
	resource-> processing-> facility->resource-> <b>role</b>	N.A.	Role of the resource	string	1	Auxiliary data, Ancillary data
acquisitionPeriod					1	
	acquisitionPeriod ->startTime	Datastrip->L0_Datastrip_PDI_ID (substring <Sensing Time>, cf. section 3.5.6)	Reference time of acquisition of the Granule (corresponding to sensing time of the first line of the PDI at Datastrip level, cf. section 3.5.6)	xs:dateTime	1	
measurementOrbitReference						
	orbitNumber	General_Info->Datatake_Info->DatatakeIdentifier (substring <AbsoluteOrbitNumber>)	Absolute orbit number		0..1	> 0
	orbitNumber-> <b>type</b>	N.A.	Absolute orbit number type (possible values "start" or "stop"). Set to "start" since the absolute orbit number refers to the first line of the Datastrip		0..1	start
	orbitNumber-> <b>groundTrackDirection</b>	General_Info->Datatake_Info->SENSING_ORBIT_DIRECTION	Direction of the ground track of the Sentinel-2 platform at the time corresponding to orbitNumber->type (start or stop)		0..1	ascending, descending



SAFE Manifest		From <i>S2_PDI_Level-0_Datastrip_Metadata.xsd</i>	Description	Data Type	Occurrence	Allowed range of values
Metadata name	Name of tag or attribute (in bold)	Tag name				
	relativeOrbitNumber	General_Info->Datatake_Info->SENSING_ORBIT_NUMBER	Relative orbit number (within the cycle)		0..1	1 to 143
	relativeOrbitNumber-> <b>type</b>	N.A.	Relative orbit number type (possible values "start" or "stop"). Set to "start" since the absolute orbit number refers to the first line of the Datastrip		0..1	start
metadataComponents		N.A.	A reference to all Metadata files included in the product (e.g. the XML Metadata file, the XML Inventory Metadata file)		2..4	
metadataComponentSchemas		N.A.	A reference to the Schemas used to validate the Metadata files included in the product (e.g. the XML Metadata file Schema)		0..2	

Table 39 - Content of Metadata Section for PDI Level-0 Datastrip SAFE Manifest

### 3.7 Level-1A Granule PDI definition

Level-1A Granule PDI level is defined as a **tar** file with the following structure:

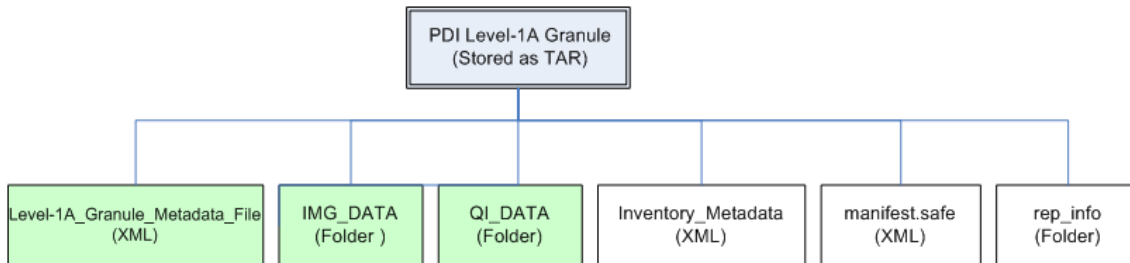

Figure 25: PDI Level-1A Granule Structure

The PDI Level-1A Granule consists of:

1. **Level-1A\_Granule\_Metadata\_File**: XML metadata file containing the requested level of information and referring all the product elements composing the Granule,
2. **IMG\_DATA**: folder containing image data compressed using the JPEG2000 algorithm, one file per spectral band.
3. **QI\_DATA**: folder containing XML reports including Quality control checks and Quality Mask files;
4. **Inventory\_Metadata.xml**: file containing the metadata needed to inventory the PDI;
5. **manifest.safe**: XML SAFE Manifest file (mandatory, cf. section 3.7.4);
6. **rep\_info**: folder containing the available XSD schemas that validate the PDI components (recommended by [SAFE-SPEC], cf. section 3.4.4)

#### 3.7.1 PDI\_ID definition

The PDI\_ID (Granule ID) used to identify a Level-1A Granule PDI, follows the description provided in the section 3.4.2. File\_Type is defined in the section 3.2, Table 5.

Level-1A Granule template Name (Granule ID):

*S2A\_OPER\_MSI\_L1A\_GR\_MTI\_\_20141104T134012\_S20141104T134012\_D03\_N01.12.tar*

Note that the PDI\_ID.tar is the physical name of the Granule PDI after the tar compression.



### 3.7.2 Level-1A Granule Physical Format

The PDI ID defined above represents the “Granule directory” name. Inside the Granule directory, there are the Granule components as in the Figure 25.

Inside that directory, the naming convention used to identify each real file follows the same convention used to define the Granule ID but without the Processing Baseline sub-string.

- **Level-1A\_Granule\_Metadata\_File (XML file):**

Granule Metadata File Template name:

*S2A\_OPER\_MTD\_L1A\_GR\_MTI\_\_20141104T134012\_S20141104T134012\_D03.xml*

The XSD schema, which regulates the metadata file, is *S2\_PDI\_Level-*

*1A\_Granule\_Metadata.xsd* included in the *S2-PDGS-TAS-DI-PSD-V14\_Schemas.zip* file annexed to the document.

- **IMG\_DATA (folder):**

The naming convention used to identify the image files contained in the IMG\_DATA folder is defined hereafter:

Image File naming convention = *<PDI\_ID\*>\_<Band\_Index>.jp2*

where:

Field Name	Value/Meaning	Note
<i>PDI_ID*</i>	PDI_ID without Processing Baseline sub-string	
<i>Band Index</i>	Bxx where: xx = 01, 02, 03, 04, 05, 06, 07, 08, 8A, 09, 10, 11, 12	Field identifying the spectral bands

IMG\_DATA/Level-1A image file template name:

*S2A\_OPER\_MSI\_L1A\_GR\_MTI\_\_20141104T134012\_S20141104T134012\_D03\_B03.jp2*

- **QI\_DATA (folder):**

QI\_DATA folder contains:

- XML reports *OLQC\_Report.xml* generated by On-Line Quality Control processor, including Quality Control Checks results. The *OLQC\_Report.xsd* schema and the reports naming convention are in the Annex C of the document.

File Template Name:

*S2A\_OPER\_MSI\_L1A\_GR\_MTI\_\_20141104T134012\_S20141104T134012\_D03\_GEOMETRIC\_QUALITY\_report.xml*

- Quality\_Masks (one for each type, GML/JPEG2000).

The naming used for the mask files follows the same convention defined for the L1A Granule ID (cf. section 3.4.2) except for the additional *<Product Type>* filed.

Mask files naming convention = MMM\_CCCC\_TTTTTTTTTT\_<Instance\_ID>.gml

L1A masks main file types (TTTTTTTTTT) are in the Table 18 and listed again hereafter

1. MSK\_CLOLOW (Coarse cloud mask files)
2. MSK\_TECQUA (Technical quality mask files)
3. MSK\_DEFECT (Radiometric quality masks)
4. MSK\_SATURA (Radiometric quality masks)
5. MSK\_NODATA (Radiometric quality masks)

<Instance\_Id> = <Site Centre>\_<Creation Date>\_<Sensing Time>\_<Detector ID>\_<Band ID>\_<Product\_Type>

Where <Site Centre>, <Creation Date>, <Sensing Time> and <Detector ID> are inherited from the L1A Granule ID, <Product Tipe> = "MSIL1A" and <Band ID>:

<i>Band ID</i>	Bxx where:  xx = 01, 02, 03, 04, 05, 06, 07, 08, 8A, 09, 10, 11, 12
----------------	---





Template masks filename are:

S2A\_OPER\_MSK\_TECQUA\_MTI\_\_20141104T134012\_S20141104T134012\_D03\_B03\_MSIL1A.gml  
 S2A\_OPER\_MSK\_SATURA\_MTI\_\_20141104T134012\_S20141104T134012\_D03\_B03\_MSIL1A.gml

The grouping strategy to have several masks in one physical GML file is described in the Annex E.

- **Inventory\_Metadata (XML file):**  
XML Inventory metadata file with fixed name *Inventory\_Metadata.xml*
- **manifest.safe (XML file):**  
XML file with fixed name *manifest.safe*
- **rep\_info (folder):**  
Folder containing the following XSD schemas:
  1. *S2\_PDI\_Level-1A\_Granule\_Metadata.xsd*
  2. *Inventory\_Metadata.xsd*
  3. *OLQC\_Report.xsd*

Level-1A Granule Physical Format template:

Level-1A Granule PDI_ID: S2A_OPER_MSI_L1A_GR_MTI__20141104T134012_S20141104T134012_D03_N01.12
 <i>Inventory_Metadata.xml</i>  S2A_OPER_MTD_L1A_GR_MTI__20141104T134012_S20141104T134012_D03.xml  <i>manifest.safe</i>  IMG_DATA

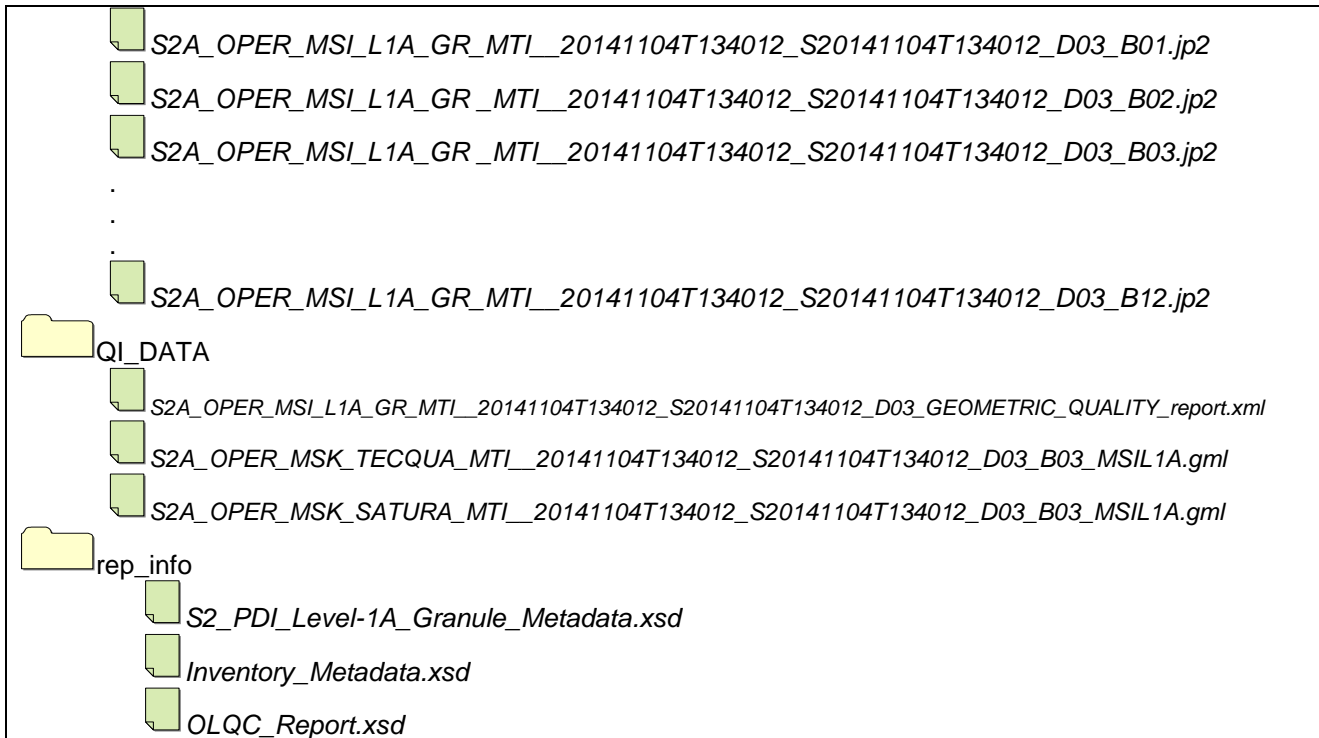
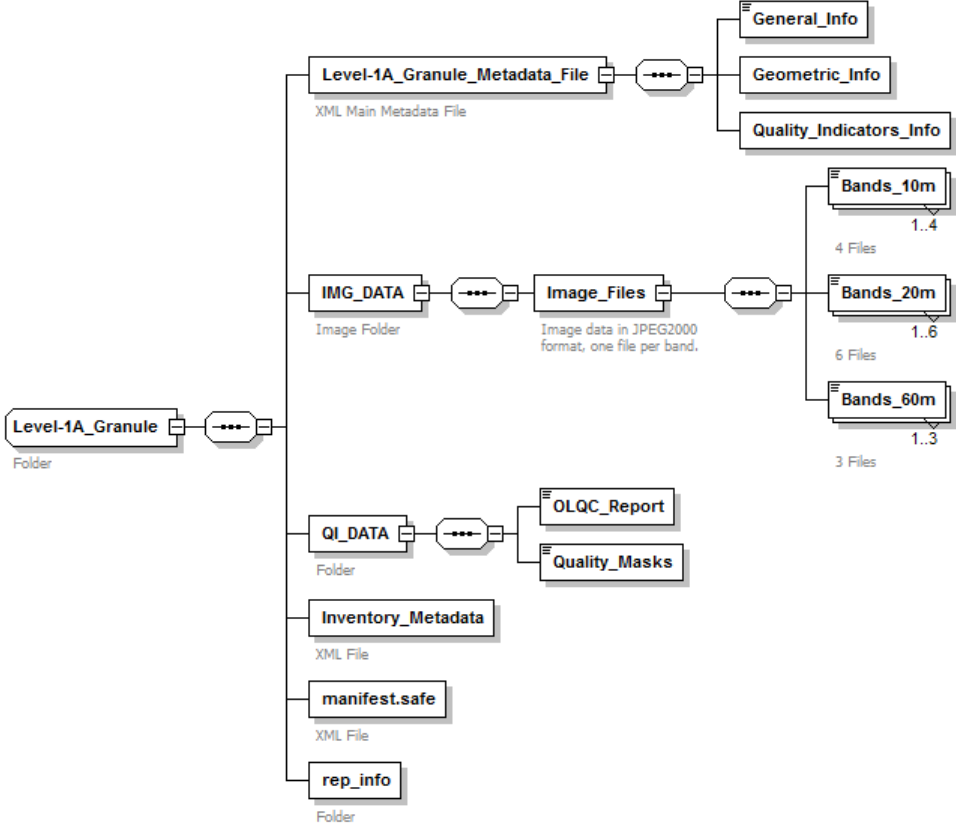

Figure 26: PDI Level-1A Granule Physical Format

### 3.7.3 Level-1A Granule PDI Structure

The *S2\_PDI\_Level-1A\_Granule\_Structure.xsd* schema annexed to the document and shown in the following diagram, represents the organization of a Level-1A Granule PDI on disk. This schema is provided for information only as It is actually not expected to be used for the validation of a XML file. The diagram reflects exactly the Figure 25.

<p>diagram</p>	 <p align="center">Generated by XMLSpy <span style="float:right">www.altova.com</span></p>
<p>children</p>	<p><a href="#">Level-1A_Granule_Metadata_File</a> <a href="#">IMG_DATA</a> <a href="#">QI_DATA</a> <a href="#">Inventory_Metadata</a> <a href="#">manifest.safe</a> <a href="#">rep_info</a></p>
<p>annotation</p>	<p>The Level-1A Granule is defined as a folder containing:</p> <ol style="list-style-type: none"> <li>1. <b>Level-1A_Granule_Metadata_File</b>: XML main metadata file.</li> <li>2. <b>IMG_DATA</b>: Folder containing Image data in JPEG2000 format, one file per band.</li> <li>3. <b>QI_DATA</b>: Folder containing XML reports including Quality Indicators and GML Quality Mask files</li> <li>7. <b>Inventory_Metadata</b>: XML inventory metadata file</li> <li>8. <b>manifest.safe</b>: XML SAFE Manifest file</li> <li>9. <b>rep_info</b>: folder containing the XSD schemas provided inside a SAFE Level-1A Granule PDI</li> </ol> <p><u>Note that the Inventory_Metadata.xml, manifest.safe and rep_info are removed when the PDI is included in the User Product.</u></p>



**Sentinel-2 Products  
Specification Document**

REF : S2-PDGS-TAS-DI-PSD  
ISSUE : 14.5  
DATE : 14/03/2018  
PAGE : 157 / 510



### 3.7.3.1 Level-1A\_Granule\_Metadata\_File Schema

Level-1A\_Granule\_Metadata\_File is the XML metadata file provided inside each Level-1A Granule. The schema used to validate it is *S2\_PDI\_Level-1A\_Granule\_Metadata.xsd* annexed to this document. A detailed description of the schema is given here but for specific details regarding each metadata (e.g. type, default value, fixed value, enumerations, occurrences, etc...) refers to the XSD file.

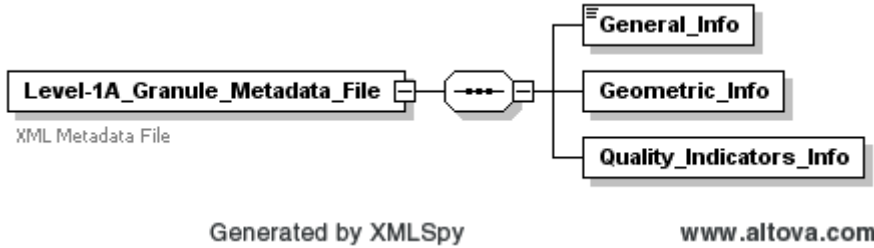
diagram	
children	<a href="#">General_Info</a> <a href="#">Geometric_Info</a> <a href="#">Quality_Indicators_Info</a>
annotation	<p>The Level-1A_Granule_Metadata_File is an XML file containing metadata regarding:</p> <ol style="list-style-type: none"> <li>1. <b>General_Info</b>: this group of metadata provides general information regarding the Granule.</li> <li>2. <b>Geometric_Info</b>: these metadata provide information describing the geolocation of the Granule.</li> <li>3. <b>Quality_Indicators_Info</b>: this metadata values provide information about image content quality indicators and quality control checks information.</li> </ol>

The following figures and tables give a complete overview of the Level-1A\_Granule\_Metadata\_File [schema](#) according the description provided in the section 3.4.1.

General Info:

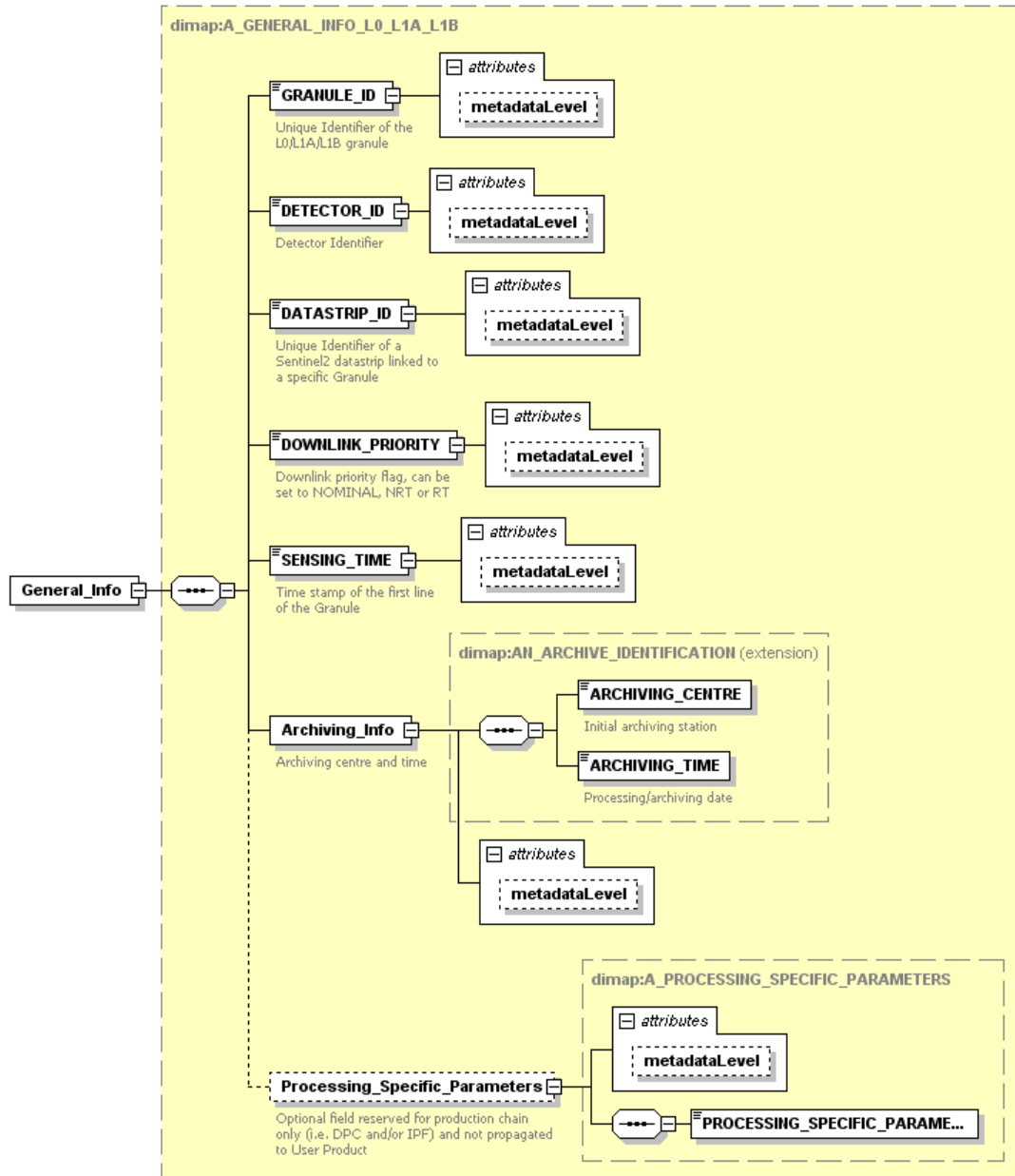

Generated by XMLSpy

www.altova.com

Figure 27: Level-1A\_Granule\_Metadata\_File - General\_Info Diagram



**Sentinel-2 Products  
Specification Document**

REF : S2-PDGS-TAS-DI-PSD  
ISSUE : 14.5  
DATE : 14/03/2018  
PAGE : 160 / 510

General Info		
Field Name	Description	Metatada Level
GRANULE_ID	Granule_Identifier metadata indicates the unique identifier of the Level-1A Granule. This parameter coincides with PDI_ID definition described in section 3.5.6 and univocally points a Granule PDI in the archive.	Brief
DETECTOR_ID	Detector identifier corresponding to the Granule	Brief
DATASTRIP_ID	Unique identifier of the L1A Datastrip PDI linked to L1A Granule PDI. This parameter coincides with the PDI_ID of the PDI Datastrip linked to the Granule. This link establishes the hierarchy Granule vs Datastrip (cf. section 3.3)	Brief
DOWNLINK_PRIORITY	Downlink priority flag. It can be set Nominal/NRT/RT.	Standard
SENSING_TIME	Time stamp of the first line of the Granule that is the Sensing Start Time of the Granule PDI.  Note: for L1A Granule the first line timing shall be taken from one reference band due to the coarse registration applied at Level 1A, which makes the first line time different amongst the bands.	Standard
Archiving_Info/ARCHIVING_CENTRE	The allowed values are: <ul style="list-style-type: none"> <li>• SGS_</li> <li>• MPS_</li> <li>• MTI_</li> <li>• EPA_</li> <li>• UPA_</li> <li>• CDAM</li> <li>• MPC_</li> </ul>	Expertise
Archiving_Info/ARCHIVING_TIME	Processing/archiving date (UTC data time)	Expertise
Processing_Specific_Parameters/ PROCESSING_SPECIFIC_PARAMETERS	Optional field reserved for production chain only (NOT propagated to User Product)	Expertise

Table 40: Level-1A\_Granule\_Metadata\_File - General\_Info Description





Geometric Info:

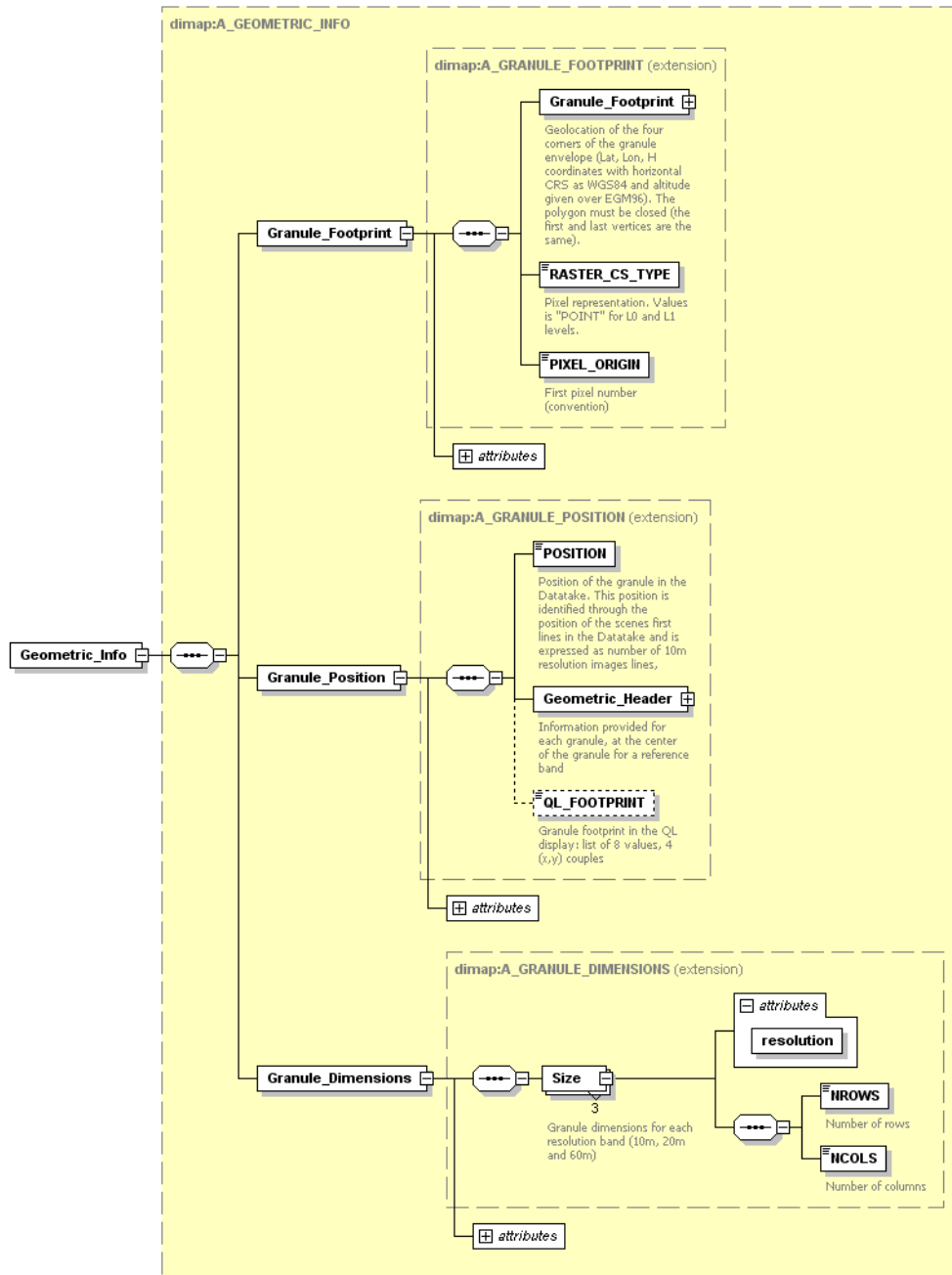

Generated by XMLSpy

www.altova.com

Figure 28: Level-1A\_Granule\_Metadata\_File - Geometric\_Info Diagram



**Sentinel-2 Products  
Specification Document**

REF : S2-PDGS-TAS-DI-PSD  
 ISSUE : 14.5  
 DATE : 14/03/2018  
 PAGE : 162 / 510

<b>Geometric_Info/Granule_Footprint</b>		
<b>Field Name</b>	<b>Description</b>	<b>Metatada Level</b>
Granule_Footprint	Geolocation of the four corners of the Granule envelope (Lat, Lon, H coordinates with horizontal CRS as WGS84 and altitude given over EGM96).	Brief
RASTER_CS_TYPE	Pixel representation. Values is "POINT" for L0 and L1 levels.	Brief
PIXEL_ORIGIN	First pixel number (convention)	Brief
<b>Geometric_Info/Granule_Position</b>		
<b>Field Name</b>	<b>Description</b>	<b>Metatada Level</b>
Position	Granule_Position describes the position of the Granule in the origin Datatake. This position is identified through the position of the scenes first lines in the Datatake and is expressed as number of 10m resolution images lines). Moreover information for a reference band at the centre of the Granule (incidence angles and solar angles) are provided.	Standard
Geometric_Header/GROUND_CENTER	Information provided for a reference band, at the centre of the Granule, for each Granule. Geolocation of the Granule centre (Lat, Lon, H) Altitude is provided over the geoid.	Standard
Geometric_Header/QL_CENTER	The Granule centre in the QL display: 1 (r,c) point.	Standard
Geometric_Header/Incidence_Angles	Information provided for a reference band, at the centre of the Granule, for each Granule. Incidence angles corresponding to the centre of the Granule.	Standard
Geometric_Header/Solar_Angles	Information provided for a reference band, at	Standard



	the centre of the Granule, for each Granule. Solar angles corresponding to the centre of the Granule.	
QL_FOOTPRINT	Granule footprint in the QL display: list of 8 values, 4 (x,y) couples.  Note: For L1A Granule this metadata is NOT mandatory.	Standard
<b>Geometric_Info/Granule_Dimension</b>		
<b>Field Name</b>	<b>Description</b>	<b>Metatada Level</b>
Size/NROWS	Granule dimensions provided for each resolution band (10m, 20m and 60m)  Number of Row	Standard
Size/NCOLS	Granule dimensions provided for each resolution band (10m, 20m and 60m)  Number of Columns	Standard

Table 41: Level-1A\_Granule\_Metadata\_File - Geometric\_Info Description

Quality Indicators Info:

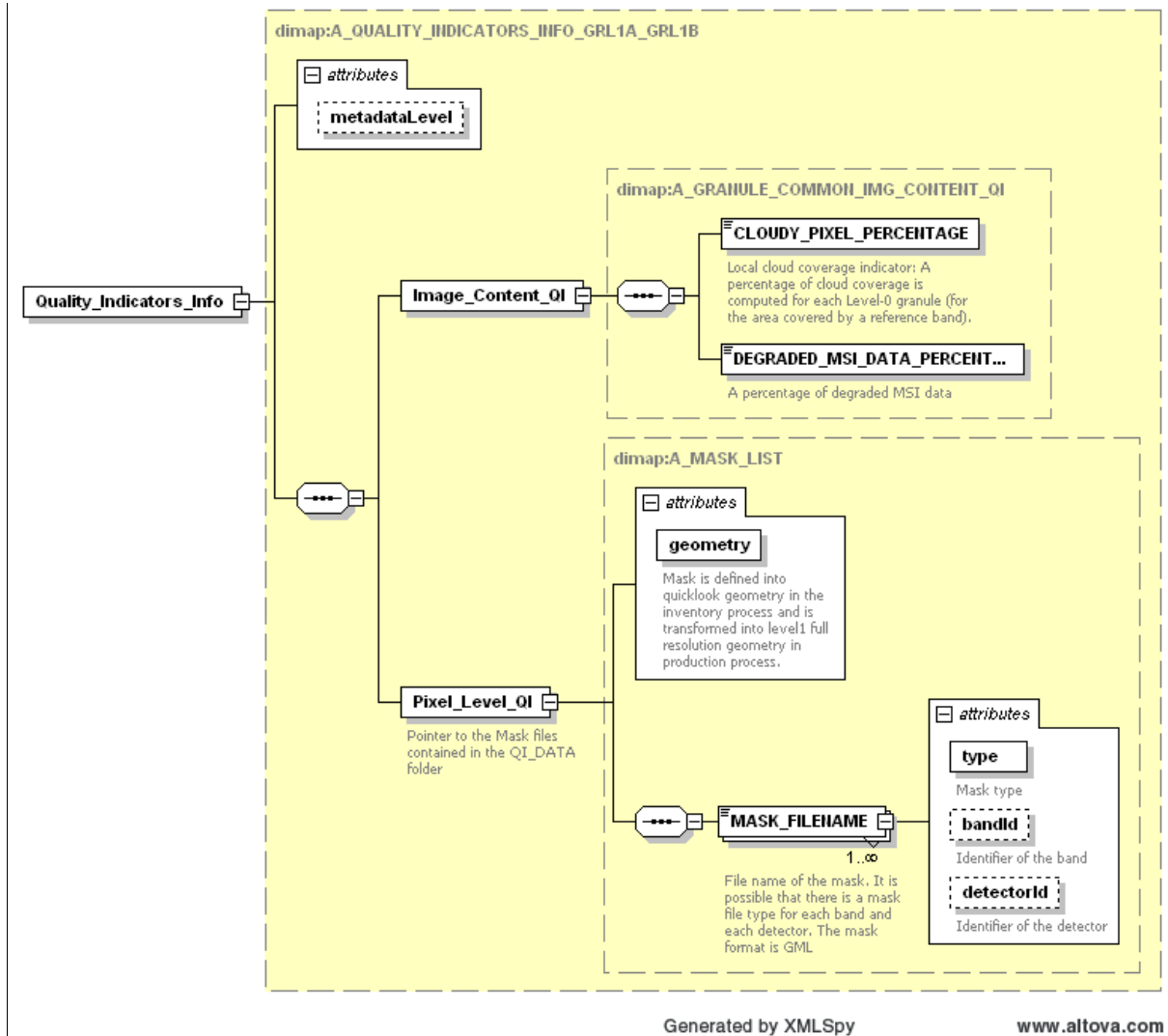

Figure 29: Level-1A\_Granule\_Metadadata\_File – Quality\_Indicators\_Info Diagram

According to the content of the Table 3-4, the following table describes the Quality Indicators provided for a Level-1A Granule PDI.

<b>Quality_Indicators_Info/Image_Content_QI</b>		
<b>Field Name</b>	<b>Description</b>	<b>Metatada Level</b>
CLOUDY_PIXEL_PERCENTAGE	Local cloud coverage indicator: A percentage of cloud coverage is computed for each Level-1A Granule (for the area covered by a reference band).	Standard
DEGRADED_MSI_DATA_PERCENTAGE	Local technical quality indicator: A percentage of degraded MSI data is provided for each Level-1A Granule.	Standard
<b>Quality_Indicators_Info/Pixel_Level_QI</b>		
<b>Field Name</b>	<b>Description</b>	<b>Metatada Level</b>
MASK_FILENAME	Pointer to the mask files contained in the QI_DATA folder: <ul style="list-style-type: none"> <li>- Coarse cloud mask files</li> <li>- Technical quality mask files</li> <li>- Radiometric quality masks</li> </ul>	Standard

Table 42: Level-1A\_Granule\_Metadata\_File – Quality\_Indicators\_Info Description

Note that, according to OLQC procedures consolidation, the results of all quality control checks performed by OLQC processor on Level-1A Granule, are included in the XML reports stored in the QI\_DATA folder (cf. § 3.4.1, Table 19).

### 3.7.3.2 IMG\_DATA

diagram	<p>Generated by XMLSpy <span style="float: right;">www.altova.com</span></p>
children	<a href="#">Image_Files</a>
annotation	Folder containing image data compressed using the JPEG2000 algorithm, one file per spectral band (13 files).

### 3.7.3.3 QI\_DATA

diagram	<p>Generated by XMLSpy <span style="float: right;">www.altova.com</span></p>
children	<a href="#">OLQC_Report</a> <a href="#">Quality_Masks</a>
annotation	QI_DATA folder contains the XML reports including the quality control checks performed by OLQC processor and the GML quality masks. The Annex C contains the description of OLQC reports, the masks files are listed in the Table 18 .

### 3.7.4 SAFE Manifest synoptic table

This chapter provides a detailed description of the content of the SAFE Manifest for the Level-1A Granule PDI level.

The SAFE Manifest file is compliant to the SAFE specification (cf. [SAFE-SPEC]) and is composed (cf. section 3.4.4) by three main sections (Metadata, Information Package Map and Data Objects).

Part of the information contained in the Metadata section is extracted from the XML metadata file and is therefore duplicated in the SAFE Manifest and in the XML metadata file.

With reference to the three mentioned sections the chapter provides, as a guideline to the generation process of the SAFE Manifest file, the following elements:

- Table 31 describing the content and structure of the Information Package Map section; same consideration apply as in section 3.5.9;
- for the Metadata Section, a table that lists the fields (tags) composing the section, providing, for each field:
  - the field name in the SAFE Manifest file (column “SAFE Manifest”, divided into column “Metadata name”, containing the name of the Metadata section of the manifest to which the field belongs, and “Name of tag or attribute” containing the actual tag name or attribute name (for sake of clarity, attributes are written in bold characters))
  - the name of the corresponding tag (if available, else N.A.) of the XML Metadata File and of its XSD Schema (column “From S2\_PDI\_Level-1A\_Granule\_Metadata.xsd”);
  - a brief textual description of the field;
  - the data type of the field (e.g. string, string enum, integer, double, xs:dateTime etc.);
  - the occurrence of the field (min/man occurrence e.g. 0..1); a minimum occurrence of 1 means that the field is mandatory;
  - the allowed range of values of the field.
- Table 33 describing the content and structure of the Data Objects section; consider that this section contains a reference to each file (Data files and Metadata files) composing the Level-1A Granule PDI (with the exception of the Manifest file itself); this includes:
  - the XML Granule Metadata file;
  - the Inventory\_Metadata.xml file;
  - a set of image files in JPEG2000 format (one file per spectral band, up to a total of 13 files);
  - a set of Quality Indicator Data Files, including a OLQC Report file and one or more pixel-level Quality Mask files.

An example of Manifest file for the Level-1A Granule PDI containing realistic, though indicative values, is provided as annexed zip file to this document (S2-PDGS-TAS-DI-PSD-V14\_SAFE.zip).

SAFE Manifest		From S2_PDI_Level-1A_Granule_Metadata.xsd	Description	Data Type	Occurrence	Allowed range of values
Metadata name	Name of tag or attribute (in bold)	Tag name				
platform						
	nssdcIdentifier	N.A.	Unique identifier of the platform, defined by the World Data center for Satellite Information (WDC-SI)		1	WDC is discontinued; this tag is set to a default value 0000-0000
	familyName	General_Info->GRANULE_ID (substring <Mission ID>, cf. section 3.5.6)	The mission name of the platform		0..1	Sentinel
	number	General_Info->GRANULE_ID (substring <Mission ID>, cf. section 3.5.6)	Sequence identifier of the platform among the mission	string enum	0..1	2A, 2B, 2C
	instrument->familyName	N.A.	The instrument name used for acquiring the product data	string enum	0..1	Multi-Spectral Instrument
	instrument-> <b>abbreviation</b>	N.A.	Abbreviation of the instrument name	string enum	0..1	MSI
	instrument->mode	N.A.	The mode of the instrument	string enum	0..1	Nominal_Observation Dark_Signal_Calibration Extended_Observation Absolute_Radiometry_Calibration Vicarious_Calibration Raw_Measurement Test_Mode



SAFE Manifest		From S2_PDI_Level-1A_Granule_Metadata.xsd	Description	Data Type	Occurrence	Allowed range of values
Metadata name	Name of tag or attribute (in bold)	Tag name				
	Instrument->mode-> <b>identifier</b>	N.A.	The identifier of the instrument mode	string enum	1	INS-NOBS INS-EOBS INS-DASC INS-ABSR INS-VIC INS-RAW INS-TST
processing			Textual description of the history of processings that lead to the current product and of all the relevant resources involved in the processing (facilities, software, applicable documents etc)		1	
	<b>name</b>	N.A.	Name of the Archiving process	string	0..1	Archiving of PDI Level-1A Datastrip Product
	<b>start</b>	General_Info->Archiving_Info ->ARCHIVING_TIME	Archiving start date (UTC)	xs:dateTime	0..1	
	facility		Description of Origin Centre		0..*	
	facility-> <b>name</b>	N.A.	Extended name of Origin Centre	string	1	
	facility-> <b>organization</b>	N.A.	Organization to which the Origin center belongs	string	0..1	
	facility-> <b>site</b>	General_Info->Archiving_Info ->ARCHIVING_CENTRE	The starting point of the circulation data	string enum	0..1	SGS_ MPS_ MTI_ EPA_ UPA_ CDAM MPC_



## Sentinel-2 Products Specification Document

REF : S2-PDGS-TAS-DI-PSD  
 ISSUE : 14.5  
 DATE : 14/03/2018  
 PAGE : 170 / 510

SAFE Manifest		From S2_PDI_Level-1A_Granule_Metadata.xsd	Description	Data Type	Occurrence	Allowed range of values
Metadata name	Name of tag or attribute (in bold)	Tag name				
	facility->country	N.A.	Country where Origin Centre is located	string	0..1	
	resource		Description of product being archived		0..*	
	resource->name	N.A.	Name of the product being archived	string	1	
	processing->resource->role	N.A.	Role of the resource	string	1	PDI Level-1A Granule Product
	resource-> processing		Description of the L0 to L1A Processing		0..*	
	resource-> processing->name	N.A.	Name of the L0 to L1A Processing	string	0..1	Processing of Level-0 Granule product
	resource-> processing->start	General_Info-> GRANULE_ID (substring <Creation Date> cf. section 3.5.6)	Processing start date (UTC)	xs:dateTime	0..1	
	resource-> processing->facility	N.A.	Description of Processing Centre		0..*	
	resource-> processing->facility->name	N.A.	Extended name of Origin Centre	string	1	
	resource-> processing->facility->organization	N.A.	Organization to which the Origin center belongs	string	0..1	
	resource-> processing->facility->site	General_Info-> GRANULE_ID (substring <Site Centre>)	Acronym of the Processing center	string enum	0..1	SGS_ MPS_ MTI_ EPA_ MPC_ UPA_





**Sentinel-2 Products  
Specification Document**

REF : S2-PDGS-TAS-DI-PSD  
 ISSUE : 14.5  
 DATE : 14/03/2018  
 PAGE : 171 / 510

SAFE Manifest		From S2_PDI_Level-1A_Granule_Metadata.xsd	Description	Data Type	Occurrence	Allowed range of values
Metadata name	Name of tag or attribute (in bold)	Tag name				
						XXXX EDRS zzzL (zzz = first three characters of the LGS location)
	resource-> processing-> facility-> <b>country</b>	N.A.	Country where Origin Centre is located	string	0..1	
	resource-> processing-> facility->software	N.A.	Description of software component used for Processing		0..*	
	resource-> processing-> facility->software-> <b>name</b>	N.A.	Name of the software component	string	1	
	resource-> processing-> facility->software-> <b>version</b>	N.A.	Version of the software component	string	0..1	
acquisitionPeriod					1	
	startTime	General_Info-> GRANULE_ID (substring <Sensing Time> cf. section 3.5.6)	Reference time of acquisition of the Granule (corresponding to sensing time of the first line of the PDI at Granule level, cf. section 3.5.6)	xs:dateTime	1	
measurementFrameSet					1	
	cloudVoteNotationSystem-> <b>floor</b>	N.A.	Minimum value of cloud coverage index (Fixed value = 0.0)	double	0..1	0.0
	cloudVoteNotationSystem-> <b>ceil</b>	N.A.	Maximum value of cloud coverage index (Fixed value = 100.0)	double	0..1	100.0





**Sentinel-2 Products  
Specification Document**

REF : S2-PDGS-TAS-DI-PSD  
ISSUE : 14.5  
DATE : 14/03/2018  
PAGE : 172 / 510

SAFE Manifest		From S2_PDI_Level-1A_Granule_Metadata.xsd	Description	Data Type	Occurrence	Allowed range of values
Metadata name	Name of tag or attribute (in bold)	Tag name				
	frame	N.A.	The "frame" concept is used in SAFE to convey the cloud coverage information by subdividing the region of interest of the data into "frames" according to a World Reference System. In the case of Sentinel-2 L1C Products, a similar concept can be used, by associating one single "frame" to the area covered by the granule (with respect to the reference band)		0..13	
	frame->number	N.A.	Number of the frame	integer	0..1	1
	frame-center	Geometric_Info->Granule_Position->Geometric_Header->GROUND_CENTER (only lat/lon coordinates, not height)	The Granule centre on ground	gml:PointType	0..1	
	frame->footPrint	Derived from Geometric_Info->Granule_Footprint	Granule footprint (namely imaged area corresponding to the Granule), corresponding to one detector and all bands	string(gml:linearRingType i.e. blank separated list of comma-separated lon/lat coordinates of footprint closed polygon with last vertex equal to first)	0..1	
	frame->Tile	N.A.			1	One Tile for the frame
	frame->Tile->row	N.A.	The column index of the Tile. This index is numbered starting from 1	integer	1	1 (since there is only one Tile)
	frame->Tile->column	N.A.	The row index of the Tile. This	integer	1	1 (since there is only



SAFE Manifest		From S2_PDI_Level-1A_Granule_Metadata.xsd	Description	Data Type	Occurrence	Allowed range of values
Metadata name	Name of tag or attribute (in bold)	Tag name				
			index is numbered starting from 1			one Tile)
	frame→Tile->cloudVote	Derived from Quality_Indicators_Info->Image_Content_QI->CLOUDY_PIXEL_PERCENTAGE	Numeric notation qualifying the cloud coverage of the Tile	double	0..1	0 to 100
metadataComponents		N.A	A reference to all Metadata files included in the product (e.g. the XML Metadata file, the XML Inventory Metadata file)		2..10	
metadataComponentSchemas		N.A	A reference to the Schemas used to validate the Metadata files included in the product (e.g. the XML Metadata file Schema)		0..2	

Table 43- Content of Metadata Section for PDI Level-1A Granule SAFE Manifest

### 3.8 Level-1A Datastrip PDI definition

Level-1A Datastrip PDI is defined as a tar file containing the following structure:

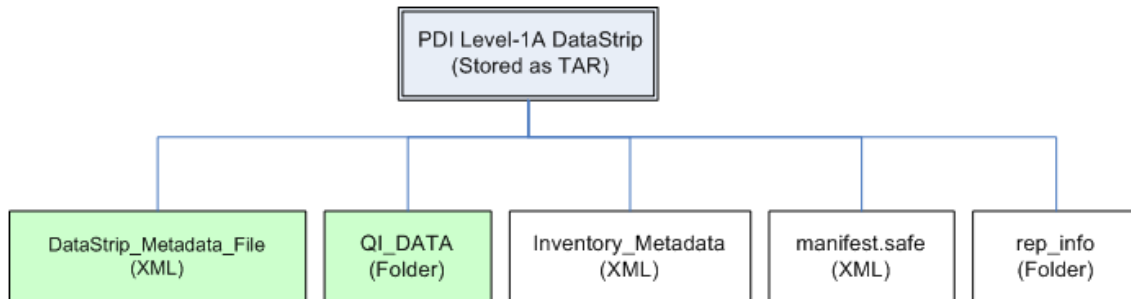

Figure 30: PDI Level-1A Datastrip Structure

The PDI Level-1A Datastrip consists of:

1. **Datastrip\_Metadata\_File**: XML metadata file containing the requested level of information and referring all the product elements composing the Datastrip,
2. **QI\_DATA**: folder containing XML reports about Quality control checks information,
3. **Inventory\_Metadata.xml**: file containing the metadata needed to inventory the PDI,
4. **manifest.safe**: XML SAFE Manifest file (mandatory, cf. section 3.5.4),
5. **rep\_info**: folder containing the available XSD schemas that validate the PDI components (recommended by [SAFE-SPEC], cf. section 3.5.4).

#### 3.8.1 PDI\_ID definition

Datastrip PDI\_ID (Datastrip ID) is defined in the section 3.5.2. The File\_Type is specified in the section 3.2, Table 5.

Level-1A Datastrip Template Name (Datastrip ID):

*S2A\_OPER\_MSI\_L1A\_DS\_SGS\_\_20141104T134012\_S20141106T134012\_N02.10.tar*

Note that the PDI\_ID.tar is the physical name of the Datastrip PDI after the tar compression.

### 3.8.2 Level-1A Datastrip Physical Format

The PDI ID defined above represents the “Datastrip directory” name. Inside the Datastrip directory, there are the Datastrip components as in the Figure 30.

Inside that directory, the naming convention used to identify each real files, follows the same convention used to define the Datastrip ID but without the Processing Baseline sub-string.

- **Datastrip\_Metadata\_File (XML file):**

Datastrip\_Metadata\_File template name:

*S2A\_OPER\_MTD\_L1A\_DS\_SGS\_\_20141104T134012\_S20141106T134012.xml*

The **schema, which regulates the metadata file**, is the one named *S2\_PDI\_Level-1A\_Datastrip\_Metadata.xsd* and included in the *S2-PDGS-TAS-DI-PSD-V14\_Schemas.zip* file annexed to the document.

- **QI\_DATA (folder):**

QI\_DATA folder contains XML reports *OLQC\_Report.xml* generated by On-Line Quality Control processor, including Quality Control Checks results. The *OLQC\_Report.xsd* schema and the reports naming convention are in the Annex C of the document.

File Template Name:

*S2A\_OPER\_MSI\_L1A\_DS\_SGS\_\_20141104T134012\_S20141106T134012\_GEOMETRIC\_QUALITY\_report.xml*

- **Inventory\_Metadata (XML file):**







XML Inventory metadata file with fixed name *Inventory\_Metadata.xml*

- **rep\_info (folder):**

Folder containing the following XSD schemas:

1. *S2\_PDI\_Level-1A\_Datastrip\_Metadata.xsd*
2. *Inventory\_Metadata.xsd*
3. *OLQC\_Report.xsd*

Level-1A Datastrip Physical Format template:

Level-1A Datastrip PDI ID: <i>S2A_OPER_MSI_L1A_DS_SGS__20141104T134012_S20141106T134012_N02.10</i>	
	<i>Inventory_Metadata.xml</i>
	<i>S2A_OPER_MTD_L1A_DS_SGS__20141104T134012_S20141106T134012.xml</i>
	<i>manifest.safe</i>
	QI_DATA
	<i>S2A_OPER_MSI_L1A_DS_SGS__20141104T134012_S20141106T134012_GEOMETRIC_QUALITY_report.xml</i>
	rep_info



*S2\_PDI\_Level-1A\_Datastrip\_Metadata.xsd*  
*Inventory\_Metadata.xsd*  
*OLQC\_Report.xsd*

Figure 31: PDI Level-1A Datastrip Physical Format



### 3.8.3 Level-1A Datastrip PDI Structure

The *S2\_PDI\_Level-1A\_Datastrip\_Structure.xsd* schema annexed to the document and shown in the following diagram, represents the organization of a Level-1A Datastrip PDI on. This schema is provided for information only as it is actually not expected to be used for the validation of a XML file. The diagram reflects exactly the Figure 30.

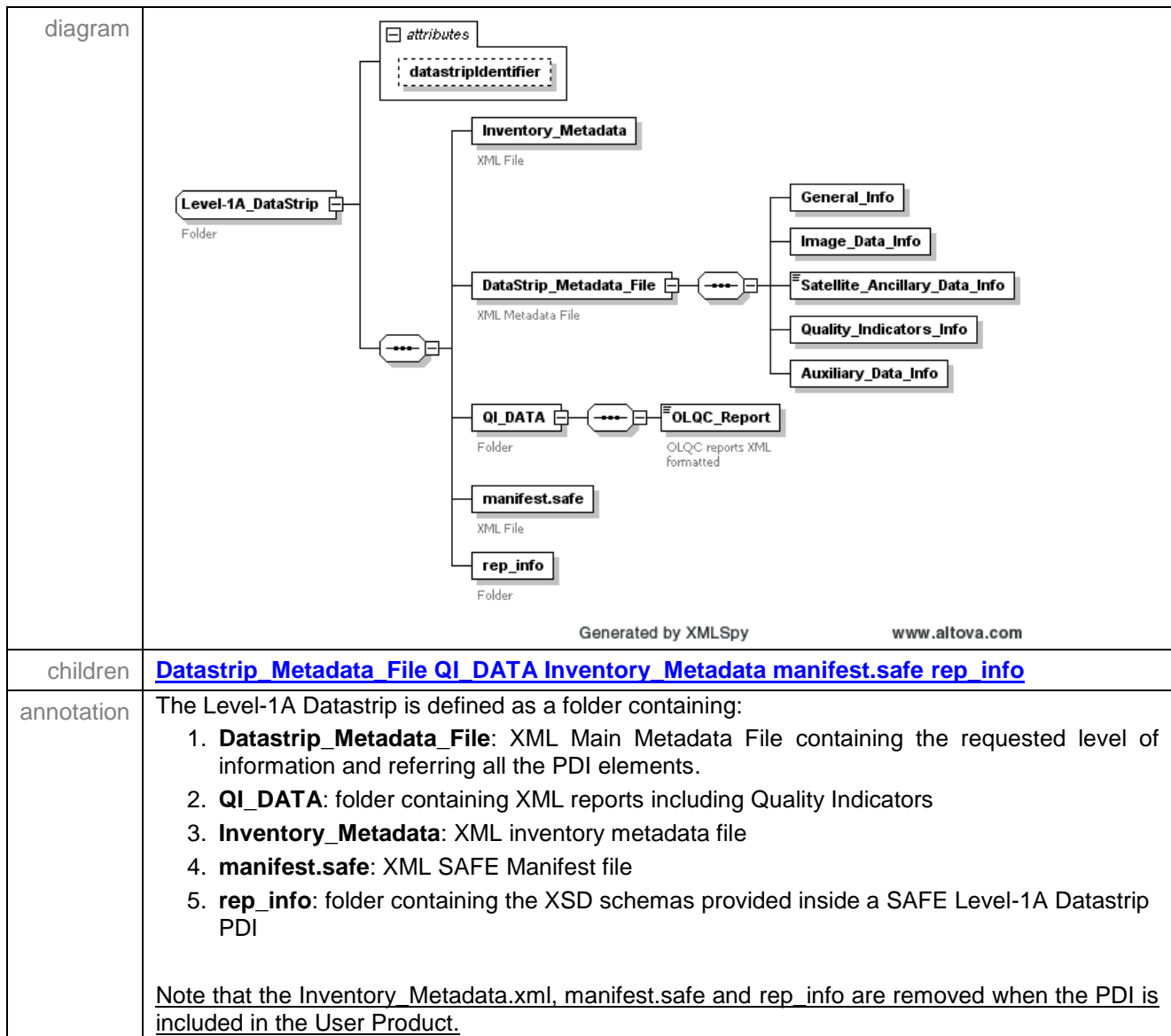

#### 3.8.3.1 Datastrip\_Metadata\_File Schema

Level-1A Datastrip\_Metadata\_File is the main XML metadata file provided inside each Level-1A Datastrip. The schema used to validate it is *S2\_PDI\_Level-1A\_Datastrip\_Metadata.xsd* annexed to

this document. A detailed description of the schema is given here but for specific details regarding each metadata (e.g. type, default value, fixed value, enumerations, occurrences, etc...) refers to the XSD file.

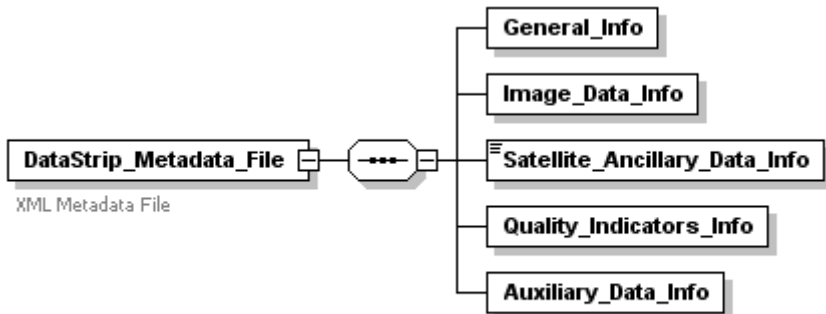
diagram	 <p align="center">Generated by XMLSpy <span style="float:right">www.altova.com</span></p>
children	<a href="#">Datastrip_Metadata_File QI DATA Inventory_Metadata_manifest.safe rep_info</a>
annotation	<p>The structure of the Datastrip_Matadata_File is common to all processing level (cfr. § 3.5.1) The Datastrip_Metadata_File is an XML file containing all the metadata describing the whole product data item.</p> <ol style="list-style-type: none"> <li>1. <b>General_Info</b>: This group of metadata provide general information characterizing the source Datastrip acquisition.</li> <li>2. <b>Image_Data_Info</b>: Image data information from MSI telemetry.</li> <li>3. <b>Satellite_Ancillary_Data_Info</b>: Ancillary data information from Satellite Ancillary Telemetry.</li> <li>4. <b>Quality_Indicators_Info</b>: Results of all quality checks performed at Datastrip level.</li> <li>5. <b>Auxiliary_Data_Info</b>: Auxiliary data information.</li> </ol>

The following tables and figures give a complete overview of the Level-1A Datastrip\_Metadata\_File schema according the description provided in the section 3.5.1.

The General\_Info provided through the Level-1A DataSrip\_Metadata\_File are the same described in the Figure 20 and Table 34.

General Info:

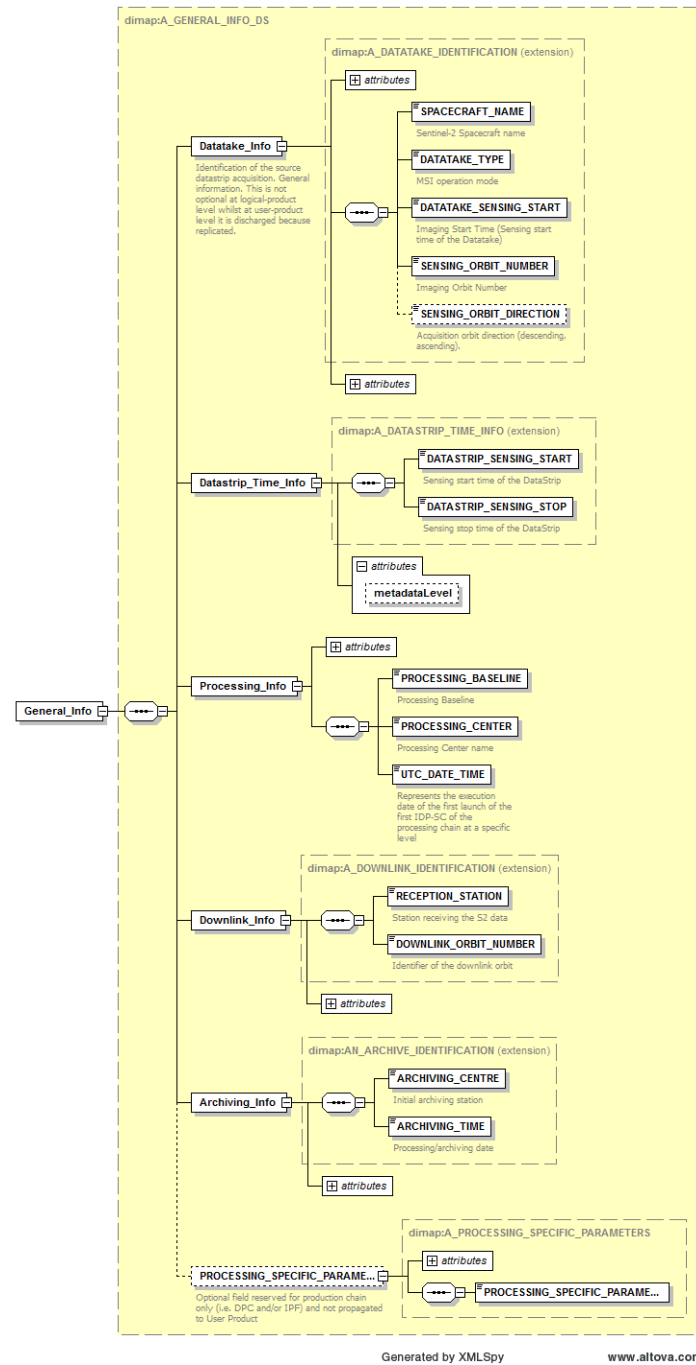

Figure 32: Level-1A Datastrip - General\_Info Diagram



## Sentinel-2 Products Specification Document

REF : S2-PDGS-TAS-DI-PSD  
ISSUE : 14.5  
DATE : 14/03/2018  
PAGE : 180 / 510

General_Info/Datatake_Info		
Field Name	Description	Metatada Level
SPACECRAFT_NAME	Sentinel-2 Spacecraft name: Sentinel-2A, Sentinel-2B	Brief
DATATAKE_TYPE	MSI operation mode	Brief
DATATAKE_SENSING_START	Imaging Start Time (Sensing start time of the Datatake)	Brief
SENSING_ORBIT_NUMBER	Imaging Orbit Number	Brief
SENSING_ORBIT_DIRECTION	Imaging Orbit Direction (Default = Ascending)	Brief
General_Info/Datastrip_Time_Info		
Field Name	Description	Metatada Level
DATASTRIP_SENSING_START	Sensing start time of the Datastrip	Brief
DATASTRIP_SENSING_STOP	Sensing stop time of the Datastrip	Brief
General_Info/Processing_Info		
Field Name	Description	Metatada Level
PROCESSING_BASELINE	The processing baseline refers to the configuration baseline used at the time of the generation in term of processor software version and major GIPP version (cf. section 2.9).  Note: all the PDIs of a Datatake are always processed with the same processing baseline even if acquiered in different stations	Brief
UTC_DATA_TIME	This data time represents the execution date of the first run of the first IDP-SC of the processing chain at a specific level	Expertise
PROCESSING_CENTER	Production centre: <ul style="list-style-type: none"><li>• SGS_</li><li>• MPS_</li><li>• MTI_</li><li>• EPA_</li><li>• MPC_</li><li>• UPA_</li><li>• XXXX</li></ul>	Expertise



	<ul style="list-style-type: none"> <li>• EDRS</li> <li>• zzzL (zzz = first three characters of the LGS location)</li> </ul>	
<b>General_Info/Downlink_Info</b>		
<b>Field Name</b>	<b>Description</b>	<b>Metatada Level</b>
RECEPTION_STATION	Reception stations: <ul style="list-style-type: none"> <li>• SGS_</li> <li>• MPS_</li> <li>• MTI_</li> </ul>	Standard
DOWNLINK_ORBIT_NUMBER	Identifier of the downlink orbit	Standard
<b>General_Info/Archiving_Info</b>		
<b>Field Name</b>	<b>Description</b>	
ARCHIVING_CENTRE	The allowed values are: <ul style="list-style-type: none"> <li>• SGS_</li> <li>• MPS_</li> <li>• MTI_</li> <li>• EPA_</li> <li>• UPA_</li> <li>• CDAM</li> <li>• MPC_</li> </ul>	Expertise
ARCHIVING_TIME	Processing/archiving date (UTC data time)	Expertise
Processing_Specific_Parameters/ PROCESSING_SPECIFIC_PARAMETERS	Optional field reserved for production chain only (NOT propagated to User Product)	Expertise

Table 44: Level-1A Datastrip - General\_Info Description

Image Data Info:

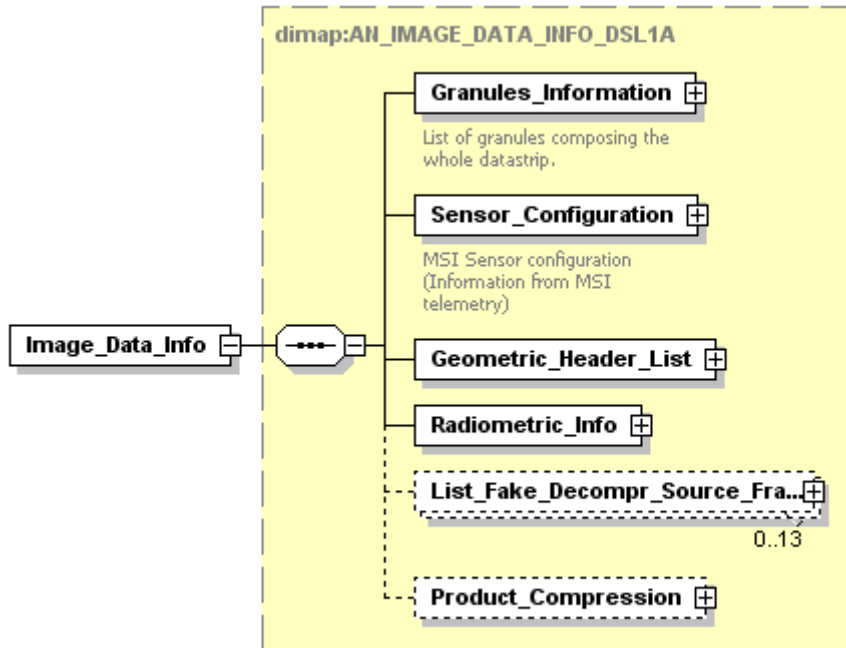

Generated by XMLSpy

[www.altova.com](http://www.altova.com)

Figure 33 : Level-1A Datastrip – Image\_Data\_Info Diagram



**Sentinel-2 Products  
Specification Document**

REF : S2-PDGS-TAS-DI-PSD  
ISSUE : 14.5  
DATE : 14/03/2018  
PAGE : 183 / 510

Image_Data_Info/Granules_Information		
Field Name	Description	Metatada Level
Detector_List/Detector/Granule_List/Granule/POSITION	This branch of the schema provides information regarding all Granules, for each detector, composing the whole Datastrip. Each Granule composing the Datastrip is univocally identified trough a unique Granule identifier (PDI_ID at granul level). For each Granule the Position of the Granule is provided. This position is identified through the position of the scenes first lines in the Datastrip and is expressed as number of 10m resolution images lines.	Standard
Image_Data_Info/Sensor_Configuration (inherited from Level-0 metadata)		
Field Name	Description	Metatada Level
Acquisition_Configuration/COMPRESS_MODE	Flag to indicate if compress mode is by passed	Expertise
Acquisition_Configuration/EQUALIZATION_MODE	Flag to indicate if equalization is active	Expertise
Acquisition_Configuration/NUC_TABLE_ID	In-flight Non Uniform Correction table ID defined by 10 bits. This ID is uniform for all transmitted bands. It identifies the correction coefficients table used in-flight	Expertise
Acquisition_Configuration/Active_Detectors_List	On board active Detectors (in case of compression by-passed)	Expertise
Acquisition_Configuration/TDI_Configuration_List	On board TDI configuration, for B3, B4, B11 and B12 only.	Standard
Acquisition_Configuration/Spectral_Band_Info/PHYSICAL_GAIN	Physical Gain for each band	Standard
Acquisition_Configuration/Spectral_Band_Info/COMPRESSION_RATE	On-board compression rates for each band	Expertise
Acquisition_Configuration/Spectral_Band_Info/INTEGRATION_TIME	On-board integration time for each band	Expertise
Source_Packet_Description	Source packet information for each band	Standard
Time_Stamp/LINE_PERIOD	Line period for the acquisition of line of 10 m full-resolution image data	Standard
Time_Stamp/Band_Time_Stamp/Detector	Datation model for each couple band, detector.	Standard





**Sentinel-2 Products  
Specification Document**

REF : S2-PDGS-TAS-DI-PSD  
 ISSUE : 14.5  
 DATE : 14/03/2018  
 PAGE : 184 / 510

Time_Stamp/GPS_SYNC	Flag (Boolean) to indicate if MSI is synchronize with GPS time	Standard
Time_Stamp/THEORETICAL_LINE_PERIOD	Theoretical line period for the acquisition of line of 10 m full-resolution image data	Standard
Time_Stamp/Quality_Indicators	Optional. Created when datation models are estimated through linear regression.	Standard
<b>Image_Data_Info/Geometric_Header_List(inherited from Level-0 metadata)</b>		
<b>Field Name</b>	<b>Description</b>	<b>Metatada Level</b>
Geometric_Header_List	Geometric information.  For all details see Table 35, section "Image_Data_Info/Geometric_Header_List"	Standard Expertise
<b>Image_Data_Info/Radiometric_Info</b>		
<b>Field Name</b>	<b>Description</b>	<b>Metatada Level</b>
SWIR_REARRANGEMENT_PROC	SWIR pixels re-arrangement (only for level 1A production but SWIR rearrangement information shall be preserved in L1B and L1C): A 'true' value indicates that data extraction and SWIR pixels re-arrangement have been processed.	Standard
DEFECTIVE_PIXELS_PROC	Defective pixels processing. A 'true' value indicates that defective pixels have been detected and processed, a 'detection' value indicates that defective pixels have been only detected (only for level 1A production), a 'false' value indicates that defective pixels have been neither detected nor processed.	Standard
PIXELS_NO_DATA_PROC	Management of NO_DATA pixels. A 'true' value indicates that NO_DATA pixels have been detected and processed, a 'detection' value indicates that NO_DATA pixels have been only detected (only for level 1A production), a 'false' value indicates that NO_DATA pixels have been neither detected nor processed.	Standard
SATURATED_PIXELS_PROC	Management of saturated pixels. A 'true' value	Standard







**Sentinel-2 Products  
Specification Document**

REF : S2-PDGS-TAS-DI-PSD  
ISSUE : 14.5  
DATE : 14/03/2018  
PAGE : 185 / 510

	indicates that saturated pixels has been processed.	
Spectral_Information_List/Spectral_Information/RESOLUTION	(OPTIONAL branch)  Spectral filter information provided by the GIPP ABSOLUTE_CALIBRATION  Spatial resolution	Standard
Spectral_Information_List/Spectral_Information/Wavelength/MIN	Minimum wavelength	Standard
Spectral_Information_List/Spectral_Information/Wavelength/MAX	Maximum wavelength	Standard
Spectral_Information_List/Spectral_Information/Wavelength/CENTRAL	Central wavelength	Standard
Spectral_Information_List/Spectral_Information/Spectral_Response/STEP	Step of spectral response	Standard
Spectral_Information_List/Spectral_Information/Spectral_Response/VALUES	List of measures	Standard
Image_Display_Order/RED_CHANNEL	Relation between product image channels and on board spectral bands (Band index).	Brief
Image_Display_Order/GREEN_CHANNEL	Relation between product image channels and on board spectral bands (Band index).	Brief
Image_Display_Order/BLUE_CHANNEL	Relation between product image channels and on board spectral bands (Band index).	Brief
<b>Image_Data_Info/List_Fake-Decompr_Source_Frames</b>		
<b>Field Name</b>	<b>Description</b>	<b>Metatada Level</b>
List_Fake-Decompr_Source_Frames	List of the decompressed sources frames  This field will be better specify as soon as the MRCPBG CFI documentation is available.	Standard
<b>Image_Data_Info/Product_Compression (OPTIONAL BRANCH)</b>		
<b>Field Name</b>	<b>Description</b>	<b>Metatada Level</b>
COMPRESSION	Product Compression.  The compression may be: - None. - LOSSLESS: Lossless compression, use reversible JPEG2000 compression. - LOSSY: Lossy compression, use	Standard





**Sentinel-2 Products  
Specification Document**

REF : S2-PDGS-TAS-DI-PSD  
ISSUE : 14.5  
DATE : 14/03/2018  
PAGE : 186 / 510

	compression that ensures that JPEG2000 compression has a negligible effect on image quality.	
--	--	--

Table 45: Level-1A Datastrip – Image\_Data\_Info Description



Satellite Ancillary Data Info:

Satellite\_Ancillary\_Data\_Info are the same provided for a L0 Datastrip (cfr. Figure 22 and Table 36).

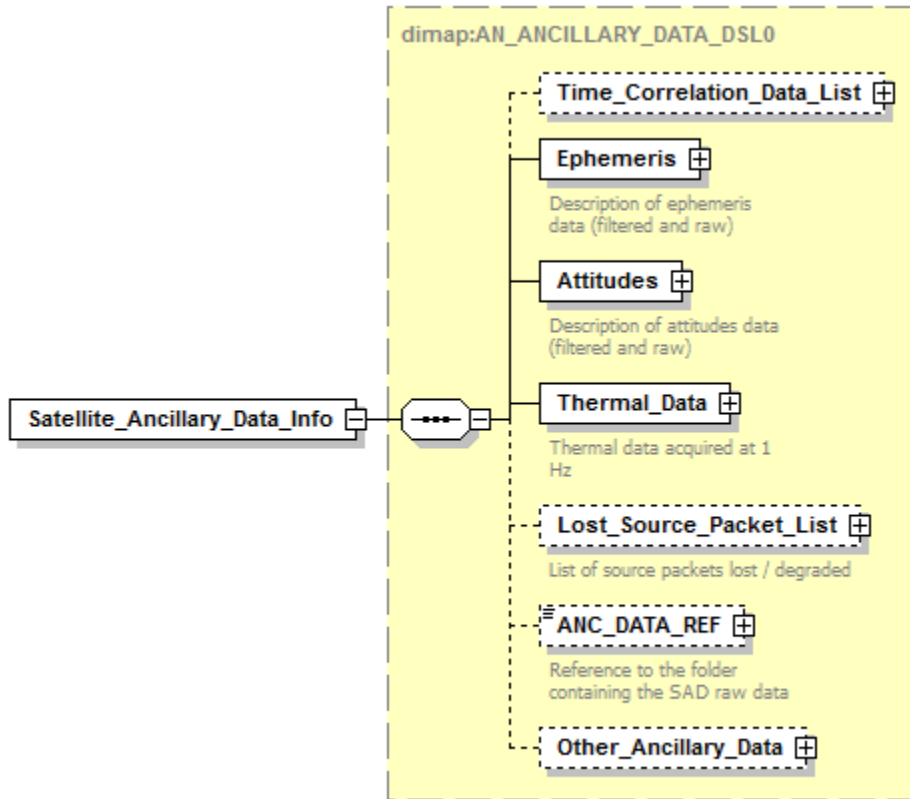

Generated by XMLSpy

www.altova.com

Figure 34: Level-1A Datastrip – Satellite\_Ancillary\_Data\_Info Diagram

Satellite_Ancillary_Data_Info		
Field Name	Description	Metatada Level
Satellite_Ancillary_Data_Info	Inherited from Level-0 (cf. Table 36)	§ Table 36

Table 46: Level-1A Datastrip – Satellite\_Ancillary\_Data\_Info Description

Quality Indicators Info:

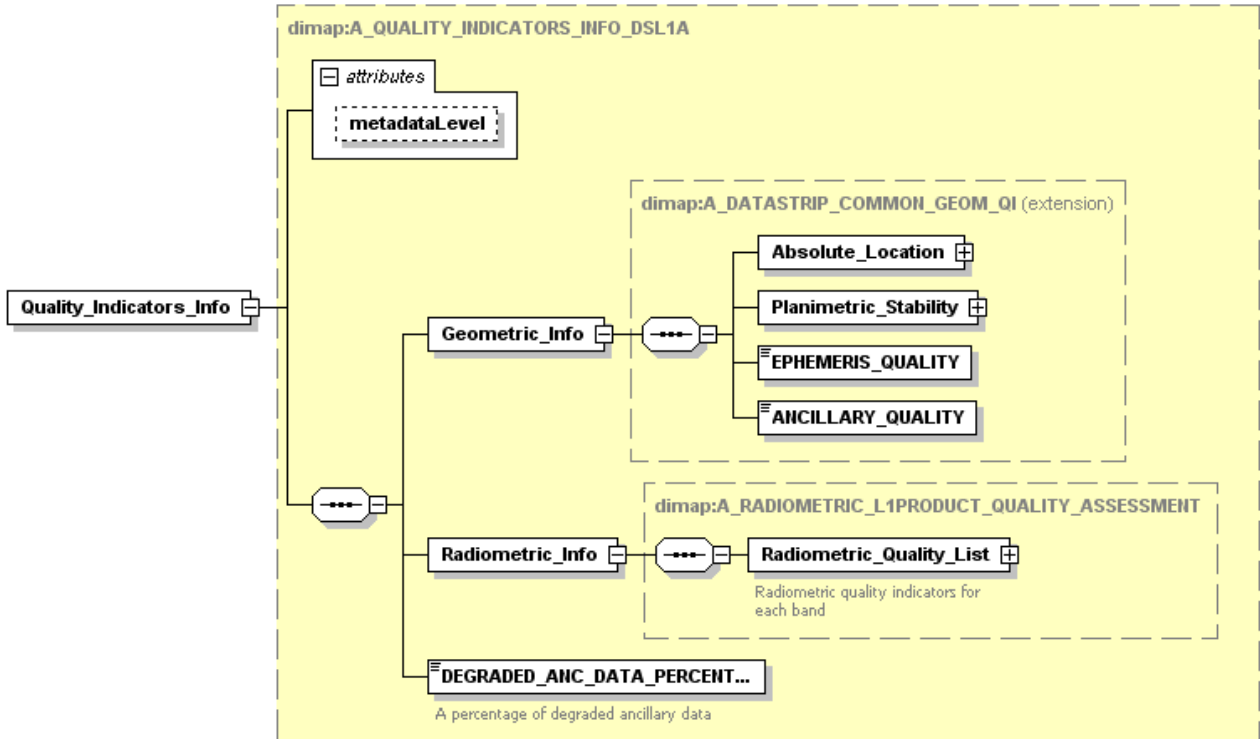

Generated by XMLSpy

www.altova.com

Figure 35 : Level-1A Datastrip – Quality\_Indicators\_Info Diagram



**Sentinel-2 Products  
Specification Document**

REF : S2-PDGS-TAS-DI-PSD  
 ISSUE : 14.5  
 DATE : 14/03/2018  
 PAGE : 189 / 510

Quality_Indicators_Info/Geometric_Info		
Field Name	Description	Metatada Level
Absolute_Location	An absolute location performance for the Datastrip is given from a GIPP table, depending on the health status of the GPS and AOCS sensors (gyros and startrackers) provided in the Satellite Ancillary Data.	Brief
Planimetric_Stability	Planimetric stability assessment: A planimetric stability performance for the Datastrip is given from a GIPP table, depending on the health status of the GPS and AOCS sensors (gyros and startrackers) provided in the Satellite Ancillary Data	Brief
EPHEMERIS_QUALITY	Ephemeris data quality retrieved from GPS Dilution of precision (DOP) information	Brief
ANCILLARY_QUALITY	Ancillary data quality retrieved from GPS Dilution of precision (DOP) information.	Brief
Quality_Indicators_Info/Radiometric_Info		
Field Name	Description	Metatada Level
Noise_Model	Alpha and Beta parameters providing the instrument noise as a function of the radiometric count X for Level-1B : Noise= square root(Alpha_X + Beta_X* X)	Brief
ABSOLUTE_CALIBRATION_ACCURACY	Absolute calibration accuracy provided	Brief





**Sentinel-2 Products  
Specification Document**

REF : S2-PDGS-TAS-DI-PSD  
ISSUE : 14.5  
DATE : 14/03/2018  
PAGE : 190 / 510

	as a percentage of accuracy	
CROSS_BAND_CALIBRATION_ACCURACY	Cross-band calibration accuracy provided as a percentage of accuracy	Brief
MULTI_TEMPORAL_CALIBRATION_ACCURACY	Multi-temporal calibration accuracy provided as a percentage of accuracy	Brief
DEGRADED_ANC_DATA_PERCENTAGE	Percentage of degraded ancillary data	Brief

Table 47: Level-1A Datastrip - Quality\_Indicators\_Info Description



Auxiliary Data Info:

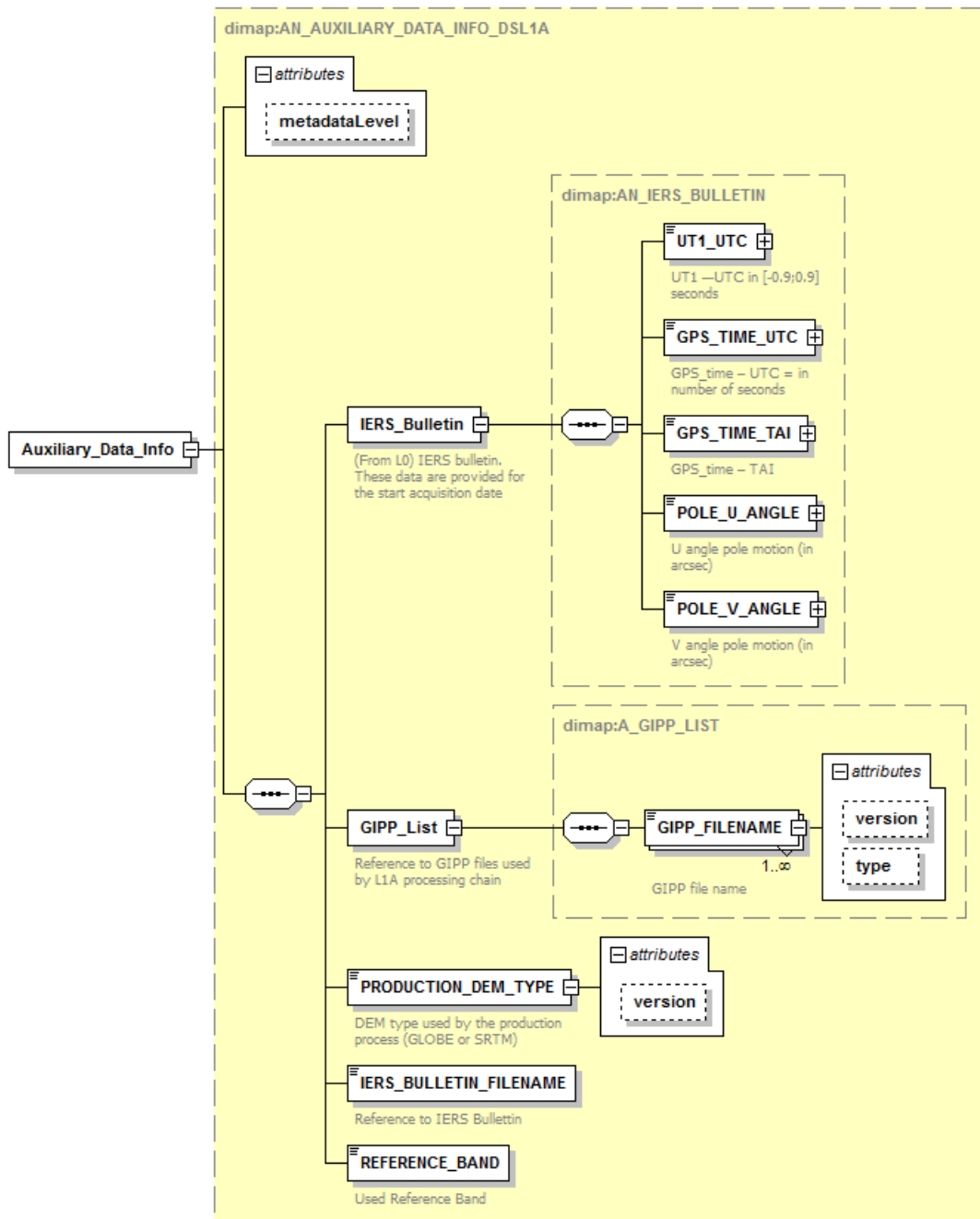

Generated by XMLSpy

www.altova.com

Figure 36 : Level-1A Datastrip – Auxiliary\_Data\_Info Diagram



**Sentinel-2 Products  
Specification Document**

REF : S2-PDGS-TAS-DI-PSD  
 ISSUE : 14.5  
 DATE : 14/03/2018  
 PAGE : 192 / 510

Auxiliary_Data_Info/IERS_Bulletin (aux info from Level-0)		
Field Name	Description	Metatada Level
UT1.UTC	UT1 --UTC in [-0.9;0.9] seconds	Standard
GPS_TIME.UTC	GPS_time – UTC = in number of seconds	Standard
GPS_TIME.TAI	GPS_time – TAI	Standard
POLE_U.ANGLE	U angle pole motion (in arcsec)	Standard
POLE_V.ANGLE	V angle pole motion (in arcsec)	Standard
Auxiliary_Data_Info (aux data used by the processing)		
Field Name	Description	Metatada Level
GIPP_Filename	Reference to the GIPP files used by the L1A processing.	Standard
PRODUCTION_DEM_TYPE	DEM type used by the production process (GLOBE or SRTM for example)	Standard
IERS_BULLETIN_FILENAME	Filename of the used IERS Bulletin	Standard
Auxiliary_Data_Info (others aux info)		
Field Name	Description	Metatada Level
REFERENCE_BAND	Used reference band for datation	Standard

Table 48: Level-1A Datasrip – Auxiliary\_Data\_Info Description



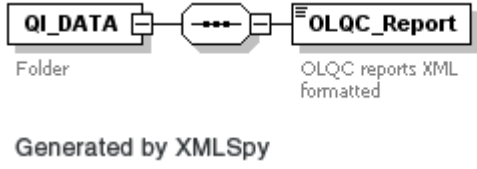

### 3.8.3.2 QI\_DATA

diagram	
children	<a href="#">OLQC_Report</a>
annotation	QI_DATA folder contains XML reports generated by On-Line Quality Control processor, including Quality Control Checks results. The Annex C contains the description of OLQC reports.

### 3.8.4 SAFE Manifest synoptic table

This chapter provides a detailed description of the content of the SAFE Manifest for the Level-1A Datastrip PDI level.

The SAFE Manifest file is compliant to the SAFE specification (cf. [SAFE-SPEC]) and is composed (cf. section 3.4.4) by three main sections (Metadata, Information Package Map and Data Objects).

Part of the information contained in the Metadata section is extracted from the XML metadata file and is therefore duplicated in the SAFE Manifest and in the XML metadata file.

With reference to the three mentioned sections the chapter provides, as a guideline to the generation process of the SAFE Manifest file, the following elements:

- Table 31 describing the content and structure of the Information Package Map section; same consideration apply as in section 3.5.9;
- for the Metadata Section, a table that lists the fields (tags) composing the section, providing, for each field:
  - the field name in the SAFE Manifest file (column “SAFE Manifest”, divided into column “Metadata name”, containing the name of the Metadata section of the manifest to which the field belongs, and “Name of tag or attribute” containing the actual tag name or attribute name (for sake of clarity, attributes are written in bold characters))
  - the name of the corresponding tag (if available, else N.A.) of the XML Metadata File and of its XSD Schema (column “From S2\_PDI\_Level-1A\_Datastrip\_Metadata.xsd”);
  - a brief textual description of the field;
  - the data type of the field (e.g. string, string enum, integer, double, xs:dateTime etc.);
  - the occurrence of the field (min/man occurrence e.g. 0..1); a minimum occurrence of 1 means that the field is mandatory;
  - the allowed range of values of the field.

In particular, the satellite ancillary data files (e.g. the SAD Raw Data file) and the auxiliary data files used for Level-1A processing (e.g. GIPP files, DEM, IERS Bulletin), are external to the product and are referenced in the Metadata of Manifest file Section (as “resources” in the “processing” section).

- Table 33 describing the content and structure of the Data Objects section; consider that this section contains a reference to each file (Data files and Metadata files) composing the Level-1A PDI (with the exception of the Manifest file itself); this includes:
  - the XML Metadata file;
  - the XML Inventory\_Metadata file;
  - a set of Quality Indicator Data Files, including a OLQC Report file (XML format) and five Preliminary Quick Look files (in JPEG2000 format).

An example of Manifest file for the Level-1A Datastrip PDI containing realistic, though indicative values, is provided as annexed zip file to this document (S2-PDGS-TAS-DI-PSD-

V14\_SAFE.zip); the Manifest is provided as an example, but its compliancy to the SAFE specification has been verified by validating the Manifest file against the SAFE XSD schema.

SAFE Manifest		From <i>S2_PDI_Level-0_Datastrip_Metadata.xsd</i>	Description	Data Type	Occurrence	Allowed range of values
Metadata name	Name of tag or attribute (in bold)	Tag name				
platform						
	nssdcIdentifier	N.A.	Unique identifier of the platform, defined by the World Data center for Satellite Information (WDC-SI)		1	WDC is discontinued; this tag is set to a default value 0000-0000
	familyName	General_Info->Datatake_Info->SPACECRAFT_NAME	The mission name of the platform	string enum	0..1	Sentinel
	number	General_Info->Datatake_Info->SPACECRAFT_NAME	Sequence identifier of the platform among the mission	string enum	0..1	2A, 2B, 2C
	instrument->familyName	N.A.	The instrument name used for acquiring the product data	string enum	0..1	Multi-Spectral Instrument
	instrument-> <b>abbreviation</b>	N.A.	Abbreviation of the instrument name	string enum	0..1	MSI
	instrument->mode	N.A.	The mode of the instrument	string enum	0..1	Nominal_Observation Dark_Signal_Calibration Extended_Observation Absolute_Radiometry_Calibration Vicarious_Calibration Raw_Measurement Test_Mode
	Instrument->mode-> <b>identifier</b>	General_Info->Datatake_Info->DATATAKE_TYPE	The identifier of the instrument mode	string enum	1	INS-NOBS INS-EOBS INS-DASC INS-ABSR INS-VIC INS-RAW

SAFE Manifest		From <i>S2_PDI_Level-0_Datastrip_Metadata.xsd</i>	Description	Data Type	Occurrence	Allowed range of values
Metadata name	Name of tag or attribute (in bold)	Tag name				
						INS-TST
processing			Textual description of the history of processings that lead to the current product and of all the relevant resources involved in the processing (facilities, software, applicable documents etc)		1	
	<b>name</b>	N.A.	Name of the Archiving process	string	0..1	Archiving of PDI Level-1A Granule Product
	<b>start</b>	General_Info->Archiving_Info->ARCHIVING_TIME	Archiving start date (UTC)	xs:dateTime	0..1	
	facility		Description of Origin Centre		0..*	
	facility-> <b>name</b>	N.A.	Extended name of Origin Centre	string	1	
	facility-> <b>organization</b>	N.A.	Organization to which the Origin center belongs	string	0..1	
	facility-> <b>site</b>	General_Info->Archiving_Info ->ARCHIVING_CENTRE	The starting point of the circulation data	string enum	0..1	SGS_ MPS_ MTI_ EPA_ UPA_ CDAM MPC_
	facility-> <b>country</b>	N.A.	Country where Origin Centre is located	string	0..1	



**Sentinel-2 Products  
Specification Document**

REF : S2-PDGS-TAS-DI-PSD  
ISSUE : 14.5  
DATE : 14/03/2018  
PAGE : 198 / 510

SAFE Manifest		From <i>S2_PDI_Level-0_Datastrip_Metadata.xsd</i>	Description	Data Type	Occurrence	Allowed range of values
Metadata name	Name of tag or attribute (in bold)	Tag name				
	resource		Description of product being archived		0..*	
	resource-> <b>name</b>	N.A.	Name of the product being archived	string	1	
	resource-> <b>role</b>	N.A.	Role of the resource	string	1	PDI Level-1A Granule Product
	resource-> processing		Description of the L0 to L1A Processing		0..*	
	resource-> processing-> <b>name</b>		Name of the L0 to L1A Processing	string	0..1	Processing of Level-0 Datastrip product
	resource-> processing-> <b>start</b>	General_Info->Processing_Info->UTC_DATE_TIME	Processing start date (UTC)	xs:dateTime	0..1	
	resource-> processing-> facility	N.A.	Description of Processing Centre		0..*	
	resource-> processing-> facility-> <b>name</b>	N.A.	Extended name of Origin Centre	string	1	
	resource-> processing-> facility-> <b>organization</b>	N.A.	Organization to which the Origin center belongs	string	0..1	
	resource-> processing-> facility-> <b>site</b>	General_Info->Processing_Info->PROCESSING_CENTER	Acronym of the Processing center	string enum	0..1	SGS_ MPS_ MTI_ EPA_ MPC_ UPA_ XXXX EDRS zzzL (zzz = first three characters of the LGS location)



SAFE Manifest		From <i>S2_PDI_Level-0_Datastrip_Metadata.xsd</i>	Description	Data Type	Occurrence	Allowed range of values
Metadata name	Name of tag or attribute (in bold)	Tag name				
	resource-> processing-> facility-> <b>country</b>	N.A.	Country where Origin Centre is located	string	0..1	
	resource-> processing-> facility->software		Description of software component used for Processing		0..*	
	resource-> processing-> facility->resource		List of auxiliary data files used by the processors to support radiometric and geometric correction (GIPP, DEM, GRI, IERS Bulletin etc. and of SAD Raw Data file containing the satellite ancillary telemetry; these files are not provided with the product.		0..*	
	resource-> processing-> facility->resource-> <b>name</b>	Satellite_Ancillary_Data_Info->ANC_DATA_REF (reference to the folder containing the SAD Raw Data files) Auxiliary_Data_Info->IERS_Bulletin Auxiliary_Data_Info->GIPP_List->GIPP_FILENAME	Absolute path name of the auxiliary or ancillary file/folder	string	1	
	resource-> processing-> facility->resource-> <b>role</b>	N.A.	Role of the resource	string	1	Auxiliary data, Ancillary data
acquisitionPeriod					1	
	acquisitionPeriod ->startTime	Datastrip->L1A_Datastrip_PDI_ID (substring <Sensing Time>, cf. section 3.5.6)	Reference time of acquisition of the Granule (corresponding	xs:dateTime	1	



**Sentinel-2 Products  
Specification Document**

REF : S2-PDGS-TAS-DI-PSD  
ISSUE : 14.5  
DATE : 14/03/2018  
PAGE : 200 / 510

SAFE Manifest		From S2_PDI_Level-0_Datastrip_Metadata.xsd	Description	Data Type	Occurrence	Allowed range of values
Metadata name	Name of tag or attribute (in bold)	Tag name				
			to sensing time of the first line of the PDI at Datastrip level, cf. section 3.5.6)			
measurementOrbitReference						
	orbitNumber	General_Info->Datatake_Info->DatatakeIdentifier (substring <AbsoluteOrbitNumber>)	Absolute orbit number		0..1	> 0
	orbitNumber->type	N.A.	Absolute orbit number type (possible values "start" or "stop"). Set to "start" since the absolute orbit number refers to the first line of the Datastrip		0..1	start
	orbitNumber->groundTrackDirection	General_Info->Datatake_Info->SENSING_ORBIT_DIRECTION	Direction of the ground track of the Sentinel-2 platform at the time corresponding to orbitNumber->type (start or stop)		0..1	ascending, descending
	relativeOrbitNumber	General_Info->Datatake_Info->SENSING_ORBIT_NUMBER	Relative orbit number (within the cycle)		0..1	1 to 143
	relativeOrbitNumber->type	N.A.	Relative orbit number type (possible values "start" or "stop"). Set to "start" since the absolute orbit number refers to the first line of the		0..1	start





SAFE Manifest		From <i>S2_PDI_Level-0_Datastrip_Metadata.xsd</i>	Description	Data Type	Occurrence	Allowed range of values
Metadata name	Name of tag or attribute (in bold)	Tag name				
			Datastrip			
metadataComponents		N.A	A reference to all Metadata files included in the product (e.g. the XML Metadata file, the XML Inventory Metadata file)		2..4	
metadataComponentSchemas		N.A	A reference to the Schemas used to validate the Metadata files included in the product (e.g. the XML Metadata file Schema)		0..2	

Table 49 - Content of Metadata Section for PDI Level-1A Datastrip SAFE Manifest

### 3.9 Level-1B Granule PDI definition

Level-1B Granule PDI level is defined as a **tar** file with the following structure:

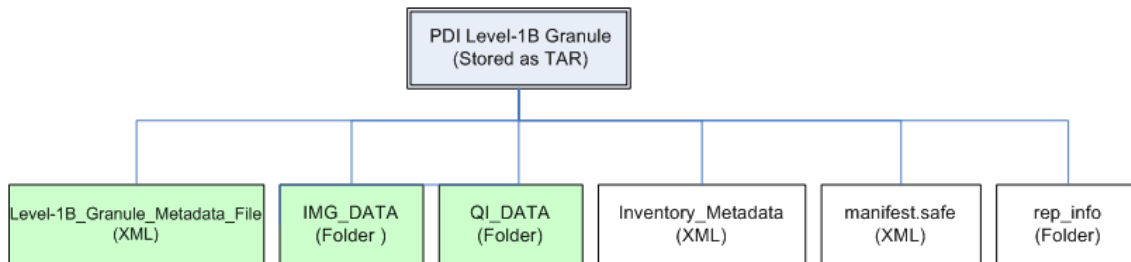

Figure 37: PDI Level-1B Granule Structure

The PDI Level-1B Granule consists of:

1. **Level-1B\_Granule\_Metadata\_File**: XML metadata file containing the requested level of information and referring all the product elements composing the Granule,
2. **IMG\_DATA**: folder containing the mission data corresponding to one on-board scene for one detector and all spectral bands,
3. **QI\_DATA**: folder containing XML reports including Quality control checks and Quality Mask files;
4. **Inventory\_Metadata.xml**: file containing the metadata needed to inventory the PDI;
5. **manifest.safe**: XML SAFE Manifest file (mandatory, cf. section 3.9.4);
6. **rep\_info**: folder containing the available XSD schema that validate the PDI components (recommended by [SAFE-SPEC], cf. section 3.4.4).

#### 3.9.1 PDI\_ID definition

The PDI\_ID (Granule ID) used to identify a Level-1B Granule PDI, follows the description provided in the section 3.4.2. File\_Type is defined in the section 3.2, Table 5.

Level-1B Granule Template Name (Granule ID):

*S2A\_OPER\_MSI\_L1B\_GR\_MTI\_\_20141104T134012\_S20141104T134012\_D11\_N05.22.tar*

Note that the PDI\_ID.tar is the physical name of the Granule PDI after the tar compression.

### 3.9.2 Level-1B Granule Physical Format

The PDI ID defined above represents the “Granule directory” name. Inside the Granule directory, there are the Granule components as in the Figure 37:

Inside that directory, the naming convention used to identify each real files, follows the same convention used to define the Granule ID except for the Processing Baseline sub-string.

- **Level-1B\_Granule\_Metadata\_File (XML file):**

Granule Metadata File Template name

*S2A\_OPER\_MTD\_L1B\_GR\_MTI\_20141104T134012\_S20141104T134012\_D11.xml*

The XSD schema, which regulates the metadata file, is the *S2\_PDI\_Level-1B\_Granule\_Metadata.xsd* included in the *S2-PDGS-TAS-DI-PSD-V14\_Schemas.zip* file annexed to the document.

- **IMG\_DATA (folder):**

The naming convention used to identify the image files contained in the IMG\_DATA folder is defined hereafter:

Image File naming convention = *<PDI\_ID\*>\_<Band\_Index>.jp2*

where:

Field Name	Value/Meaning	Note
<i>PDI_ID*</i>	PDI_ID without Processing Baseline sub-string	
<i>Band Index</i>	Bxx where: xx = 01, 02, 03, 04, 05, 06, 07, 08, 8A, 09, 10, 11, 12	Field identifying the spectral bands

IMG\_DATA/Level-1B image file template name:

*S2A\_OPER\_MSI\_L1B\_GR\_MTI\_20141104T134012\_S20141104T134012\_D11\_B08.jp2*

- **QI\_DATA (folder):**

QI\_DATA folder contains:

- XML reports *OLQC\_Report.xml* generated by On-Line Quality Control processor, including Quality Control Checks results. The *OLQC\_Report.xsd* schema and the reports naming convention are in the Annex D of the document.

File Template Name:

*S2A\_OPER\_MSI\_L1B\_GR\_MTI\_20141104T134012\_S20141104T134012\_D11\_GEOMETRIC\_QUALITY\_report.xml*

- Quality\_Masks (one for each type, GML/JPEG2000).

The naming used for the mask files follows the same convention defined for the L1B Granule ID (cf. section 3.4.2) except for the additional *<Product Type>* filed.

Mask files naming convention = MMM\_CCCC\_TTTTTTTTTT\_<Instance\_ID>.gml

L1B masks main file types (TTTTTTTTTT) are in the Table 18 and listed again hereafter

1. MSK\_CLOLOW (Coarse cloud mask files)
2. MSK\_TECQUA (Technical quality mask files)
3. MSK\_DEFECT (Radiometric quality masks)
4. MSK\_SATURA (Radiometric quality masks)
5. MSK\_NODATA (Radiometric quality masks)

<Instance\_Id> = <Site Centre>\_<Creation Date>\_<Sensing Time>\_<Detector ID>\_<Band ID>\_<Product\_Type>

Where <Site Centre>, <Creation Date>, <Sensing Time> and <Detector ID> are inherited from the L1B Granule ID, <Product Tipe> = "MSIL1B" and <Band ID>:

<i>Band ID</i>	Bxx where:  xx = 01, 02, 03, 04, 05, 06, 07, 08, 8A, 09, 10, 11, 12
----------------	---





Template masks filename are:

S2A\_OPER\_MSK\_TECQUA\_MTI\_\_20141104T134012\_S20141104T134012\_D11\_B08\_MSIL1B.gml  
 S2A\_OPER\_MSK\_SATURA\_MTI\_\_20141104T134012\_S20141104T134012\_D11\_B08\_MSIL1B.gml

The grouping strategy to have several masks in one physical GML file is described in the Annex E.

- **Inventory\_Metadata (XML file):**  
XML Inventory metadata file with fixed name *Inventory\_Metadata.xml*
- **manifest.safe (XML file):**  
XML file with fixed name *manifest.safe*
- **rep\_info (folder):**  
Folder containing the following XSD schemas:
  1. S2\_PDI\_Level-1B\_Granule\_Metadata.xsd
  2. Inventory\_Metadata.xsd
  3. OLQC\_Report.xsd

Level-1B Granule Physical Format template:

<b>Level-1B Granule PDI_ID:</b> <b>S2A_OPER_MSI_L1B_GR_MTI__20141104T134012_S20141104T134012_D11_N05.22</b>
 <i>Inventory_Metadata.xml</i>  S2A_OPER_MTD_L1B_GR_MTI__20141104T134012_S20141104T134012_D11.xml  <i>manifest.safe</i>  IMG_DATA

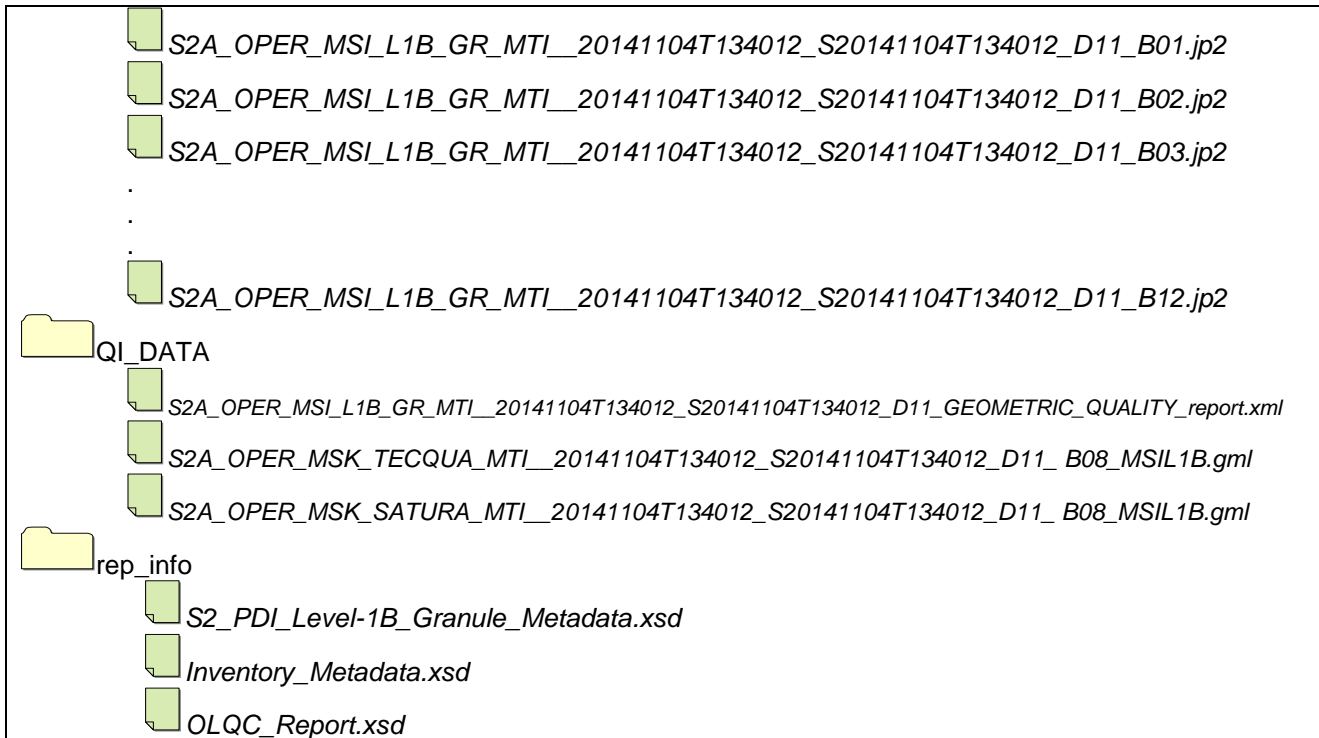
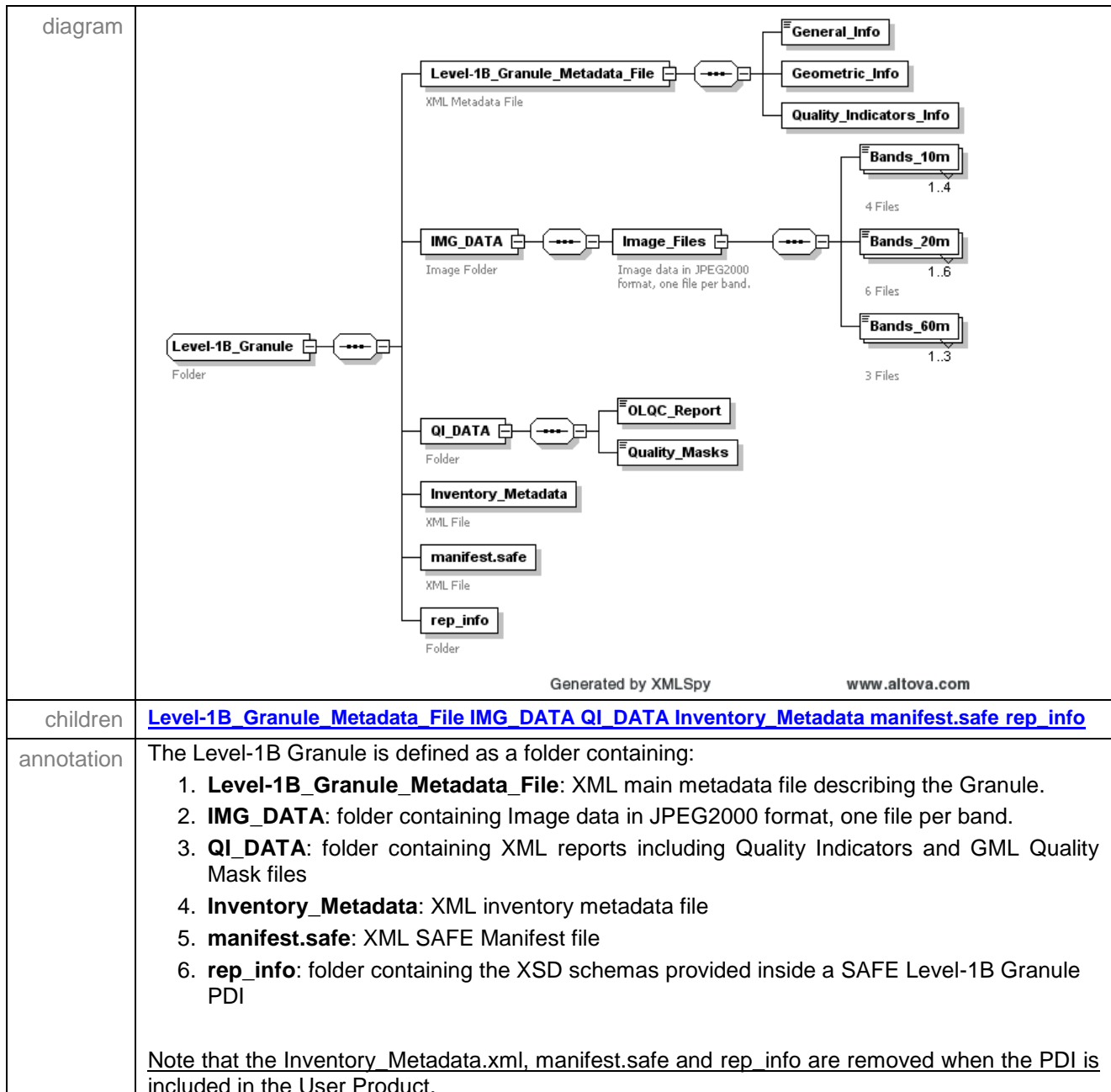

Figure 38: PDI Level-1B Granule Physical Format

### 3.9.3 Level-1B Granule PDI Structure

The *S2\_PDI\_Level-1B\_Granule\_Structure.xsd* schema annexed to the document and shown in the following diagram, represents the organization of a Level-1B Granule PDI on disk. This schema is provided for information only as It is actually not expected to be used for the validation of a XML file. The diagram reflects exactly the Figure 37.



### 3.9.3.1 Level-1B\_Granule\_Metadata\_File Schema

Level-1B\_Granule\_Metadata\_File is the XML metadata file provided inside each Level-1B Granule. The schema used to validate it is *S2\_PDI\_Level-1B\_Granule\_Metadata.xsd* annexed to this document. A detailed description of the schema is given here but for specific details regarding each metadata (e.g. type, default value, fixed value, enumerations, occurrences, etc...) refers to the XSD file.

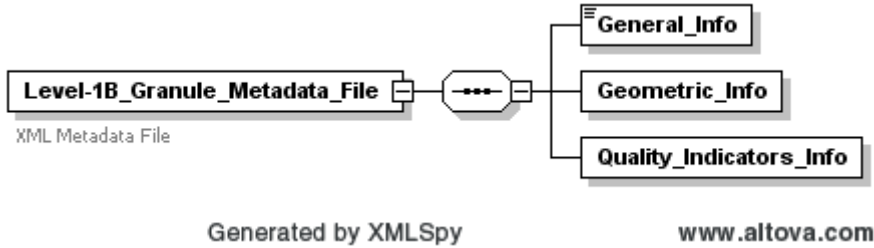
diagram	
children	<a href="#">General_Info</a> <a href="#">Geometric_Info</a> <a href="#">Quality_Indicators_Info</a>
annotation	<p>The Level-1B_Granule_Metadata_File is an XML file containing metadata regarding:</p> <ol style="list-style-type: none"> <li>1. <b>General_Info</b>: this group of metadata provides general information regarding the Granule.</li> <li>2. <b>Geometric_Info</b>: these metadata provide information describing the geolocation of the Granule.</li> <li>3. <b>Quality_Indicators_Info</b>: this metadata values provide information about image content quality indicators and quality control checks information.</li> </ol>

The following figures and tables give a complete overview of the Level-1B\_Granule\_Metadata\_File schema according the description provided in the section 3.4.1.

#### General Info:

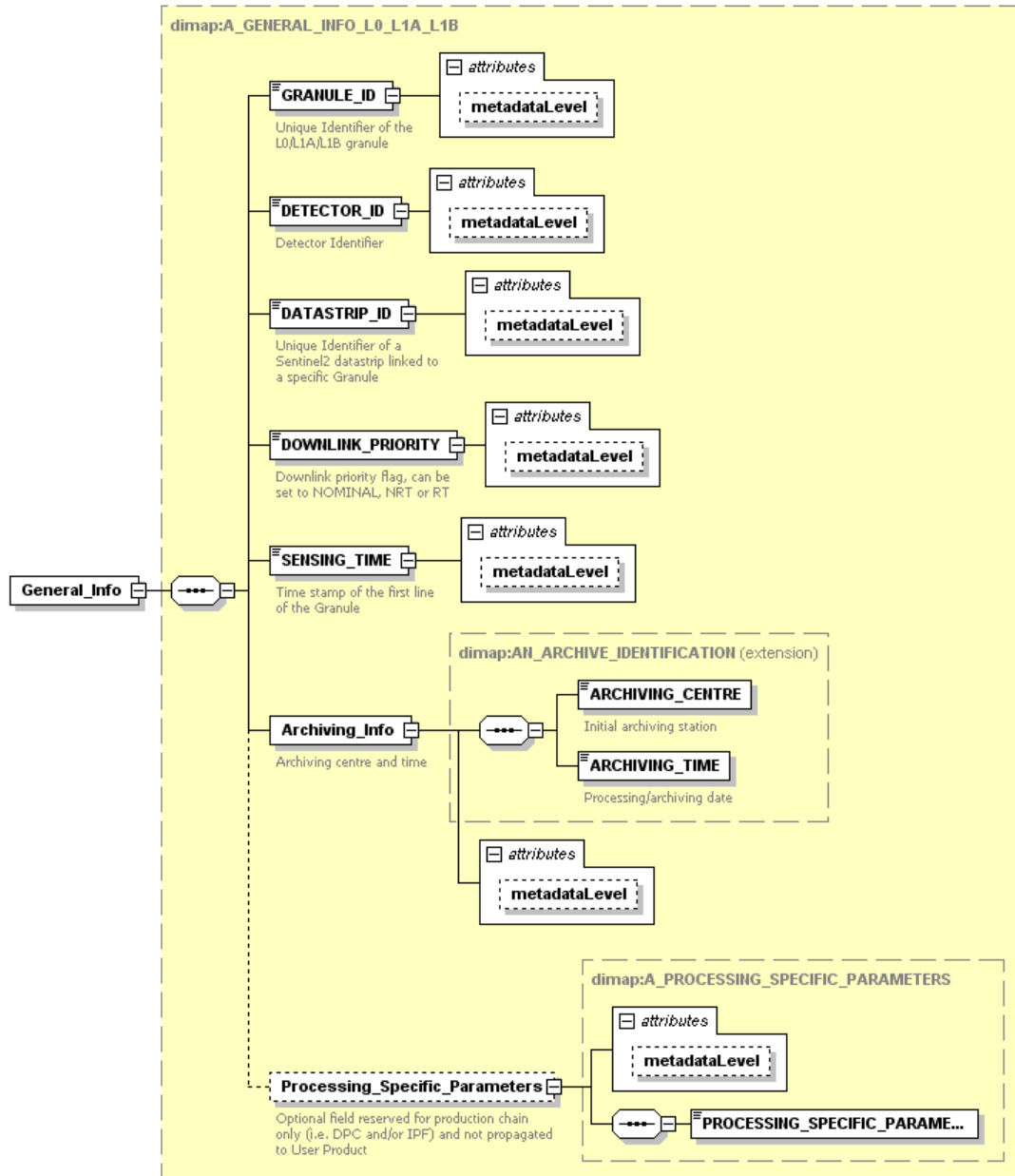

Generated by XMLSpy

www.altova.com

Figure 39: Level-1B\_Granule\_Metadata\_File - General\_Info Diagram





## Sentinel-2 Products Specification Document

REF : S2-PDGS-TAS-DI-PSD  
ISSUE : 14.5  
DATE : 14/03/2018  
PAGE : 209 / 510

General Info		
Field Name	Description	Metatada Level
GRANULE_ID	Granule_Identifier metadata indicates the unique identifier of the Level-1B Granule. This parameter coincides with PDI_ID definition described in section 3.5.6 and univocally points a Granule PDI in the archive.	Brief
DETECTOR_ID	Detector identifier corresponding to the Granule	Brief
DATASTRIP_ID	Unique identifier of the L1B Datastrip PDI linked to L1A Granule PDI. This parameter coincides with the PDI_ID of the PDI Datastrip linked to the Granule. This link establishes the hierarchy Granule vs Datastrip (cf. section 3.3)	Brief
DOWNLINK_PRIORITY	Downlink priority flag. It can be set Nominal/NRT/RT.	Standard
SENSING_TIME	<p>Time stamp of the first line of the Granule, that is the Sensing Start Time of the Granule PDI.</p> <p>Note: for L1A Granule the first line timing shall be taken from one reference band due to the coarse registration applied at Level 1A which makes the first line time different amongst the bands.</p>	Standard





**Sentinel-2 Products  
Specification Document**

REF : S2-PDGS-TAS-DI-PSD  
 ISSUE : 14.5  
 DATE : 14/03/2018  
 PAGE : 210 / 510

Archiving_Info/ARCHIVING_CENTRE	The starting point of the circulation data. The allowed values are: <ul style="list-style-type: none"> <li>• SGS_</li> <li>• MPS_</li> <li>• MTI_</li> <li>• EPA_</li> <li>• UPA_</li> <li>• CDAM</li> <li>• MPC_</li> </ul>	Expertise
Archiving_Info/ARCHIVING_TIME	Processing/archiving date (UTC data time)	Expertise
Processing_Specific_Parameters/ PROCESSING_SPECIFIC_PARAMETERS	Optional field reserved for production chain only (NOT propagated to User Product)	Expertise

Table 50: Level-1B\_Granule\_Metadata\_File - General\_Info Description



## Geometric Info:

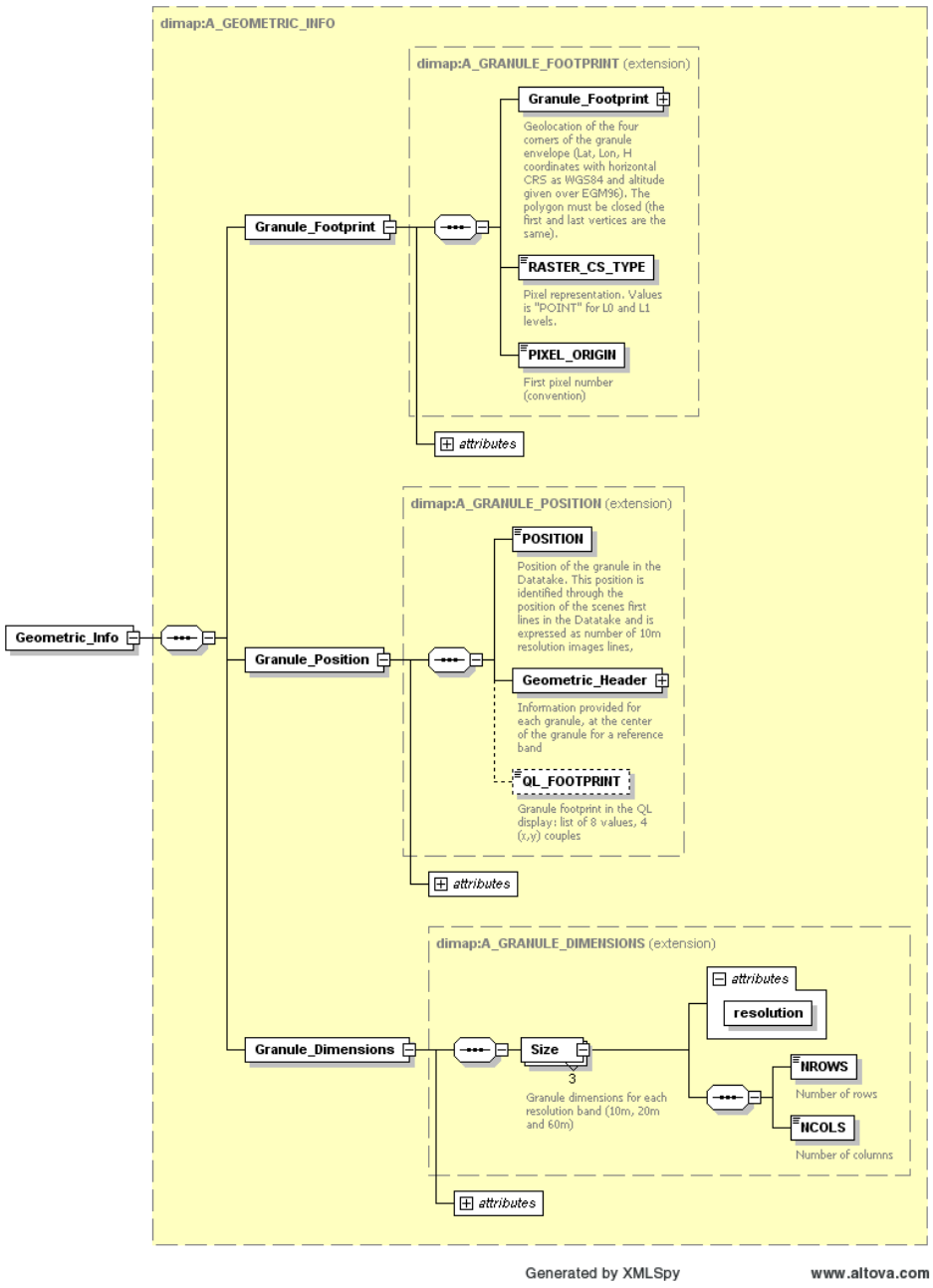

Figure 40: Level-1B\_Granule\_Metadata\_File - Geometric\_Info Diagram



**Sentinel-2 Products  
Specification Document**

REF : S2-PDGS-TAS-DI-PSD  
 ISSUE : 14.5  
 DATE : 14/03/2018  
 PAGE : 212 / 510

<b>Geometric_Info/Granule_Footprint</b>		
<b>Field Name</b>	<b>Description</b>	<b>Metatada Level</b>
Granule_Footprint	Granule geolocation updated for the Level-1B Granules (same information as Level-1A updated for Level-1B Granules).	Brief
RASTER_CS_TYPE	Pixel representation. Values is "POINT" for L0 and L1 levels.	Brief
PIXEL_ORIGIN	First pixel number (convention)	Brief
<b>Geometric_Info/Granule_Position</b>		
<b>Field Name</b>	<b>Description</b>	<b>Metatada Level</b>
Position	Position of the Granule in the Datatke (from Level-1A Granule Standard metadata),	Standard
Geometric_Header/GROUND_CENTER	Updated geometric header for the Level-1B Granules (same information as Level-1A updated for Level-1B Granules).  Information provided for a reference band, at the centre of the Granule, for each Granule. Geolocation of the Granule centre (Lat, Lon, H) Altitude is provided over the geoid.	Standard
Geometric_Header/QL_CENTER	Updated geometric header for the Level-1B Granules (same information as Level-1A updated for Level-1B Granules).  The Granule centre in the QL display: 1 (r,c) point.	Standard
Geometric_Header/Incidence_Angles	Updated geometric header for the Level-1B Granules (same information as Level-1A updated for Level-1B Granules).  Information provided for a reference band, at the centre of the Granule, for each Granule.	Standard



	Incidence angles corresponding to the centre of the Granule.	
Geometric_Header/Solar_Angles	Updated geometric header for the Level-1B Granules (same information as Level-1A updated for Level-1B Granules).  Information provided for a reference band, at the centre of the Granule, for each Granule. Solar angles corresponding to the centre of the Granule.	Standard
QL_FOOTPRINT	Granule footprint in the QL display: list of 8 values, 4 (x,y) couples.  Note: For L1B Granule this metadata is NOT mandatory.	Standard
<b>Geometric_Info/Granule_Dimension</b>		
<b>Field Name</b>	<b>Description</b>	<b>Metatada Level</b>
Size	Granule dimensions provided for each resolution band (10m, 20m and 60m)	Standard

Table 51: Level-1B\_Granule\_Metadata\_File - Geometric\_Info Description

Quality Indicators Info:

The Quality Indicators provided for a L1B Granule PDI are the same as for L1A.

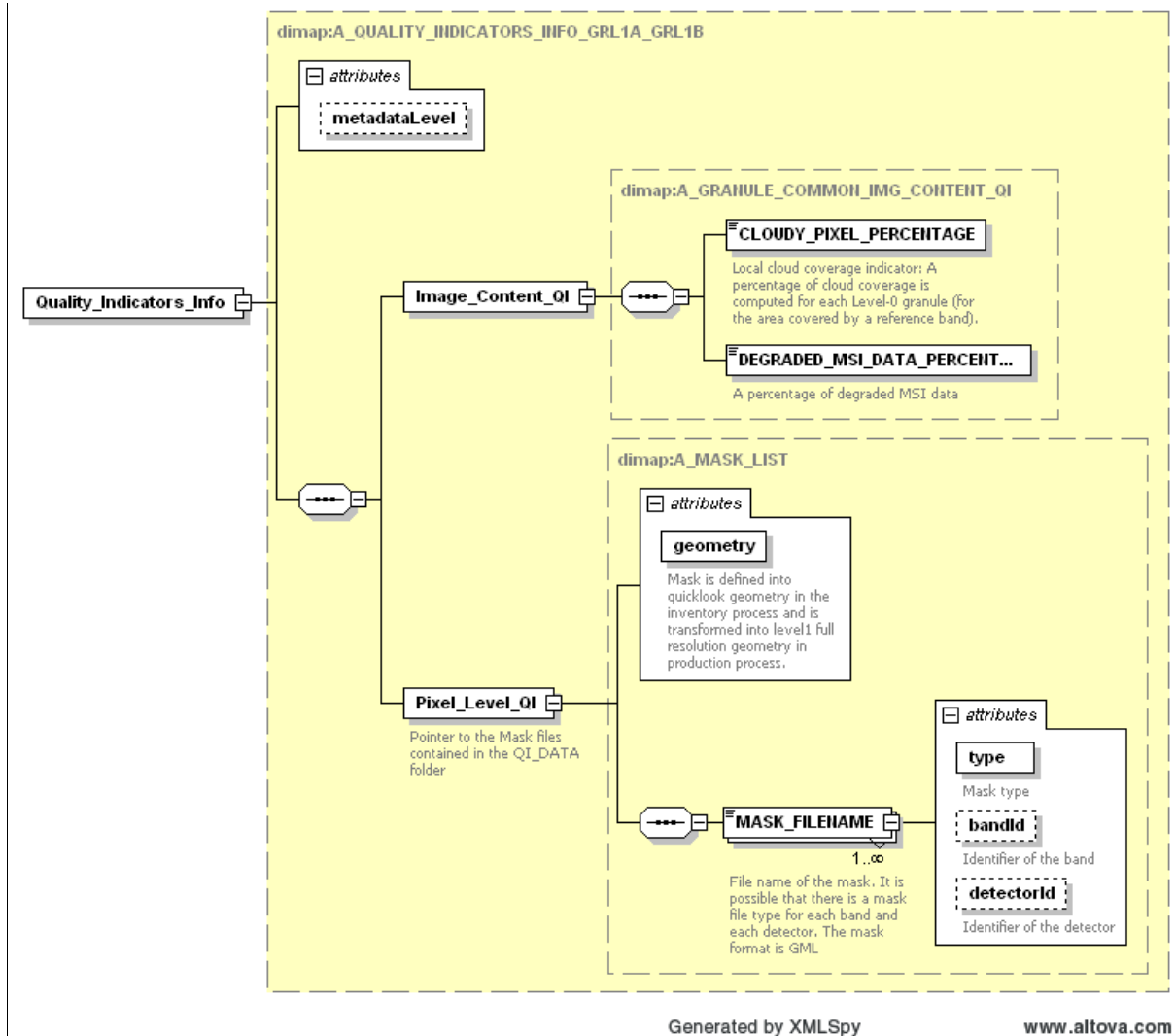

Figure 41: Level-1B\_Granule\_Metadata\_File – Quality\_Indicators\_Info Diagram

According to the content of the Table 3-4, the following table describes the Quality Indicators provided for a Level-1B Granule PDI.

Quality_Indicators_Info/Image_Content_QI		
Field Name	Description	Metatada Level
CLOUDY_PIXEL_PERCENTAGE	Local cloud coverage indicator: A percentage of cloud coverage is computed for each Level-1B Granule (for the area covered by a reference band).	Standard
DEGRADED_MSI_DATA_PERCENTAGE	Local technical quality indicator: A percentage of degraded MSI data is provided for each Level-1B Granule.	Standard
Quality_Indicators_Info/Pixel_Level_QI		
Field Name	Description	Metatada Level
MASK_FILENAME	Pointer to the mask files contained in the QI_DATA folder: <ul style="list-style-type: none"> <li>- Coarse cloud mask files</li> <li>- Technical quality mask files</li> <li>- Radiometric quality masks</li> </ul>	Standard

Table 52: Level-1B\_Granule\_Metadata\_File – Quality\_Indicators\_Info Description

Note that, according to OLQC procedures consolidation, the results of all quality control checks performed by OLQC processor on Level-1B Granule, are included in the XML reports stored in the QI\_DATA folder (cf. section 3.4.1, Table 19).

### 3.9.3.2 IMG\_DATA

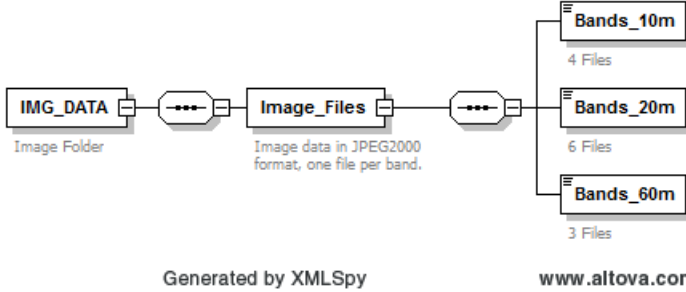
diagram	 <p align="center">Generated by XMLSpy <span style="float:right">www.altova.com</span></p>
children	<a href="#">Image_Files</a>
annotation	Folder containing image data compressed using the JPEG2000 algorithm, one file per spectral band (13 files).

### 3.9.3.3 QI\_DATA

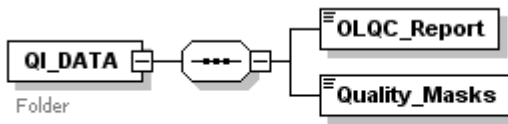
diagram	 <p align="center">Generated by XMLSpy <span style="float:right">www.altova.com</span></p>
children	<a href="#">OLQC_Report Quality_Masks</a>
annotation	QI_DATA folder contains the XML reports including the quality control checks performed by OLQC processor and the GML quality masks. The Annex C contains the description of OLQC reports and the masks files are listed in the Table 18.

### 3.9.4 SAFE Manifest synoptic table

The content of the SAFE Manifest for the Level-1B Granule PDI level, is the same as for the Level-1A Granule PDI level (except for a few specific text string in the “processing” section) and can be exhaustively described through Table 31, Table 43and Table 33.



### 3.10 Level-1B Datastrip PDI definition

Level-1B Datastrip PDI is defined as a **tar** file containing the following structure:

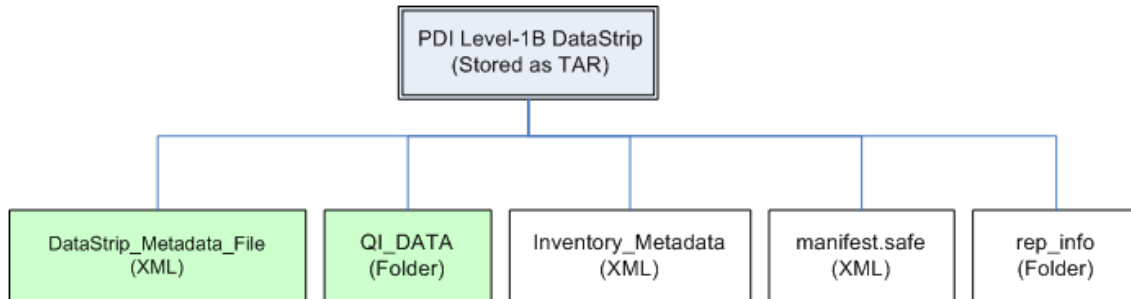

Figure 42: PDI Level-1B Datastrip Structure

The PDI Level-1B Datastrip consists of:

1. **Datastrip\_Metadata\_File**: XML metadata file containing the requested level of information and referring all the product elements composing the Datastrip,
2. **QI\_DATA**: folder containing XML reports including Quality control checks information,
3. **Inventory\_Metadata.xml**: file containing the metadata needed to inventory the PDI,
4. **manifest.safe**: XML SAFE Manifest file(mandatory, cf. section 3.5.4),
5. **rep\_info**: folder containing the available XSD schemas that validate the PDI components (recommended by [SAFE-SPEC], cf. section 3.5.4).

#### 3.10.1 PDI\_ID definition

Datastrip PDI\_ID (Datastrip ID) is defined in the section 3.5.2. The File\_Type is specified in the section 3.2, Table 5.

Level-1B Datastrip Template Name (Datastrip ID):

*S2A\_OPER\_MSI\_L1B\_DS\_SGS\_\_20141104T134012\_S20141104T134012\_N10.10.tar*

Note that the PDI\_ID.tar is the physical name of the Datastrip PDI after the tar compression.

### 3.10.2 Level-1B Datastrip Physical Format

The PDI ID defined above represents the “Datastrip directory” name. Inside the Datastrip directory, there are the Datastrip components as in the Figure 42:

Inside that directory, the naming convention used to identify each real files follows the same convention used to define the Datastrip ID but without the Processing Baseline sub-string.

- **Datastrip\_Metadata\_File (XML file):**

Datastrip\_Metadata\_File template name:

*S2A\_OPER\_MTD\_L1B\_DS\_SGS\_\_20141104T134012\_S20141104T134012.xml*

The XSD schema which regulates the metadata file is *S2\_PDI\_Level-1B\_Datastrip\_Metadata.xsd* included in the *S2-PDGS-TAS-DI-PSD-V14\_Schemas.zip* file annexed to the document.

- **QI\_DATA (folder):**

QI\_DATA folder contains:

– XML reports *OLQC\_Report.xml* generated by On-Line Quality Control processor, including Quality Control Checks results. The *OLQC\_Report.xsd* schema and the reports naming convention are in the Annex C of the document.

File Template Name:

*S2A\_OPER\_MSI\_L1B\_DS\_SGS\_\_20141104T134012\_S20141104T134012\_GEOMETRIC\_QUALITY\_report.xml*

- **Inventory\_Metadata (XML file):**







XML Inventory metadata file with fixed name *Inventory\_Metadata.xml*

- **rep\_info (folder):**

Folder containing the following XSD schemas:

1. *S2\_PDI\_Level-1B\_Datastrip\_Metadata.xsd*
2. *Inventory\_Metadata.xsd*
3. *OLQC\_Report.xsd*

Level-1B Datastrip Physical Format template:

Level-1B Datastrip PDI_ID: <i>S2A_OPER_MSI_L1B_DS_SGS__20141104T134012_S20141106T134012_N10.10</i>	
	<i>Inventory_Metadata.xml</i>
	<i>S2A_OPER_MTD_L1B_DS_SGS__20141104T134012_S20141104T134012.xml</i>
	<i>manifest.safe</i>
	QI_DATA
	<i>S2A_OPER_MSI_L1B_DS_SGS__20141104T134012_S20141104T134012_GEOMETRIC_QUALITY_report.xml</i>
	rep_info



*S2\_PDI\_Level-1B\_Datastrip\_Metadata.xsd*  
*Inventory\_Metadata.xsd*  
*OLQC\_Report.xsd*

Figure 43: PDI Level-1B Datastrip Physical Format

### 3.10.3 Level-1B Datastrip PDI Structure

The *S2\_PDI\_Level-1B\_Datastrip\_Structure.xsd* schema annexed to the document and shown in the following diagram, represents the organization of a Level-1B Datastrip PDI on. This schema is provided for information only as It is actually not expected to be used for the validation of a XML file. The diagram reflects exactly the Figure 42.

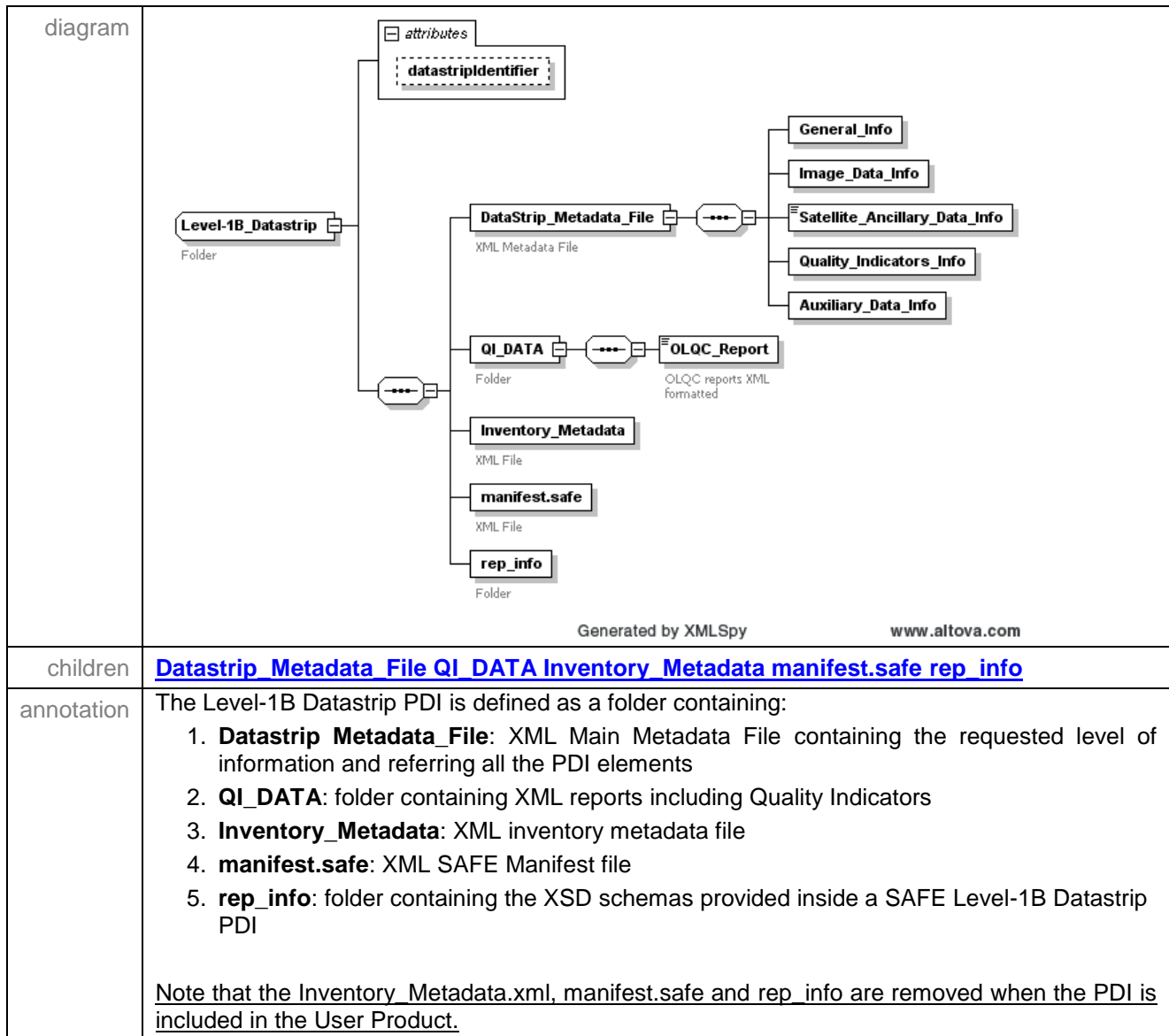

#### 3.10.3.1 Datastrip\_Metadata\_File Schema

Level-1B Datastrip\_Metadata\_File is the XML metadata file provided inside each Level-1B Datastrip. The schema used to validate it is *S2\_PDI\_Level-0\_Datastrip\_Metadata.xsd* annexed to

this document. A detailed description of the schema is given here but for specific details regarding each metadata (e.g. type, default value, fixed value, enumerations, occurrences, etc...) refers to the XSD file.

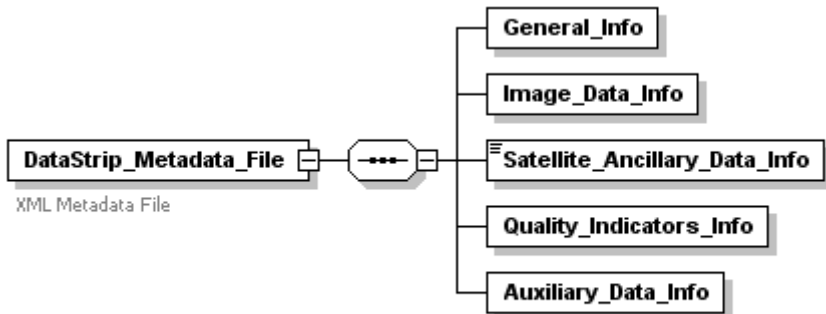
<p>diagram</p>	 <p align="center">Generated by XMLSpy <span style="float:right">www.altova.com</span></p>
<p>children</p>	<p><a href="#">General_Info</a> <a href="#">Image_Data_Info</a> <a href="#">Satellite_Ancillary_Data_Info</a> <a href="#">Quality_Indicators_Info</a> <a href="#">Auxiliary_Data_Info</a></p>
<p>annotation</p>	<p>The structure of the Datastrip_Matadata_File is common to all processing level (cfr. § 3.5.1) The Datastrip_Metadata_File is an XML file containing all the metadata describing the whole product data item.</p> <ol style="list-style-type: none"> <li>1. <b>General_Info</b>: This group of metadata provide general information characterizing the source Datastrip acquisition.</li> <li>2. <b>Image_Data_Info</b>: Image data information from MSI telemetry.</li> <li>3. <b>Satellite_Ancillary_Data_Info</b>: Ancillary data information from Satellite Ancillary Telemetry.</li> <li>4. <b>Quality_Indicators_Info</b>: Results of all quality checks performed at Datastrip level.</li> <li>5. <b>Auxiliary_Data_Info</b>: Auxiliary data information.</li> </ol>

The following tables and figures give a complete overview of the Level-1B Datastrip\_Metadata\_File schema according the description provided in the section 3.5.1.

General Info:

The General\_Info provided through the Level-1B DataSrip\_Metadata\_File are the same described in the Figure 20 and Table 3-32.

Image Data Info:

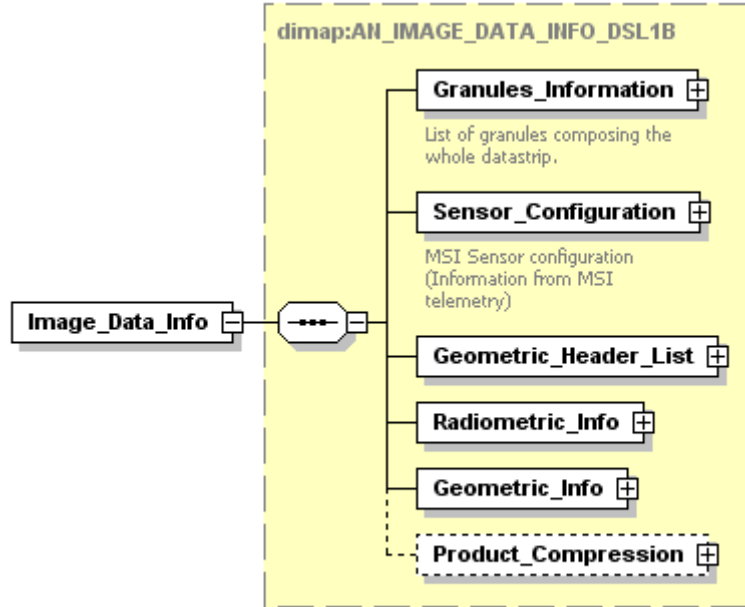

Generated by XMLSpy

www.altova.com

Figure 44 : Level-1B Datastrip – Image\_Data\_Info Diagram



**Sentinel-2 Products  
Specification Document**

REF : S2-PDGS-TAS-DI-PSD  
ISSUE : 14.5  
DATE : 14/03/2018  
PAGE : 223 / 510

Image_Data_Info/Granules_Information		
Field Name	Description	Metatada Level
/Detector_List/.../POSITION	This branch of the schema provides information regarding all Granules, for each detector, composing the whole Datastrip. Each Granule composing the Datastrip is univocally identified trough a unique Granule identifier (PDI_ID at granul level). For each Granule the Position of the Granule is provided. This position is identified through the position of the scenes first lines in the Datastrip and is expressed as number of 10m resolution images lines.	Standard
Image_Data_Info/Sensor_Configuration (inherited from Level-0 metadata)		
Field Name	Description	Metatada Level
Acquisition_Configuration/COMPRESS_MODE	Flag to indicate if compress mode is by passed	Expertise
Acquisition_Configuration/EQUALIZATION_MODE	Flag to indicate if equalization is active	Expertise
Acquisition_Configuration/NUC_TABLE_ID	In-flight Non Uniform Correction table ID defined by 10 bits. This ID is uniform for all transmitted bands. It identifies the correction coefficients table used in-flight	Expertise
Acquisition_Configuration/Active_Detectors_List	On board active Detectors (in case of compression by-passed)	Expertise
Acquisition_Configuration/ TDI_Configuration_List	On board TDI configuration, for B3, B4, B11 and B12 only.	Standard
Acquisition_Configuration/Spectral_Band_Info/PHYSICAL_GAIN	Physical Gain for each band	Standard
Acquisition_Configuration/Spectral_Band_Info/COMPRESSION_RATE	On-board compression rates for each band	Expertise
Acquisition_Configuration/Spectral_Band_Info/INTEGRATION_TIME	On-board integration time for each band	Expertise
Source_Packet_Description	Source packet information for each band	Standard
Time_Stamp/LINE_PERIOD	Line period for the acquisition of line of 10 m full-resolution image data	Standard
Time_Stamp/Band_Time_Stamp/Detector	Datation model for each couple band, detector.	Standard





**Sentinel-2 Products  
Specification Document**

REF : S2-PDGS-TAS-DI-PSD  
 ISSUE : 14.5  
 DATE : 14/03/2018  
 PAGE : 224 / 510

Time_Stamp/GPS_SYNC	Flag (Boolean) to indicate if MSI is synchronize with GPS time	Standard
Time_Stamp/THEORETICAL_LINE_PERIOD	Theoretical line period for the acquisition of line of 10 m full-resolution image data	Standard
Time_Stamp/Quality_Indicators	Optional. Created when datation models are estimated through linear regression.	Standard
<b>Image_Data_Info/Geometric_Header_List</b>		
<b>Field Name</b>	<b>Description</b>	<b>Metatada Level</b>
Geometric_Header_List	Geometric information  For all details see Table 35, section "Image_Data_Info/Geometric_Header_List"	Standard Expertise
<b>Image_Data_Info/Radiometric_Info</b>		
<b>Field Name</b>	<b>Description</b>	<b>Metatada Level</b>
SWIR_REARRANGEMENT_PROC	SWIR pixels re-arrangement (only for level 1A production but SWIR rearrangement information shall be preserved in L1B and L1C): A 'true' value indicates that data extraction and SWIR pixels re-arrangement have been processed.	Standard
Equalization	On ground equalization of the image using an optimized polynomed correction (only for level 1B production)	Standard
CROSSTALK_OPTICAL_PROC	Optical crosstalk correction (only for level 1B production). A 'true' value indicates that optical crosstalk correction has been processed.	Standard
CROSSTALK_ELECTRONIC_PROC	Electronic crosstalk correction (only for level 1B production). A 'true' value indicates that electronic crosstalk correction has been processed.	Standard
REMOVE_BLIND_PIXELS_PROC	Blind pixel remonving (only for level 1B production). A 'true' value indicates that Blind pixel remonving has been processed.	Standard







**Sentinel-2 Products  
Specification Document**

REF : S2-PDGS-TAS-DI-PSD  
 ISSUE : 14.5  
 DATE : 14/03/2018  
 PAGE : 225 / 510

DEFECTIVE_PIXELS_PROC	Defective pixels processing. A 'true' value indicates that defective pixels have been detected and processed, a 'detection' value indicates that defective pixels have been only detected (only for level 1A production), a 'false' value indicates that defective pixels have been neither detected nor processed.	Standard
Restoration	Restoration and levelling of the product to 12 bits (only for level 1B production)	Standard
BINNING_PROC	Binning for 60m bands (only for level 1B production). A 'true' value indicates that binning for 60m bands has been processed.	Standard
PIXELS_NO_DATA_PROC	Management of NO_DATA pixels. A 'true' value indicates that NO_DATA pixels have been detected and processed, a 'detection' value indicates that NO_DATA pixels have been only detected (only for level 1A production), a 'false' value indicates that NO_DATA pixels have been neither detected nor processed.	Standard
SATURATED_PIXELS_PROC	Management of saturated pixels. A 'true' value indicates that saturated pixels has been processed.	Standard
Spectral_Information_List/Spectral_Information/RESOLUTION	(OPTIONAL BRANCH)  Spectral filter information provided by the GIPP ABSOLUTE_CALIBRATION  Spatial resolution	Standard
Spectral_Information_List/Spectral_Information/Wavelength/MIN	Minimum wavelength	Standard
Spectral_Information_List/Spectral_Information/Wavelength/MAX	Maximum wavelength	Standard
Spectral_Information_List/Spectral_Information/Wavelength/CENTRAL	Central wavelength	Standard
Spectral_Information_List/Spectral_Information/Spectral_Response/STEP	Step of spectral response	Standard
Spectral_Information_List/Spectral_Information/Spectral_Response/VALUES	List of measures	Standard
Image_Display_Order/RED_CHANNEL	Relation between product image channels and on board spectral bands (Band index).	Brief
Image_Display_Order/GREEN_CHANNEL	Relation between product image channels and	Brief





**Sentinel-2 Products  
Specification Document**

REF : S2-PDGS-TAS-DI-PSD  
 ISSUE : 14.5  
 DATE : 14/03/2018  
 PAGE : 226 / 510

	on board spectral bands (Band index).	
Image_Display_Order/BLUE_CHANNEL	Relation between product image channels and on board spectral bands (Band index).	Brief
<b>Image_Data_Info/Geometric_Info</b>		
<b>Field Name</b>	<b>Description</b>	<b>Metatada Level</b>
RGM	Flag to identify if the Refined Geometric Model File is computed or obtained from a existing RGMF (reused)	Standard
Image_Refining	Refining results. Should exist only if REFINING_TYPE= REFINING or REFINING_REGISTRATION	Standard
VNIR_SWIR_Registration	Registration results. Should exist only if REFINING_TYPE= REGISTRATION or REFINING_REGISTRATION	Standard
Refined_Corrections_List	Description of the refined corrections. If the refining has been processed by Datastrip then, there are the refined corrections for each Datastrip. These data are created by Geo_S2.	Standard
<b>Image_Data_Info/Product_Compression (OPTIONAL BRANCH)</b>		
<b>Field Name</b>	<b>Description</b>	<b>Metatada Level</b>
COMPRESSION	Product Compression.  The compression may be: - None. - LOSSLESS: Lossless compression, use reversible JPEG2000 compression. - LOSSY: Lossy compression, use compression that ensures that JPEG2000 compression has a negligible effect on image quality.	Standard

Table 53: Level-1B Datastrip – Image\_Data\_Info Description



Satellite Ancillary Data Info:

The Satellite\_Ancillary\_Data\_Info are the same provided with a L0 Datastrip (cfr. Figure 22 and Table 36)

Quality Indicators Info:

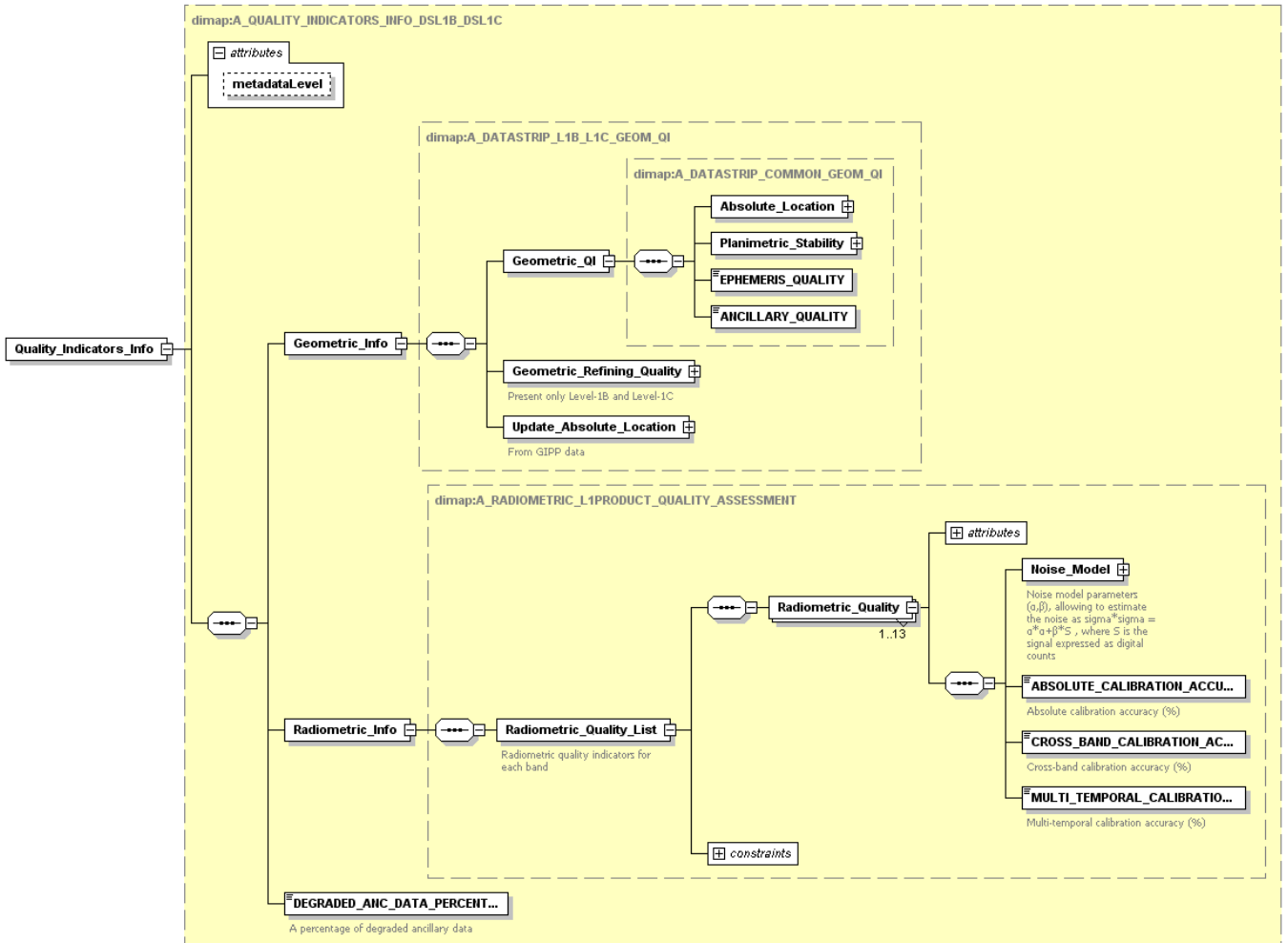

Generated by XMLSpy

www.altova.com

Figure 45: Level-1B Datastrip – Quality\_Indicators\_Info Diagram



**Sentinel-2 Products  
Specification Document**

REF : S2-PDGS-TAS-DI-PSD  
ISSUE : 14.5  
DATE : 14/03/2018  
PAGE : 228 / 510

Quality_Indicators_Info/Geometric_Info		
Field Name	Description	Metadata Level
Geometric_QI/Absolute_Location	Absolute location performance for the Datastrip given from a GIPP table, depending on the health status of the GPS and AOCS sensors (gyros and startrackers) provided in the Satellite Ancillary Data.	Brief
Geometric_QI/Planimetric_Stability	A planimetric stability performance for the Datastrip given from a GIPP table, depending on the health status of the GPS and AOCS sensors (gyros and startrackers) provided in the Satellite Ancillary Data.	Brief
Geometric_QI/EPHEMERIS_QUALITY	Ephemeris data quality retrieved from GPS Dilution of precision (DOP) information.	Brief
Geometric_QI/ANCILLARY_QUALITY	Ancillary data quality retrieved from GPS Dilution of precision (DOP) information.	Brief
Geometric_Refining_Quality	Available by Datastrip and only if geometric refining is applied. Include Multi_Spectral_Registration performance (3 values for 10, 20 and 60m bands (from GIPP data).	Brief
Update_Absolute_Location	From GIPP data	Brief
Quality_Indicators_Info/Radiometric_Info		
Field Name	Description	Metadata Level
Noise_Model	Alpha and Beta parameters providing the instrument noise as a function of the radiometric count X for Level-1B : Noise= square root(Alpha_X + Beta_X* X)	Brief





**Sentinel-2 Products  
Specification Document**

REF : S2-PDGS-TAS-DI-PSD  
ISSUE : 14.5  
DATE : 14/03/2018  
PAGE : 229 / 510

ABSOLUTE_CALIBRATION_ACCURACY	Absolute calibration accuracy provided as a percentage of accuracy	Brief
CROSS_BAND_CALIBRATION_ACCURACY	Cross-band calibration accuracy provided as a percentage of accuracy	Brief
MULTI_TEMPORAL_CALIBRATION_ACCURACY	Multi-temporal calibration accuracy provided as a percentage of accuracy	Brief
DEGRADED_ANC_DATA_PERCENTAGE	Percentage of degraded ancillary data	Brief

Table 54: Level-1B Datastrip – Quality\_Indicators\_Info Description



Auxiliary Data Info:

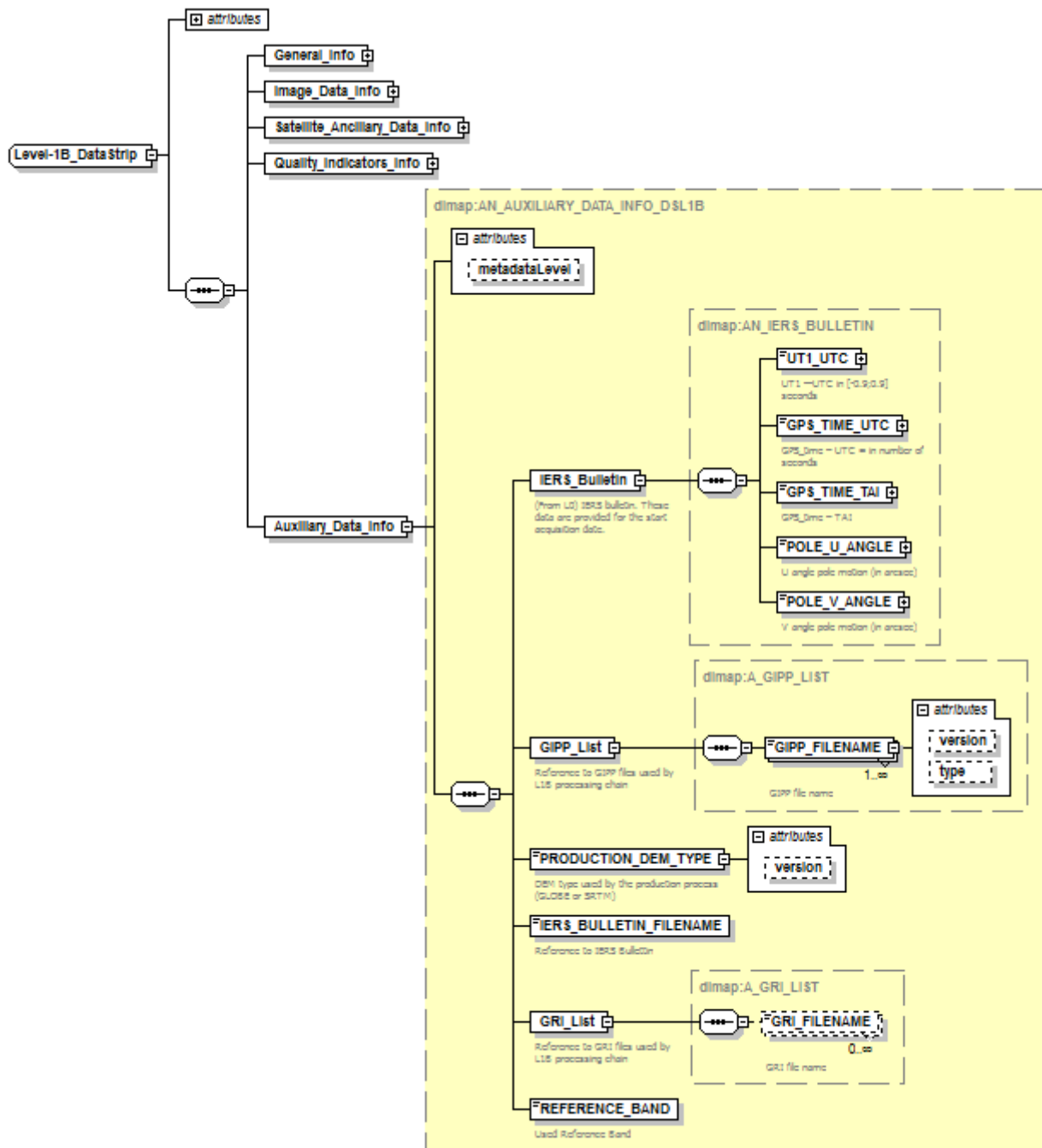

Generated by XMLSpy

www.altova.com

Figure 46 : Level-1B Datastrip – Auxiliary\_Data\_Info Diagram



## Sentinel-2 Products Specification Document

REF : S2-PDGS-TAS-DI-PSD  
ISSUE : 14.5  
DATE : 14/03/2018  
PAGE : 231 / 510

Auxiliary_Data_Info/IERS_Bulletin (aux info from Level-1A)		
Field Name	Description	Metatada Level
UT1.UTC	UT1 --UTC in [-0.9;0.9] seconds	Standard
GPS_TIME.UTC	GPS_time – UTC = in number of seconds	Standard
GPS_TIME.TAI	GPS_time – TAI	Standard
POLE_U.ANGLE	U angle pole motion (in arcsec)	Standard
POLE_V.ANGLE	V angle pole motion (in arcsec)	Standard
Auxiliary_Data_Info (aux data used by the processing)		
Field Name	Description	Metatada Level
GIPP_FileName	Reference to the GIPP files used by the L1B processing.	Standard
PRODUCTION_DEM_TYPE	DEM type used by the production process (GLOBE or SRTM)	Standard
IERS_BULLETIN_FILENAME	Reference to the used IERS Bulletin	Standard
GRI_FILENAME	Reference to the used GRI data	Standard
Auxiliary_Data_Info (others aux info)		
Field Name	Description	Metatada Level
REFERENCE_BAND	Used reference band	Standard

Table 55: Level-1B Datastrip – Auxiliary\_Data\_Info Description

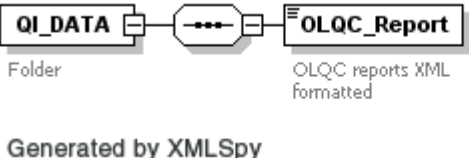

### 3.10.3.2 QI\_DATA

diagram	 <p>Generated by XMLSpy <a href="http://www.altova.com">www.altova.com</a></p>
children	<a href="#">OLQC_Report</a>
annotation	<p>QI_DATA folder contains:</p> <ul style="list-style-type: none"> <li>- XML reports generated by On-Line Quality Control processor, including Quality Control Checks results. The Annex C contains the description of OLQC reports.</li> </ul>



### 3.10.4 SAFE Manifest synoptic table

This chapter provides a detailed description of the content of the SAFE Manifest for the Level-1B Datastrip PDI level.

The SAFE Manifest file is compliant to the SAFE specification (cf. [SAFE-SPEC]) and is composed (cf. section 3.4.4) by three main sections (Metadata, Information Package Map and Data Objects).

Part of the information contained in the Metadata section is extracted from the XML metadata file and is therefore duplicated in the SAFE Manifest and in the XML metadata file.

With reference to the three mentioned sections the chapter provides, as a guideline to the generation process of the SAFE Manifest file, the following elements:

- Table 31 describing the content and structure of the Information Package Map section; same consideration apply as in section 3.5.9;
- for the Metadata Section, a table that lists the fields (tags) composing the section, providing, for each field:
  - the field name in the SAFE Manifest file (column “SAFE Manifest”, divided into column “Metadata name”, containing the name of the Metadata section of the manifest to which the field belongs, and “Name of tag or attribute” containing the actual tag name or attribute name (for sake of clarity, attributes are written in bold characters))
  - the name of the corresponding tag (if available, else N.A.) of the XML Metadata File and of its XSD Schema (column “From S2\_PDI\_Level-1B\_Datastrip\_Metadata.xsd”);
  - a brief textual description of the field;
  - the data type of the field (e.g. string, string enum, integer, double, xs:dateTime etc.);
  - the occurrence of the field (min/man occurrence e.g. 0..1); a minimum occurrence of 1 means that the field is mandatory;
  - the allowed range of values of the field.

In particular, the satellite ancillary data files (e.g. the SAD Raw Data file) and the auxiliary data files used for Level-1B processing (e.g. GIPP files, DEM, IERS Bulletin), are external to the product and are referenced in the Metadata of Manifest file Section (as “resources” in the “processing” section).

- Table 33 describing the content and structure of the Data Objects section; consider that this section contains a reference to each file (Data files and Metadata files) composing the Level-1B PDI (with the exception of the Manifest file itself); this includes:
  - the XML Metadata file;
  - the XML Inventory\_Metadata file;
  - a set of Quality Indicator Data Files, including a OLQC Report file (XML format) and five Preliminary Quick Look files (in JPEG2000 format).



## Sentinel-2 Products Specification Document

REF : S2-PDGS-TAS-DI-PSD

ISSUE : 14.5

DATE : 14/03/2018

PAGE : 234 / 510

An example of Manifest file for the Level-1B Datastrip PDI containing realistic, though indicative values, is provided as annexed zip file to this document (S2-PDGS-TAS-DI-PSD-V14\_SAFE.zip).



SAFE Manifest		From <i>S2_PDI_Level-0_Datastrip_Metadata.xsd</i>	Description	Data Type	Occurrence	Allowed range of values
Metadata name	Name of tag or attribute (in bold)	Tag name				
platform						
	nssdcIdentifier	N.A.	Unique identifier of the platform, defined by the World Data center for Satellite Information (WDC-SI)		1	WDC is discontinued; this tag is set to a default value 0000-0000
	familyName	General_Info->Datatake_Info->SPACECRAFT_NAME	The mission name of the platform	string enum	0..1	Sentinel
	number	General_Info->Datatake_Info->SPACECRAFT_NAME	Sequence identifier of the platform among the mission	string enum	0..1	2A, 2B, 2C
	instrument->familyName	N.A.	The instrument name used for acquiring the product data	string enum	0..1	Multi-Spectral Instrument
	instrument-> <b>abbreviation</b>	N.A.	Abbreviation of the instrument name	string enum	0..1	MSI
	instrument->mode	N.A.	The mode of the instrument	string enum	0..1	Nominal_Observation Dark_Signal_Calibration Extended_Observation Absolute_Radiometry_Calibration Vicarious_Calibration Raw_Measurement Test_Mode
	instrument->mode-> <b>identifier</b>	General_Info->Datatake_Info->DATATAKE_TYPE	The identifier of the instrument mode	string enum	1	INS-NOBS INS-EOBS INS-DASC INS-ABSR INS-VIC INS-RAW

SAFE Manifest		From <i>S2_PDI_Level-0_Datastrip_Metadata.xsd</i>	Description	Data Type	Occurrence	Allowed range of values
Metadata name	Name of tag or attribute (in bold)	Tag name				
						INS-TST
processing			Textual description of the history of processings that lead to the current product and of all the relevant resources involved in the processing (facilities, software, applicable documents etc)		1	
	<b>name</b>	N.A.	Name of the Archiving process	string	0..1	Archiving of PDI Level-1B Datastrip Product
	<b>start</b>	General_Info->Archiving_Info->ARCHIVING_TIME	Archiving start date (UTC)	xs:dateTime	0..1	
	facility		Description of Origin Centre		0..*	
	facility-> <b>name</b>	N.A.	Extended name of Origin Centre	string	1	
	facility-> <b>organization</b>	N.A.	Organization to which the Origin center belongs	string	0..1	
	facility-> <b>site</b>	General_Info->Archiving_Info->ARCHIVING_CENTRE	The starting point of the circulation data	string enum	0..1	SGS_ MPS_ MTI_ EPA_ UPA_ CDAM_ MPC_
	facility-> <b>country</b>	N.A.	Country where Origin Centre is located	string	0..1	

SAFE Manifest		From <i>S2_PDI_Level-0_Datastrip_Metadata.xsd</i>	Description	Data Type	Occurrence	Allowed range of values
Metadata name	Name of tag or attribute (in bold)	Tag name				
	resource		Description of product being archived		0..*	
	resource-> <b>name</b>	N.A.	Name of the product being archived	string	1	
	resource-> <b>role</b>	N.A.	Role of the resource	string	1	PDI Level-1B Datastrip Product
	resource-> processing		Description of the L1A to L1B Processing		0..*	
	resource-> processing-> <b>name</b>		Name of the L1A to L1B Processing	string	0..1	Processing of Level-1A Datastrip product
	resource-> processing-> <b>start</b>	General_Info->Processing_Info->UTC_DATE_TIME	Processing start date (UTC)	xs:dateTime	0..1	
	resource-> processing-> facility	N.A.	Description of Processing Centre		0..*	
	resource-> processing-> facility-> <b>name</b>	N.A.	Extended name of Origin Centre	string	1	
	resource-> processing-> facility-> <b>organization</b>	N.A.	Organization to which the Origin center belongs	string	0..1	
	resource-> processing-> facility-> <b>site</b>	General_Info->Processing_Info->PROCESSING_CENTER	Acronym of the Processing center	string enum	0..1	SGS_ MPS_ MTI_ EPA_ MPC_ UPA_ XXXX EDRS zzzL (zzz = first three characters of the LGS location)

SAFE Manifest		From <i>S2_PDI_Level-0_Datastrip_Metadata.xsd</i>	Description	Data Type	Occurrence	Allowed range of values
Metadata name	Name of tag or attribute (in bold)	Tag name				
	resource-> processing-> facility-> <b>country</b>	N.A.	Country where Origin Centre is located	string	0..1	
	resource-> processing-> facility->software		Description of software component used for Processing		0..*	
	resource-> processing-> facility->resource		List of auxiliary data files used by the processors to support radiometric and geometric correction (GIPP, DEM, GRI, IERS Bulletin etc.) and of SAD Raw Data file containing the satellite ancillary telemetry; these files are not provided with the product.		0..*	
	resource-> processing-> facility->resource-> <b>name</b>	Satellite_Ancillary_Data_Info->ANC_DATA_REF (reference to the folder containing the SAD Raw Data files) Auxiliary_Data_Info->IERS_Bulletin Auxiliary_Data_Info->GIPP_List->GIPP_FILENAME	Absolute path name of the auxiliary or ancillary file/folder	string	1	
	resource-> processing-> facility->resource-> <b>role</b>	N.A.	Role of the resource	string	1	Auxiliary data, Ancillary data
acquisitionPeriod					1	
	acquisitionPeriod ->startTime	Datastrip->L1B_Datastrip_PDI_ID (substring <Sensing Time>, cf. section 3.5.6)	Reference time of acquisition of the Granule (corresponding to sensing	xs:dateTime	1	



**Sentinel-2 Products  
Specification Document**

REF : S2-PDGS-TAS-DI-PSD  
ISSUE : 14.5  
DATE : 14/03/2018  
PAGE : 239 / 510

SAFE Manifest		From <i>S2_PDI_Level-0_Datastrip_Metadata.xsd</i>	Description	Data Type	Occurrence	Allowed range of values
Metadata name	Name of tag or attribute (in bold)	Tag name				
			time of the first line of the PDI at Datastrip level, cf. section 3.5.6)			
measurementOrbitReference						
	orbitNumber	General_Info->Datatake_Info->DatatakeIdentifier (substring <AbsoluteOrbitNumber>)	Absolute orbit number		0..1	> 0
	orbitNumber->type	N.A.	Absolute orbit number type (possible values "start" or "stop"). Set to "start" since the absolute orbit number refers to the first line of the Datastrip		0..1	start
	orbitNumber->groundTrackDirection	General_Info->Datatake_Info->SENSING_ORBIT_DIRECTION	Direction of the ground track of the Sentinel-2 platform at the time corresponding to orbitNumber->type (start or stop)		0..1	ascending, descending
	relativeOrbitNumber	> General_Info->Datatake_Info->SENSING_ORBIT_NUMBER	Relative orbit number (within the cycle)		0..1	1 to 143
	relativeOrbitNumber->type	N.A.	Relative orbit number type (possible values "start" or "stop"). Set to "start" since the absolute orbit number refers to the first line of the Datastrip		0..1	start





**Sentinel-2 Products  
Specification Document**

REF : S2-PDGS-TAS-DI-PSD  
 ISSUE : 14.5  
 DATE : 14/03/2018  
 PAGE : 240 / 510

SAFE Manifest		From <i>S2_PDI_Level-0_Datastrip_Metadata.xsd</i>	Description	Data Type	Occurrence	Allowed range of values
Metadata name	Name of tag or attribute (in bold)	Tag name				
metadataComponents		N.A	A reference to all Metadata files included in the product (e.g. the XML Metadata file, the XML Inventory Metadata file)		2..4	
metadataComponentSchemas		N.A	A reference to the Schemas used to validate the Metadata files included in the product (e.g. the XML Metadata file Schema)		0..2	

Table 56 - Content of Metadata Section for PDI Level-1B Datastrip SAFE Manifest





### 3.11 Level-1C Tile PDI definition

Level-1C Tile PDI level is defined as a **tar** file with the following structure:

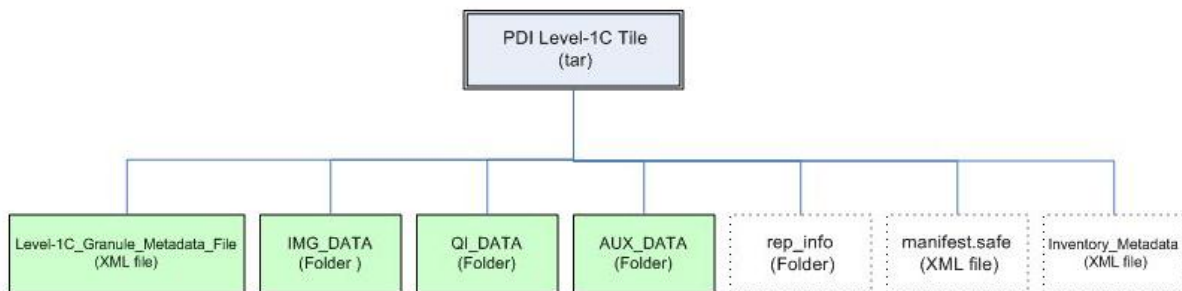

Figure 47: PDI Level-1C Tile Structure

The PDI Level-1C Tile consists of:

1. **Level-1C\_Tile\_Metadata\_File**: XML metadata file containing the requested level of information and referring all the product elements composing the Tile;
2. **IMG\_DATA**: folder containing image data files compressed using the JPEG2000 algorithm, one file per band;
3. **QI\_DATA**: folder containing XML reports including quality checks, GML mask files and JP2 PVI file;
4. **AUX\_DATA**: folder containing ECMWF data resampled in UTM projection;
5. **Inventory\_Metadata.xml**: file containing the metadata needed to inventory the PDI;
6. **manifest.safe**: XML SAFE Manifest file (mandatory, cf. section 3.11.4);
7. **rep\_info**: folder containing the available XSD schema that validate the PDI components (recommended by [SAFE-SPEC], cf. section 3.4.4).

#### 3.11.1 PDI\_ID definition

The PDI\_ID (Tile ID) used to identify a Level-1C Tile PDI, follows the description provided in the section 3.4.2. File\_Type is defined in the section 3.2, Table 5.

Level-1C Tile template name (Tile ID):

*S2A\_OPER\_MSI\_L1C\_TL\_MTI\_\_20141104T134012\_A123456\_T15SWC\_N11.11.tar*

Note that the PDI\_ID.tar is the physical name of the Tile PDI after the tar compression.

### 3.11.2 Level-1C Tile Physical Format

The PDI ID defined above represents the “Tile directory” name. Inside the Tile directory, there are the Tile components as in the Figure 47:

Inside that directory, the naming convention used to identify each real files, follows the same convention used in the section 3.11.1 (and US-MGRS naming convention as in section 4.9.2) to define the Tile ID but without the Processing Baseline sub-string.

- **Level-1C\_Tile\_Metadata\_File (XML file):**

Tile Metadata File Template:

*S2A\_OPER\_MTD\_L1C\_TL\_MTI\_20141104T134012\_A123456\_T15SWC.xml*

The XSD schema which regulates the metadata file is the *S2\_PDI\_Level-1C\_Tile\_Metadata.xsd* included in the *S2-PDGS-TAS-DI-PSD-V14\_Schemas.zip* file annexed to the document.

- **IMG\_DATA (folder):**

The naming convention used to identify the image files contained in the IMG\_DATA folder is defined hereafter:

Image File naming convention = <PDI\_ID\*>\_<Band\_Index>.jp2

where:

Field Name	Value/Meaning	Note
<i>PDI_ID</i>	PDI_ID without Processing Baseline sub-string	
<i>Band Index</i>	Bxx where: xx = 01, 02, 03, 04, 05, 06, 07, 08, 8A, 09, 10, 11, 12	Field identifying the spectral bands

IMA\_DATA/Level-1C image file template name:

*S2A\_OPER\_MSI\_L1C\_TL\_MTI\_20141104T134012\_A123456\_T15SWC\_B03.jp2*

- **QI\_DATA (folder):**

QI\_DATA folder contains:

- XML reports OLQC\_Report.xml generated by On-Line Quality Control processor, including Quality Control Checks results. The OLQC\_Report.xsd schema and the reports naming convention are in the Annex C of the document.
- Quality\_Masks (one for each type, GML/JPEG2000). The naming convention is defined below.
- PVI Preview Image file provided in ground geometry. The preview image is a single file in JPEG2000 format with GML geo-location information; it contains 3 visible-bands (490nm, 560nm, 665nm) in ground geometry at 320m resolution and in display order (RGB).

Mask files naming convention = MMM\_CCCC\_TTTTTTTTTT\_<Instance\_ID>.gml

L1C masks main file types (TTTTTTTTTT) are in the Table 18 and listed again hereafter

1. MSK\_CLOUDS (Finer cloud mask files)
2. MSK\_TECQUA (Technical quality mask files)
3. MSK\_DETFOO (Detector footprint mask files)
4. MSK\_DEFECT (Radiometric quality masks)
5. MSK\_SATURA (Radiometric quality masks)
6. MSK\_NODATA (Radiometric quality masks)

<Instance\_Id> = <Site Centre>\_<Creation Date>\_<Abs Orbit>\_<Tile>\_<Band ID>\_<Product\_Type>

Where <Site Centre>, <Creation Date>, <Abs Orbit> and <Tile> are inherited from the L1C Tile ID, <Product Tipe> = "MSIL1C" and <Band ID>:

<i>Band ID</i>	Bxx where:  xx = 01, 02, 03, 04, 05, 06, 07, 08, 8A, 09, 10, 11, 12 xx = 00 for mask file band independent
----------------	---

Template masks filename are:

*S2A\_OPER\_MSK\_CLOUDS\_MTI\_\_20141104T134012\_A123456\_T15SWC\_B00\_MSIL1C.gml*

The grouping strategy to have several masks in one physical GML file is described in the Annex E.

Preview Image naming convention = MMM\_CCCC\_TTTTTTTTTT\_<Instance\_ID>.jp2

PVI file type (TTTTTTTTTT) = PVI\_L1C\_TL

<Instance\_Id> = <Site Centre>\_<Creation Date>\_<Abs Orbit>\_<Tile>

MMM, CCCC and <Instance\_ID> are directly inherited from L1C Tile ID.

Template PVI filename:

*S2A\_OPER\_PVI\_L1C\_TL\_MTI\_\_20141104T134012\_A123456\_T15SWC.jp2*

- **AUX\_DATA (folder):**

This folder contains ECMWF data in UTM projection (single file in GRIB V1 format).

The naming convention is the same defined for ECMWF PDI with file type "AUX\_ECMWFT"

Template name:

*S2A\_OPER\_AUX\_ECMWFT\_PDMC\_YYYYMMDDTHMMSS\_VYYYYMMDDTHMMSS\_YYYYMMDDTHMMSS*

- **Inventory\_Metadata (XML file):**

XML Inventory metadata file with fixed name *Inventory\_Metadata.xml*

- **manifest.safe (XML file):**

XML file with fixed name *manifest.safe*

- **rep\_info (folder):**  
Folder containing the following XSD schemas:
  1. *S2\_PDI\_Level-1C\_Tile\_Metadata.xsd*
  2. *Inventory\_Metadata.xsd*
  3. *OLQC\_Report.xsd*

Level-1C Tile Physical Format template:



Figure 48: PDI Level-1C Tile Physical Format

3.11.3 Level-1C Tile PDI Structure

The *S2\_PDI\_Level-1C\_Tile\_Structure.xsd* schema annexed to the document and shown in the following diagram, represents the organization of a Level-1C Tile PDI on disk. This schema is provided for information only as It is actually not expected to be used for the validation of a XML file. The diagram reflects exactly the Figure 47.

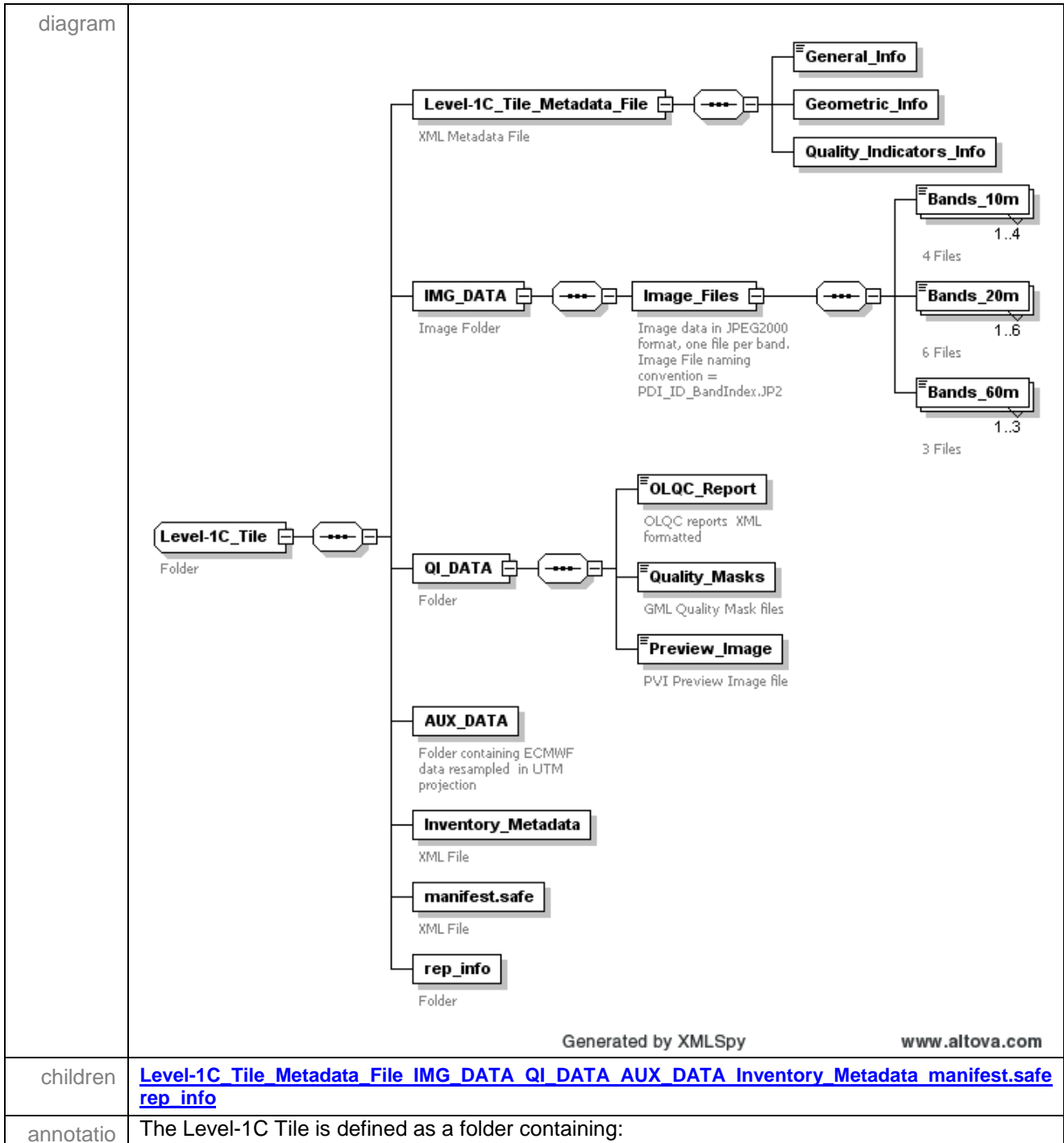

n

1. **Level-1C\_Tile\_Metadata\_File**: XML main metadata file describing the Granule.
2. **IMG\_DATA**: Folder containing Image data in GML JPEG2000 format, one file per band.
3. **QI\_DATA**: Folder containing XML reports including Quality Indicators, GML Quality Mask files and JP2 Preview Image file
4. **AUX\_DATA**: Folder containing ECMWF data resampled in UTM projection.
5. **Inventory\_Metadata**: XML inventory metadata file
6. **manifest.safe**: XML SAFE Manifest file
7. **rep\_info**: folder containing the XSD schemas provided inside a SAFE Level-1C Tile PDI

Note that the Inventory\_Metadata.xml, manifest.safe and rep\_info are removed when the PDI is included in the User Product.

### 3.11.3.1 Level-1C\_Tile\_Metadata\_File Schema

Level-1C\_Tile\_Metadata\_File is the XML metadata file provided inside each Level-1C Tile. The schema used to validate it is the *S2\_PDI\_Level-1C\_Tile\_Metadata.xsd* annexed to this document. A detailed description of the schema is given here but for specific details regarding each metadata (e.g. type, default value, fixed value, enumerations, occurrences, etc...) refers to the XSD file.

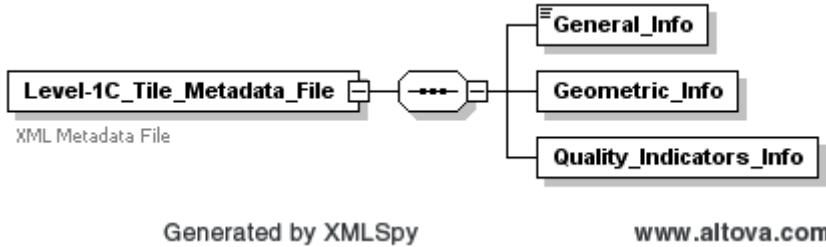
<p>diagram</p>	 <p align="center">Generated by XMLSpy <span style="float:right">www.altova.com</span></p>
<p>children</p>	<p><a href="#">General_Info</a> <a href="#">Geometric_Info</a> <a href="#">Quality_Indicators_Info</a></p>
<p>annotation</p>	<p>The Level-1C_Tile_Metadata_File is an XML file containing:</p> <ol style="list-style-type: none"> <li>1. <b>General_Info</b>: to provide general Tile information.</li> <li>2. <b>Geometric_Info</b>: to provide information regarding the Tile geolocation.</li> <li>3. <b>Quality_Indicators_Info</b>: to provide information about image content quality indicators and quality control checks information.</li> </ol>

The following figures and tables give a complete overview of the Level-1C\_Tile\_Metadata\_File schema according the description provided in the section 3.4.1.

#### General Info:

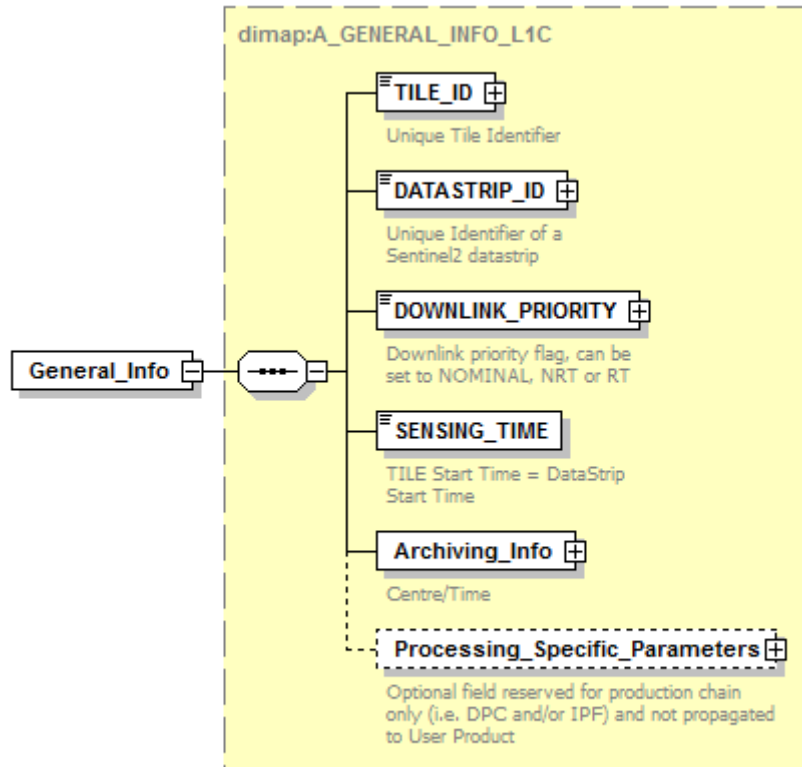

Generated by XMLSpy

www.altova.com

Figure 49: Level-1C\_Tile\_Metadata\_File - General\_Info Diagram





**Sentinel-2 Products  
Specification Document**

REF : S2-PDGS-TAS-DI-PSD  
 ISSUE : 14.5  
 DATE : 14/03/2018  
 PAGE : 249 / 510

General_Info		
Field Name	Description	Metatada Level
TILE_ID	TILE identifier (PDI_ID) defined in section 3.11.1 .	Brief
DATASTRIP_ID	Unique identifier of the L1C Datastrip PDI linked to the L1C Tile PDI. This parameter coincides with the PDI_ID of the PDI Datastrip linked to the Tile. This link establishes the hierarchy Tile vs Datastrip.	Standard
DOWNLINK_PRIORITY	Downlink priority flag. It can be set Nominal/NRT/RT.	Standard
SENSING_TIME	TILE Start Time. This value is currently set to the Datastrip Start Time (cf. datastrip definition in section 2.3 )  Note: set as Type date_time:AN UTC_DATE_TIME	Standard
Archiving_Info/ARCHIVING_CENTRE	The starting point of the circulation data. The allowed values are: <ul style="list-style-type: none"> <li>• SGS_</li> <li>• MPS_</li> <li>• MTL_</li> <li>• EPA_</li> <li>• UPA_</li> <li>• CDAM</li> <li>• MPC_</li> </ul>	Expertise
Archiving_Info/ARCHIVING_TIME	Processing/archiving date (UTC data time)	Expertise
Processing_Specific_Parameters/ PROCESSING_SPECIFIC_PARAMETERS	Optional field reserved for production chain only (NOT propagated to User Product)	Expertise

Table 57: Level-1C\_Tile\_Metadata\_File - General\_Info Description



Geometric Info:

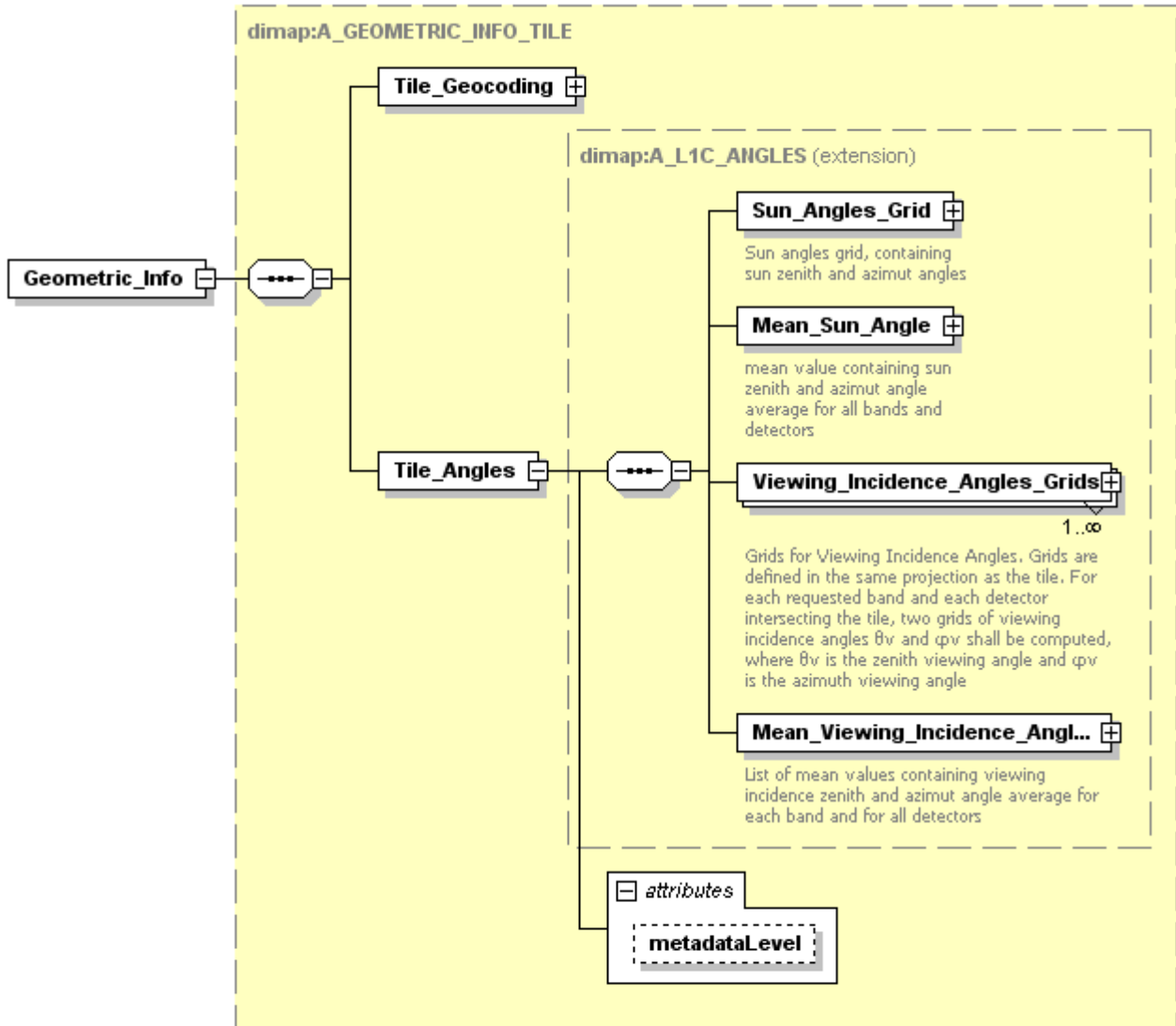

Generated by XMLSpy

www.altova.com

Figure 50: Level-1C\_Tile\_Metadata\_File - Geometric\_Info Diagram



**Sentinel-2 Products  
Specification Document**

REF : S2-PDGS-TAS-DI-PSD  
 ISSUE : 14.5  
 DATE : 14/03/2018  
 PAGE : 251 / 510

<b>Geometric_Info/Tile_Geocoding</b>		
<b>Field Name</b>	<b>Description</b>	<b>Metatada Level</b>
HORIZONTAL_CS_NAME	Name of horizontal coordinate reference system.  Example for Tile 33VWG: WGS84 / UTM zone 33N	Brief
HORIZONTAL_CS_CODE	EPSG Code of horizontal coordinate reference system. The EPSG code contains the info of reference system (WGS84) and projection (UTM zone).  Example for Tile 33VWG: EPSG:32633	Brief
Size	Tile dimensions for each resolution band	Brief
Geoposition	XDIM and YDIM for each resolution band	Brief
<b>Geometric_Info/Tile_Angles</b>		
<b>Field Name</b>	<b>Description</b>	<b>Metatada Level</b>
Sun_Angles_Grid	Grid of sun angles (zenith and azimuth) and the correction which takes into account earth-sun distance variation and for each band sun equivalent irradiance	Standard
Mean_Sun_Angle	Mean value containing sun zenith and azimuth angle average for all bands and detectors	Standard
Mean_Incidence_Angle	List of mean values containing viewing incidence zenith and azimuth angle average for each band and for all detectors	Standard
Viewing_Incidence_Angles_Grids	Grid of incidence angles (zenith and azimuth) (per bands and detectors)	Standard

Table 58: Level-1C\_Tile\_Metadata\_File - Geometric\_Info Description



Quality Indicators Info:

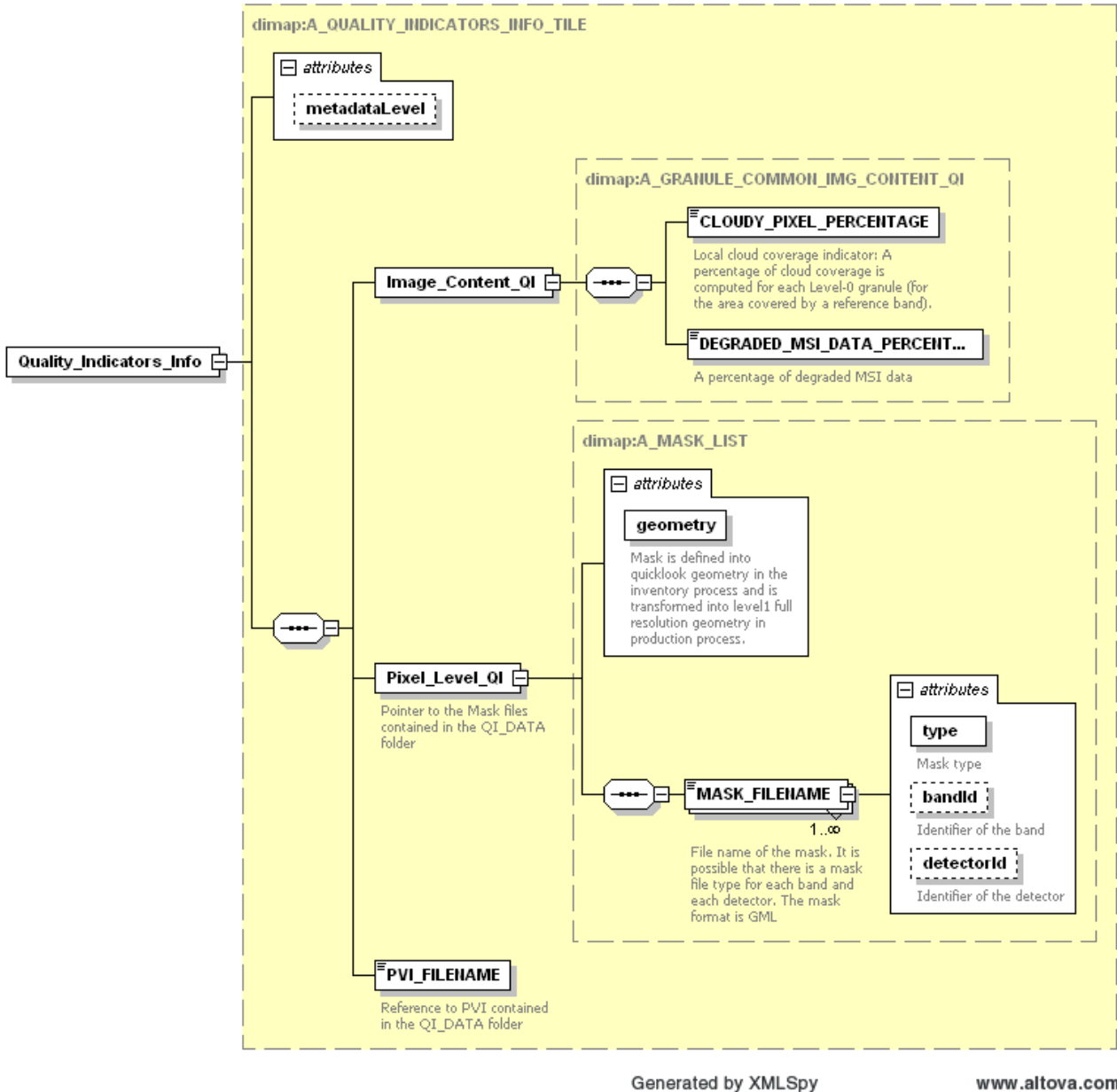

Figure 51: Level-1C\_Tile\_Metadata\_File – Quality\_Indicators\_Info Diagram

According to the content of the Table 16, the following table describes the Quality Indicators provided for a Level-1C Tile PDI.

Quality_Indicators_Info		
Field Name	Description	Metatada Level
CLOUDY_PIXEL_PERCENTAGE	Percentage of cloud coverage provided for each Tile.  The cloud percentage is computed taking into account (removing) the NO_DATA pixels eventually present in the Tile image.	Standard
DEGRADED_MSI_DATA_PERCENTAGE	Percentage of degraded MSI data provided for each Tile.	Standard
Quality_Indicators_Info/Pixel_Level_QI		
Field Name	Description	Metatada Level
MASK_FILENAME	Pointer to the mask files contained in the QI_DATA folder: <ul style="list-style-type: none"> <li>- Finer cloud mask files</li> <li>- Technical quality mask files</li> <li>- Detector footprint mask</li> <li>- Radiometric quality masks</li> </ul>	Standard
PVI_FILENAME	Reference to PVI contained in the QI_DATA folder	

Table 59: Level-1C\_Tile\_Metadata\_File – Quality\_Indicators\_Info Description

Note that, according to OLQC procedures consolidation, the results of all quality control checks performed by OLQC processor on Level-1C Tile, are included in the XML reports stored in the QI\_DATA folder (cf. section 3.4.1, Table 19).

### 3.11.3.2 IMG\_DATA

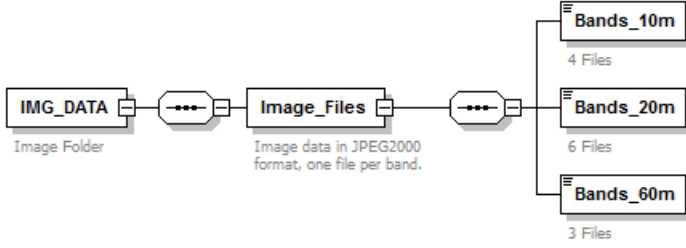
diagram	 <p align="center">Generated by XMLSpy <span style="float:right">www.altova.com</span></p>
children	<a href="#">Image_Files</a>
annotation	Folder containing image data (GML-JPEG2000), one file per spectral band (13 files).

### 3.11.3.3 QI\_DATA

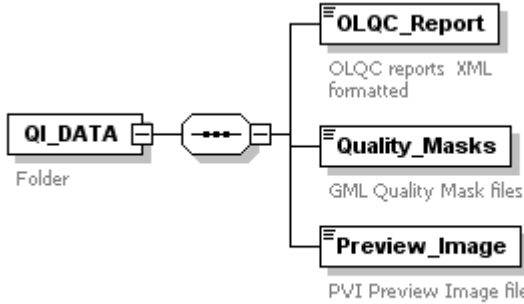
diagram	 <p align="center">Generated by XMLSpy <span style="float:right">www.altova.com</span></p>
children	<a href="#">OLQC_Report Quality_Masks</a>
annotation	<p>QI_DATA folder contains:</p> <ul style="list-style-type: none"> <li>• XML reports including the quality control checks performed by OLQC processor. The Annex C contains the description of OLQC reports</li> <li>• GML quality mask files; the masks files are listed in the Table 18</li> <li>• JPEG2000 Preview_Image file, always provided with a Level-1C Tile</li> </ul>

### 3.11.3.4 AUX\_DATA

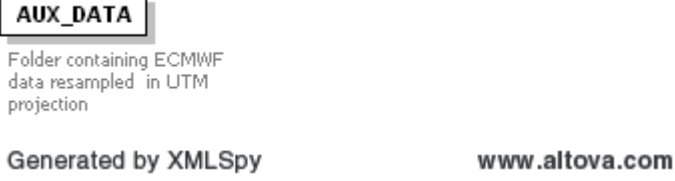
diagram	
children	-
annotation	<p>The raw ECMWF global forecast dataset are resampled and provided as part of the Level-1C Tile PDI. These data are distributed in grid information tiles with the same dimensions as the Level-1C Tiles. Grid points are provided in latitude/longitude using WGS84 reference system.</p> <p>They are interpolated from original ECMWF data to match L1C Tiles both temporally (linear) and geometrically (bilinear with a Ground Sample Distance of 12.5km).</p> <p>Each Tile contains one single ECMWF data file in GRIB V1 format (cf. [GIRB])</p>

### 3.11.4 SAFE Manifest synoptic table

This chapter provides a detailed description of the content of the SAFE Manifest for the Level-1C Granule PDI level.

The SAFE Manifest file is compliant to the SAFE specification (cf. [SAFE-SPEC]) and is composed (cf. section 3.4.4 by three main sections (Metadata, Information Package Map and Data Objects).

Part of the information contained in the Metadata section is extracted from the XML metadata file and is therefore duplicated in the SAFE Manifest and in the XML metadata file.

With reference to the three mentioned sections the chapter provides, as a guideline to the generation process of the SAFE Manifest file, the following elements:

- Table 31 describing the content and structure of the Information Package Map section; same consideration apply as in section 3.5.9;
- for the Metadata Section, a table that lists the fields (tags) composing the section, providing, for each field:
  - the field name in the SAFE Manifest file (column “SAFE Manifest”, divided into column “Metadata name”, containing the name of the Metadata section of the manifest to which the field belongs, and “Name of tag or attribute” containing the actual tag name or attribute name (for sake of clarity, attributes are written in bold characters))
  - the name of the corresponding tag (if available, else N.A.) of the XML Metadata File and of its XSD Schema (column “From S2\_PDI\_Level-1C\_Tile\_Metadata.xsd”);
  - a brief textual description of the field;
  - the data type of the field (e.g. string, string enum, integer, double, xs:dateTime etc.);

- the occurrence of the field (min/max occurrence e.g. 0..1); a minimum occurrence of 1 means that the field is mandatory;
  - the allowed range of values of the field.
- Table 33 describing the content and structure of the Data Objects section; consider that this section contains a reference to each file (Data files and Metadata files) composing the Level-1C Granule PDI (with the exception of the Manifest file itself); this includes:
    - the XML Granule Metadata file;
    - the XML Inventory\_Metadata file;
    - a set of image files in JPEG2000 format (one file per spectral band, up to a total of 13 files);
    - a set of Quality Indicator Data Files, including a OLQC Report file and one or more pixel-level Quality Mask files.

An example of Manifest file for the Level-1C Tile PDI, containing realistic, though indicative values, is provided as annexed zip file to this document (S2-PDGS-TAS-DI-PSD-V14\_SAFE.zip).



SAFE Manifest		From <i>S2_PDI_Level-1C_Tile_Metadata.xsd</i>	Description	Data Type	Occurrence	Allowed range of values
Metadata name	Name of tag or attribute (in bold)	Tag name				
platform						
	nssdcIdentifier	N.A.	Unique identifier of the platform, defined by the World Data center for Satellite Information (WDC-SI)		1	WDC is discontinued; this tag is set to a default value 0000-0000
	familyName	General_Info->TILE_ID (substring <Mission ID>, cf. section 3.11.1)	The mission name of the platform		0..1	Sentinel
	number	General_Info->TILE_ID (substring <Mission ID>, cf. section 3.11.1)	Sequence identifier of the platform among the mission	string enum	0..1	2A, 2B, 2C
	instrument->familyName	N.A.	The instrument name used for acquiring the product data	string enum	0..1	Multi-Spectral Instrument
	instrument-> <b>abbreviation</b>	N.A.	Abbreviation of the instrument name	string enum	0..1	MSI
	instrument->mode	N.A.	The mode of the instrument	string enum	0..1	Nominal_Observation Dark_Signal_Calibration Extended_Observation Absolute_Radiometry_Calibration Vicarious_Calibration Raw_Measurement Test_Mode
	Instrument->mode-> <b>identifier</b>	N.A.	The identifier of the instrument mode	string enum	1	INS-NOBS INS-EOBS

SAFE Manifest		From S2_PDI_Level-1C_Tile_Metadata.xsd	Description	Data Type	Occurrence	Allowed range of values
Metadata name	Name of tag or attribute (in bold)	Tag name				
						INS-DASC INS-ABSR INS-VIC INS-RAW INS-TST
processing			Textual description of the history of processings that lead to the current product and of all the relevant resources involved in the processing (facilities, software, applicable documents etc)		1	
	<b>name</b>	N.A.	Name of the Archiving process	string	0..1	Archiving of PDI Level-1C Tile Product
	<b>start</b>	General_Info->Archiving_Info ->ARCHIVING_TIME	Archiving start date (UTC)	xs:dateTime	0..1	
	facility		Description of Origin Centre		0..*	
	facility-> <b>name</b>	N.A.	Extended name of Origin Centre	string	1	
	facility-> <b>organization</b>	N.A.	Organization to which the Origin center belongs	string	0..1	
	facility-> <b>site</b>	General_Info->Archiving_Info ->ARCHIVING_CENTRE	The starting point of the circulation data	string enum	0..1	SGS_ MPS_ MTL_ EPA_ UPA_ CDAM MPC_
	facility-> <b>country</b>	N.A.	Country where Origin Centre is located	string	0..1	

SAFE Manifest		From S2_PDI_Level-1C_Tile_Metadata.xsd	Description	Data Type	Occurrence	Allowed range of values
Metadata name	Name of tag or attribute (in bold)	Tag name				
	resource		Description of product being archived		0..*	
	resource-> <b>name</b>	N.A.	Name of the product being archived	string	1	
	resource-> <b>role</b>	N.A.	Role of the resource	string	1	PDI Level-1C Tile Product
	resource-> processing		Description of the L1B to L1C Processing		0..*	
	resource-> processing-> <b>name</b>		Name of the L1B to L1C Processing	string	0..1	Processing of Level-1B Granule product
	resource-> processing-> <b>start</b>	General_Info->TILE_ID (substring <Creation Date>, cf. section 3.11.1)	Processing start date (UTC)	xs:dateTime	0..1	
	resource-> processing-> facility	N.A.	Description of Processing Centre		0..*	
	resource-> processing-> facility-> <b>name</b>	N.A.	Extended name of Origin Centre	string	1	
	resource-> processing-> facility-> <b>organization</b>	N.A.	Organization to which the Origin center belongs	string	0..1	
	resource-> processing-> facility-> <b>site</b>	General_Info->TILE_ID (substring <Site Centre>, cf. section 3.11.1)	Acronym of the Processing center	string enum	0..1	SGS_ MPS_ MTL_ EPA_ MPC_ UPA_ XXXX EDRS zzzL (zzz = first three)

SAFE Manifest		From S2_PDI_Level-1C_Tile_Metadata.xsd	Description	Data Type	Occurrence	Allowed range of values
Metadata name	Name of tag or attribute (in bold)	Tag name				
						characters of the LGS location)
	resource-> processing-> facility-> <b>country</b>	N.A.	Country where Origin Centre is located	string	0..1	
	resource-> processing-> facility-> software	N.A.	Description of software component used for Processing		0..*	
	resource-> processing-> facility-> software-> <b>name</b>	N.A.	Name of the software component	string	1	
	resource-> processing-> facility-> software-> <b>version</b>	N.A.	Version of the software component	string	0..1	
acquisitionPeriod					1	
	startTime	General_Info->TILE_ID (substring <Sensing Time>, cf. section 3.11.1)	Reference time of acquisition of the Granule	xs:dateTime	1	
measurementOrbitReference						
	orbitNumber	General_Info-> TILE_ID (substring <Abs Orbit>, cf. section 3.11.1)	Absolute orbit number			
	orbitNumber-> <b>type</b>		Absolute orbit number type (possible values "start" or "stop"). Set to fixed value "start" since the absolute orbit number refers to the first line of the Tile			
measurementFrameSet						

SAFE Manifest		From S2_PDI_Level-1C_Tile_Metadata.xsd	Description	Data Type	Occurrence	Allowed range of values
Metadata name	Name of tag or attribute (in bold)	Tag name				
	cloudVoteNotationSystem				0..1	
	cloudVoteNotationSystem-> <b>floor</b>	N.A.	Minimum value of cloud coverage index (Fixed value = 0.0)	double	0..1	0.0
	cloudVoteNotationSystem-> <b>ceil</b>	N.A.	Maximum value of cloud coverage index (Fixed value = 100.0)	double	0..1	100.0
	frame	N.A.	The "frame" concept is used in SAFE to convey the cloud coverage information by subdividing the region of interest of the data into "frames" according to a World Reference System. In the case of Sentinel-2 L1C Products, a similar concept can be used, by associating one single "frame" to the area covered by the Granule		0..1	
	frame->number	N.A.	Number of the band	integer	0..1	1
	frame->Tile	N.A.			1	One Tile for the single frame
	frame->Tile-> <b>row</b>	N.A.	The column index of the frame Tile. This index is numbered starting from 1.	integer	1	1 (there is only one Tile for the single frame)
	frame->Tile-> <b>column</b>	N.A.	The row index of the frame Tile. This index is numbered starting from 1.	integer	1	1 (there is only one Tile for the single frame)
	frame->Tile->cloudVote	Quality_Indicators_Info-> Image_Content_QI -> CLOUDY_PIXEL_PERCENTAGE	Numeric notation qualifying the cloud coverage of the frame Tile	double	0..1	0 to 100

SAFE Manifest		From <i>S2_PDI_Level-1C_Tile_Metadata.xsd</i>	Description	Data Type	Occurrence	Allowed range of values
Metadata name	Name of tag or attribute (in bold)	Tag name				
metadataComponents		N.A	A reference to all Metadata files included in the product (e.g. the XML Metadata file, the XML Inventory Metadata file)		2..11	
metadataComponentSchemas		N.A	A reference to the Schemas used to validate the Metadata files included in the product (e.g. the XML Metadata file Schema)		0..2	

Table 60 Content of Metadata Section for PDI Level-1C Tile SAFE Manifest

### 3.12 Level-1C Datastrip PDI definition

Level-1C Datastrip PDI is defined as a **tar** file containing the following structure:

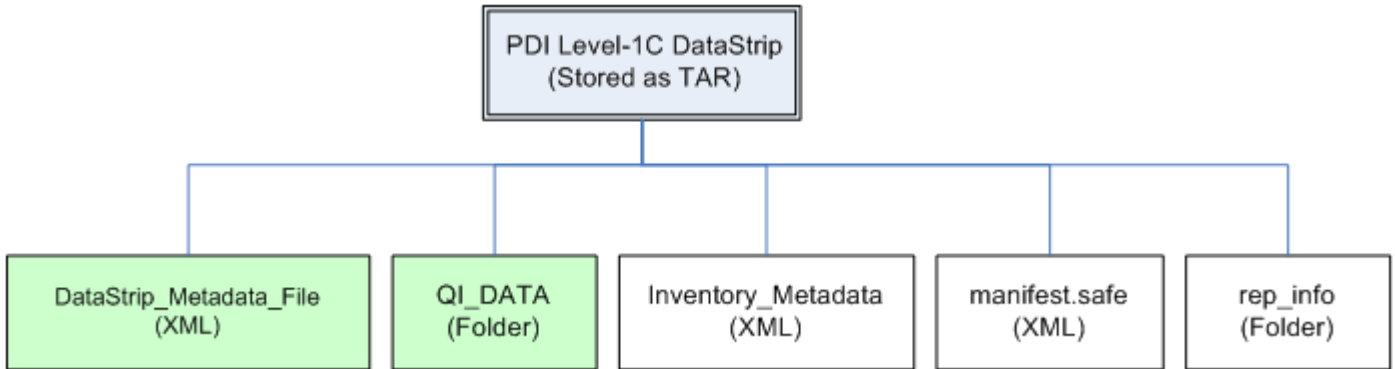

Figure 52: PDI Level-1C Datastrip Structure

The PDI Level-1C Datastrip consists of:

1. **Datastrip\_Metadata\_File**: XML metadata file containing the requested level of information and referring all the product elements composing the Datastrip,
2. **QI\_DATA**: folder containing XML reports including Quality control checks information,
3. **Inventory\_Metadata.xml**: file containing the metadata needed to inventory the PDI.
4. **manifest.safe**: XML SAFE Manifest file (mandatory, cf. section 3.5.4),
5. **rep\_info**: folder containing the available XSD schemas that validate the PDI components (recommended by [SAFE-SPEC], cf. section 3.5.4).

#### 3.12.1 PDI\_ID definition

Datastrip PDI\_ID (Datastrip ID) is defined in the section 3.5.2. The File\_Type is specified in the section 3.2, Table 5.

Level-1C Datastrip Template Name (Datastrip ID):

*S2A\_OPER\_MSI\_L1C\_DS\_SGS\_20141104T134012\_S20141104T134012\_N01.01.tar*

Note that the PDI ID.tar is the physical name of the Datastrip PDI after the tar compression.

### 3.12.2 Level-1C Datastrip Physical Format

The PDI ID defined above represents the “Datastrip directory” name. Inside the Datastrip directory, there are the Datastrip components as in the Figure 52:

Inside that directory, the naming convention used to identify each real files follows the same convention used to define the Datastrip ID but without the Processing Baseline sub-string.

- **Datastrip\_Metadata\_File (XML file):**

Datastrip\_Metadata\_File template name:

*S2A\_OPER\_MTD\_L1C\_DS\_SGS\_\_20141104T134012\_S20141104T134012.xml*

The XSD schema which regulates the metadata file is *S2\_PDI\_Level-1C\_Datastrip\_Metadata.xsd* included in the *S2-PDGS-TAS-DI-PSD-V14\_Schemas.zip* file annexed to the document.

- **QI\_DATA (folder):**

QI\_DATA folder contains XML reports *OLQC\_Report.xml* generated by On-Line Quality Control processor, including Quality Control Checks results. The *OLQC\_Report.xsd* schema and the reports naming convention are in the Annex C of the document.

- **Inventory\_Metadata (XML file):**

XML Inventory metadata file with fixed name *Inventory\_Metadata.xml*

- **manifest.safe (XML file):**







XML file with fixed name *manifest.safe*

- **rep\_info (folder):**

Folder containing the following XSD schemas:

1. *S2\_PDI\_Level-1C\_Datastrip\_Metadata.xsd*
2. *Inventory\_Metadata.xsd*
3. *OLQC\_Report.xsd*

Level-1C Datastrip Physical Format template:

Level-1C Datastrip PDI_ID: <i>S2A_OPER_MSI_L1C_DS_SGS__20141104T134012_S20141104T134012_N01.01</i>	
	<i>Inventory_Metadata.xml</i>
	<i>S2A_OPER_MTD_L1C_DS_SGS__20141104T134012_S20141104T134012.xml</i>
	<i>manifest.safe</i>
	QI_DATA
	<i>S2A_OPER_MSI_L1C_DS_SGS__20141104T134012_S20141104T134012_GEOMETRIC_QUALITY_report.xml</i>
	rep_info



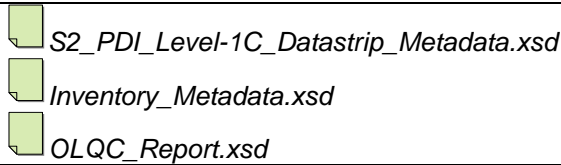
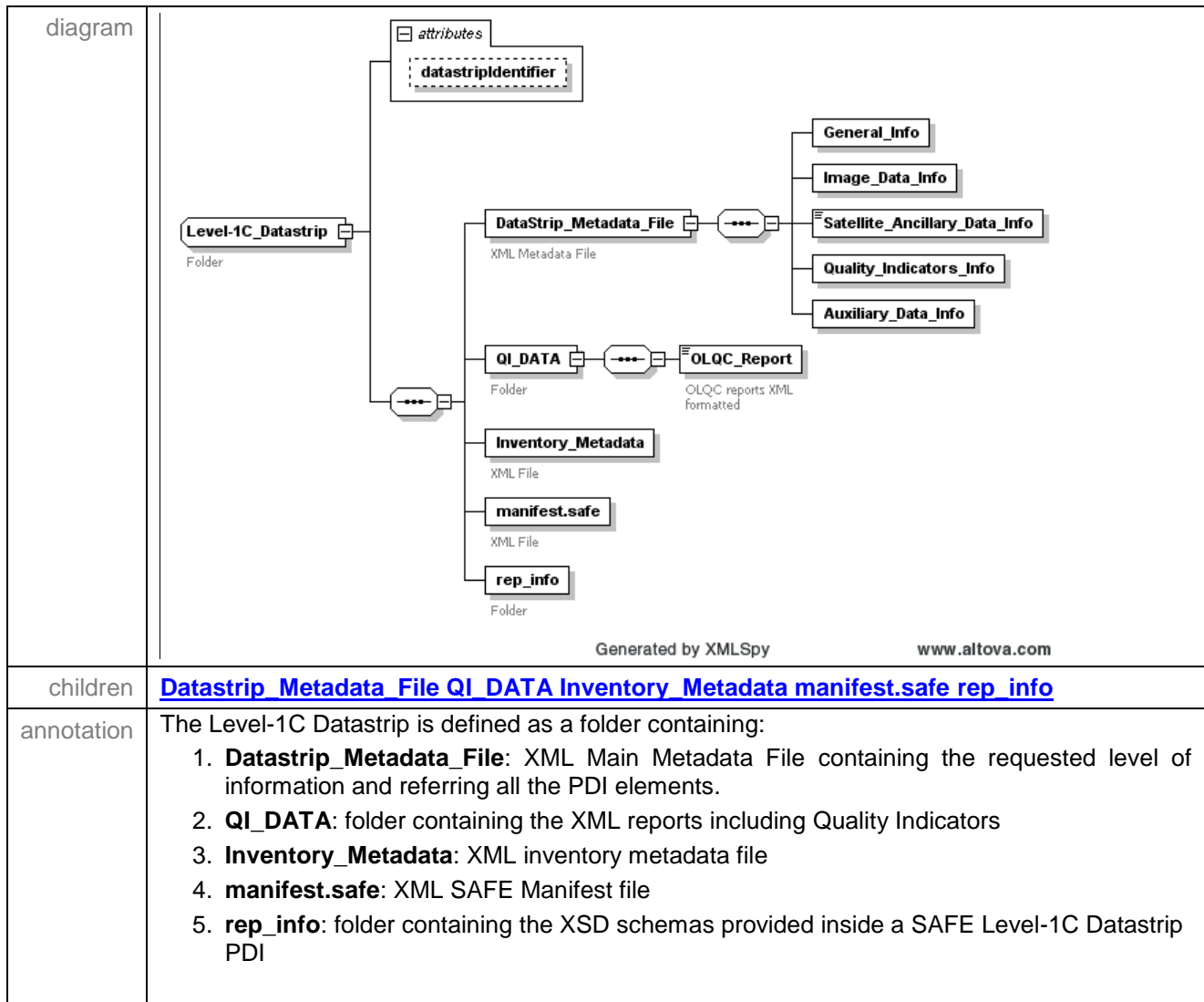

Figure 53: PDI Level-1C Datastrip Physical Format

### 3.12.3 Level-1C Datastrip PDI Structure

The *S2\_PDI\_Level-1C\_Datastrip\_Structure.xsd* schema annexed to the document and shown in the following diagram, represents the organization of a Level-1C Datastrip PDI on disk. This schema is provided for information only as It is actually not expected to be used for the validation of a XML file. The diagram reflects exactly the structure shown in the Figure 52.



Note that the Inventory\_Metadata.xml, manifest.safe and rep\_info are removed when the PDI is included in the User Product.

### 3.12.3.1 Datastrip\_Metadata\_File Schema

Level-1C Datastrip\_Metadata\_File is the XML metadata file provided inside each Level-1C Datastrip. The schema used to validate it is the *S2\_PDI\_Level-1C\_Datastrip\_Metadata.xsd* annexed to this document. A detailed description of the schema is given here but for specific details regarding each metadata (e.g. type, default value, fixed value, enumerations, occurrences, etc...) refers to the XSD file.

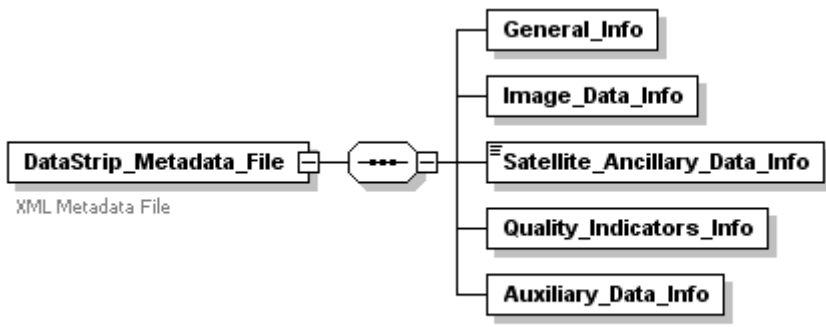
diagram	 <p align="center">Generated by XMLSpy <span style="float:right">www.altova.com</span></p>
children	<a href="#">General_Info</a> <a href="#">Image_Data_Info</a> <a href="#">Satellite_Ancillary_Data_Info</a> <a href="#">Quality_Indicators_Info</a> <a href="#">Auxiliary_Data_Info</a>
annotation	<p>The structure of the Datastrip_Matadata_File is common to all processing level (cfr. § 3.5.1)  The Datastrip_Metadata_File is an XML file containing all the metadata describing the whole product data item.</p> <ol style="list-style-type: none"> <li><b>General_Info:</b> This group of metadata provide general information characterizing the source Datastrip acquisition.</li> <li><b>Image_Data_Info:</b> Image data information from MSI telemetry.</li> <li><b>Satellite_Ancillary_Data_Info:</b> Ancillary data information from Satellite Ancillary Telemetry.</li> <li><b>Quality_Indicators_Info:</b> Results of all quality checks performed at Datastrip level.</li> <li><b>Auxiliary_Data_Info:</b> Auxiliary data information.</li> </ol>

The following tables and figures give a complete overview of the Level-1C Datastrip\_Metadata\_File schema according the description provided in the section 3.5.1.

#### General\_Info:

The General\_Info provided through the Level-1C DataSrip\_Metadata\_File are the same described in the Figure 20 and Table 3-32.

#### Image\_Data\_Info:

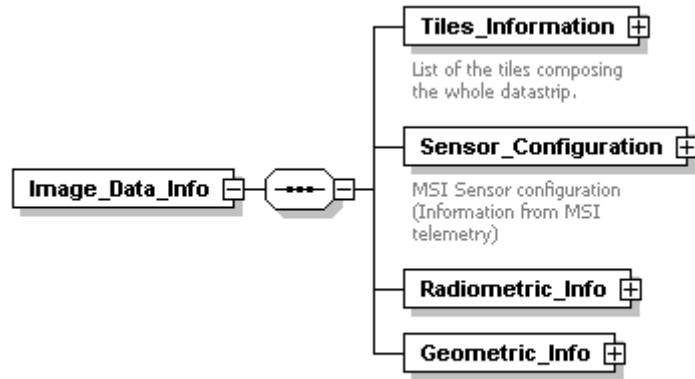

Generated by XMLSpy

www.altova.com

Figure 54 : Level-1C Datastrip – Image\_Data\_Info Diagram



**Sentinel-2 Products  
Specification Document**

REF : S2-PDGS-TAS-DI-PSD  
 ISSUE : 14.5  
 DATE : 14/03/2018  
 PAGE : 268 / 510

<b>Image_Data_Info/Tiles_Information</b>		
<b>Field Name</b>	<b>Description</b>	<b>Metatada Level</b>
Tile_List	List of the tiles composing the whole Datastrip. Each Tile is univocally identified through a unique Tile identifier (PDI_ID, § 3.11.1).	Standard
<b>Image_Data_Info/Sensor_Configuration (inherited from L1B)</b>		
<b>Field Name</b>	<b>Description</b>	<b>Metatada Level</b>
See Table 53	MSI Sensor configuration (Information from MSI telemetry)	Expertise
<b>Image_Data_Info/Radiometric_Info</b>		
<b>Field Name</b>	<b>Description</b>	<b>Metatada Level</b>
SWIR_REARRANGEMENT_PROC	SWIR pixels re-arrangement (only for level 1A production but SWIR rearrangement information shall be preserved in L1B and L1C): A 'true' value indicates that data extraction and SWIR pixels re-arrangement have been processed.	Standard
SATURATED_PIXELS_PROC	Management of saturated pixels. A 'true' value indicates that saturated pixels has been processed.	Standard
Spectral_Information_List/Spectral_Informatio/RESOLUTION	(OPTIONAL FIELDS)  Spectral filter information provided by the GIPP ABSOLUTE_CALIBRATION  Spatial resolution	Standard
Spectral_Information_List/Spectral_Informatio/Wavelength/MIN	Minimum wavelenght	Standard
Spectral_Information_List/Spectral_Informatio/Wavelength/MAX	Maximum wavelenght	Standard
Spectral_Information_List/Spectral_Informatio/Wavelength/CENTRAL	Central wavelenght	Standard
Spectral_Information_List/Spectral_Informatio/Spectral_Response/STEP	Step of spectral response	Standard
Spectral_Information_List/Spectral_Informatio/Spectral_Response/VALUES	List of measures	Standard





**Sentinel-2 Products  
Specification Document**

REF : S2-PDGS-TAS-DI-PSD  
 ISSUE : 14.5  
 DATE : 14/03/2018  
 PAGE : 269 / 510

Image_Display_Order/RED_CHANNEL	Relation between product image channels and on board spectral bands (Band index).	Standard
Image_Display_Order/GREEN_CHANNEL	Relation between product image channels and on board spectral bands (Band index).	Standard
Image_Display_Order/BLUE_CHANNEL	Relation between product image channels and on board spectral bands (Band index).	Standard
QUANTIFICATION_VALUE	Reflectance quantification value (in order to convert digit count into reflectance)	Standard
Reflectance_Conversion/U	Correction to take into account the Sun-Earth distance variation (this correction is computed using the acquisition date)	Standard
Reflectance_Conversion/Solar_Irradiance_List/SOLAR_IRRADIANCE	Reflectance parameters defined for each band	Standard
<b>Image_Data_Info/Geometric_Info</b>		
<b>Field Name</b>	<b>Description</b>	<b>Metatada Level</b>
RGM	Flag to identify if the Refined Geometric Model file is computed or obtained from a existing RGM file (reused)	Standard
Image_Refining	Refining results. Should exist only if REFINING_TYPE= REFINING or REFINING_REGISTRATION	Standard
VNIR_SWIR_Registration	Registration results. Should exist only if REFINING_TYPE= REGISTRATION or REFINING_REGISTRATION	Standard
Refined_Corrections_List	Description of the refined corrections. If the refining has been processed by Datastrip then, there are the refined corrections for each Datastrip. These data are created by Geo_S2	Standard
<b>Image_Data_Info/Product_Compression (OPTIONAL)</b>		
<b>Field Name</b>	<b>Description</b>	<b>Metatada Level</b>
COMPRESSION	Product Compression.  The compression may be: - None. - LOSSLESS: Lossless compression, use	Standard





**Sentinel-2 Products  
Specification Document**

REF : S2-PDGS-TAS-DI-PSD  
ISSUE : 14.5  
DATE : 14/03/2018  
PAGE : 270 / 510

	reversible JPEG2000 compression. - LOSSY: Lossy compression, use compression that ensures that JPEG2000 compression has a negligible effect on image quality.	
--	--	--

Table 61: Level-1C Datastrip – Image\_Data\_Info Description



Satellite Ancillary Data info:

The Satellite\_Ancillary\_Data\_Info are the same provided for a L0 Datastrip (cfr. Figure 22 and Table 36).

Quality Indicators Info:

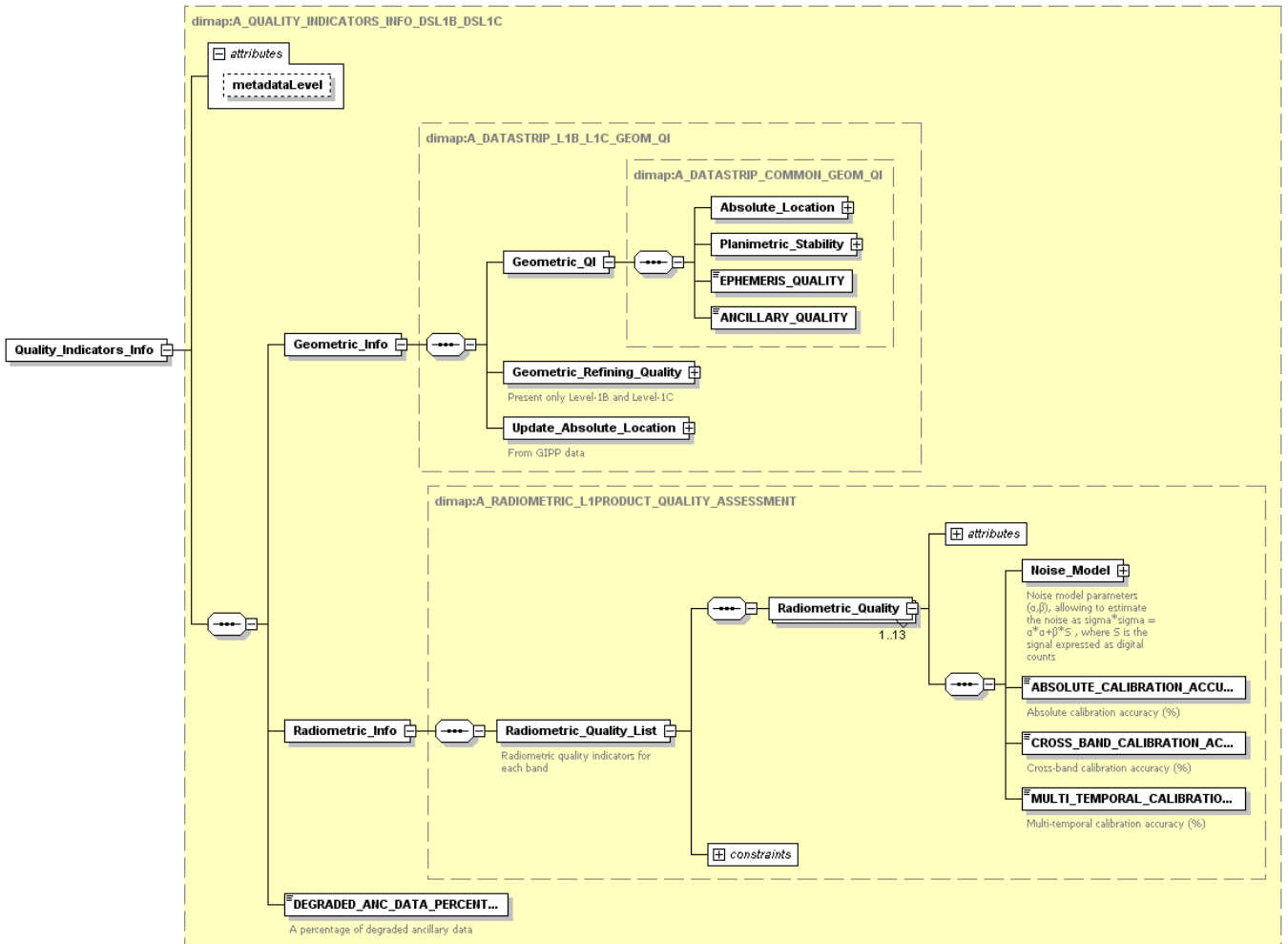

Generated by XMLSpy

www.altova.com

Figure 55: Level-1C Datastrip – Quality\_Indicators\_Info Diagram



**Sentinel-2 Products  
Specification Document**

REF : S2-PDGS-TAS-DI-PSD  
ISSUE : 14.5  
DATE : 14/03/2018  
PAGE : 272 / 510

Quality_Indicators_Info/Geometric_Info		
Field Name	Description	Metadata Level
Geometric_QI/Absolute_Location	Absolute location performance for the Datastrip given from a GIPP table, depending on the health status of the GPS and AOCS sensors (gyros and startrackers) provided in the Satellite Ancillary Data.	Brief
Geometric_QI/Planimetric_Stability	A planimetric stability performance for the Datastrip given from a GIPP table, depending on the health status of the GPS and AOCS sensors (gyros and startrackers) provided in the Satellite Ancillary Data.	Brief
Geometric_QI/EPHEMERIS_QUALITY	Ephemeris data quality retrieved from GPS Dilution of precision (DOP) information.	Brief
Geometric_QI/ANCILLARY_QUALITY	Ancillary data quality retrieved from GPS Dilution of precision (DOP) information.	Brief
Geometric_Refining_Quality	Available by Datastrip and only if geometric refining is applied. Include Multi_Spectral_Registration performance (3 values for 10, 20 and 60m bands (from GIPP data).	Brief
Update_Absolute_Location	From GIPP data	Brief
Quality_Indicators_Info/Radiometric_Info		
Field Name	Description	Metadata Level
Noise_Model	Alpha and Beta parameters providing the instrument noise as a function of the radiometric count X for Level-1B : $Noise = \text{square root}(\text{Alpha}_X + \text{Beta}_X * X)$	Brief
ABSOLUTE_CALIBRATION_ACCURACY	Absolute calibration accuracy provided as a percentage of accuracy	Brief
CROSS_BAND_CALIBRATION_ACCURACY	Cross-band calibration accuracy provided as a percentage of accuracy	Brief
MULTI_TEMPORAL_CALIBRATION_ACCURACY	Multi-temporal calibration accuracy provided as a percentage of accuracy	Brief
DEGRADED_ANC_DATA_PERCENTAGE	Percentage of degraded ancillary data	Brief

Table 62: Level-1C Datastrip – Quality\_Indicators\_Info Description





## Auxiliary Data Info:

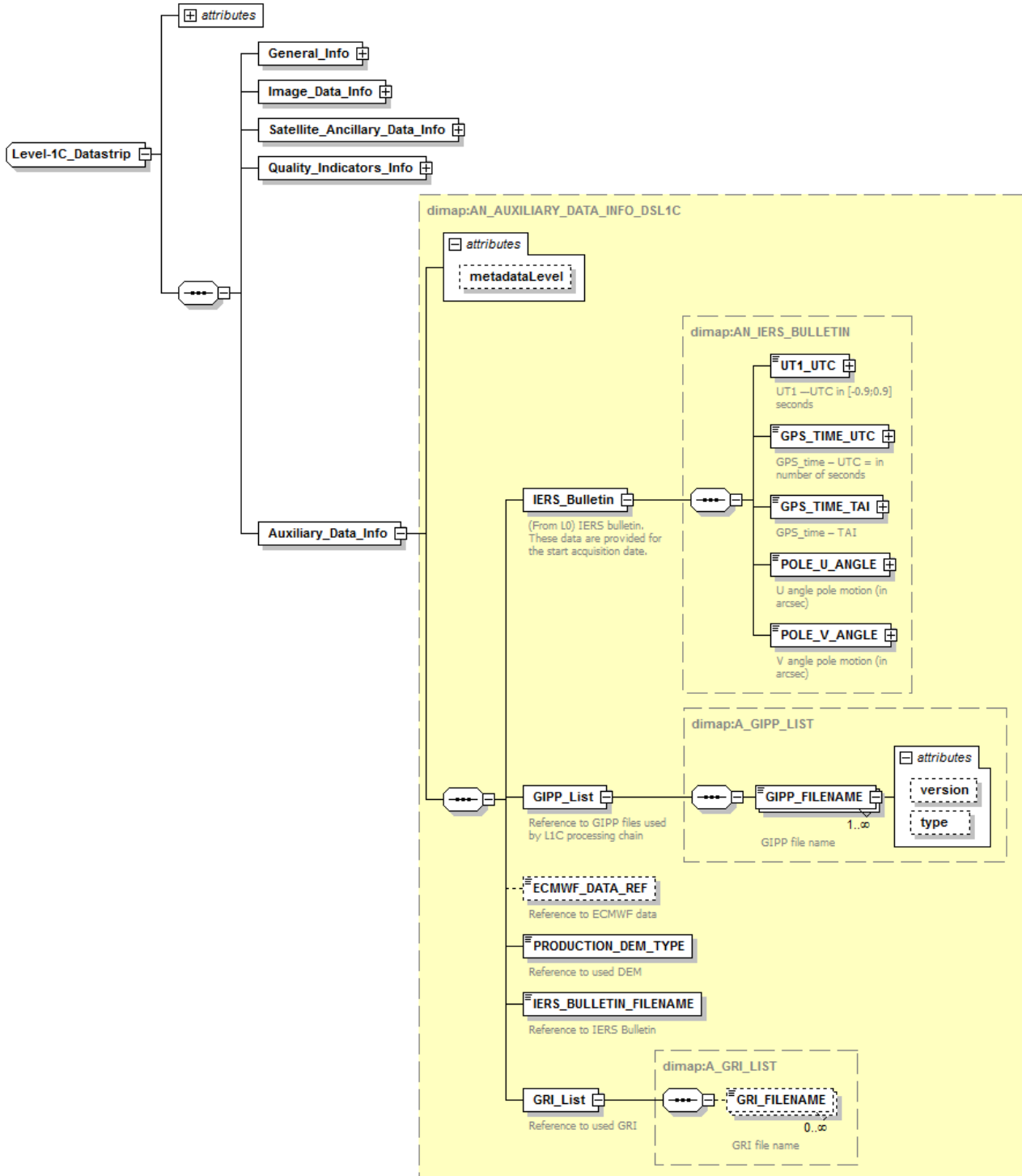

Generated by XMLSpy

www.altova.com

Figure 56 : Level-1C Datastrip – Auxiliary\_Data\_Info Diagram



## Sentinel-2 Products Specification Document

REF : S2-PDGS-TAS-DI-PSD  
ISSUE : 14.5  
DATE : 14/03/2018  
PAGE : 275 / 510

Auxiliary_Data_Info/IERS_Bulletin (from Level-1B)		
Field Name	Description	Metatada Level
UT1.UTC	UT1 --UTC in [-0.9;0.9] seconds	Standard
GPS_TIME.UTC	GPS_time – UTC = in number of seconds	Standard
GPS_TIME.TAI	GPS_time – TAI	Standard
POLE_U.ANGLE	U angle pole motion (in arcsec)	Standard
POLE_V.ANGLE	V angle pole motion (in arcsec)	Standard
Auxiliary_Data_Info (aux data used by the processing)		
Field Name	Description	Metatada Level
GIPP_List/GIPP_FILENAME	Reference to the GIPP files used by the L1C processing.	Standard
ECMWF_DATA_REF	Reference to raw ECMWF data (PDI)	Standard
PRODUCTION_DEM_TYPE	Inerited from L1B production	Standard
IERS_BULLETIN_FILENAME	Inerited from L1B production	Standard
GRI_List/GRI_FILENAME	Inerited from L1B production	Standard

Table 63: Level-1C Datastrip – Auxiliary\_Data\_Info Description

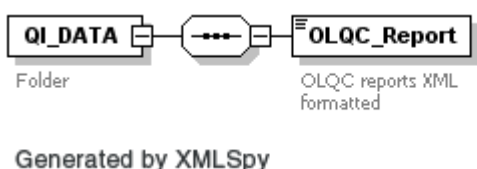

### 3.12.3.2 QI\_DATA

diagram	
children	<a href="#">OLQC_Report</a>
annotation	<p>QI_DATA folder contains:</p> <ul style="list-style-type: none"> <li>- XML reports generated by On-Line Quality Control processor, including Quality Control Checks results. The Annex C contains the description of OLQC reports</li> </ul>

### 3.12.4 SAFE Manifest synoptic table

This chapter provides a detailed description of the content of the SAFE Manifest for the Level-1C Datastrip PDI level.

The SAFE Manifest file is compliant to the SAFE specification (cf. [SAFE-SPEC]) and is composed (cf. section 3.4.4) by three main sections (Metadata, Information Package Map and Data Objects).

Part of the information contained in the Metadata section is extracted from the XML metadata file and is therefore duplicated in the SAFE Manifest and in the XML metadata file.

With reference to the three mentioned sections the chapter provides, as a guideline to the generation process of the SAFE Manifest file, the following elements:

- Table 31 describing the content and structure of the Information Package Map section; same consideration apply as in section 3.5.9;
- for the Metadata Section, a table that lists the fields (tags) composing the section, providing, for each field:
  - the field name in the SAFE Manifest file (column “SAFE Manifest”, divided into column “Metadata name”, containing the name of the Metadata section of the manifest to which the field belongs, and “Name of tag or attribute” containing the actual tag name or attribute name (for sake of clarity, attributes are written in bold characters))
  - the name of the corresponding tag (if available, else N.A.) of the XML Metadata File and of its XSD Schema (column “From S2\_PDI\_Level-1C\_Datastrip\_Metadata.xsd”);
  - a brief textual description of the field;
  - the data type of the field (e.g. string, string enum, integer, double, xs:dateTime etc.);

- the occurrence of the field (min/max occurrence e.g. 0..1); a minimum occurrence of 1 means that the field is mandatory;
- the allowed range of values of the field.

In particular, the satellite ancillary data files (e.g. the SAD Raw Data file) and the auxiliary data files used for Level-1C processing (e.g. GIPP files, DEM, IERS Bulletin), are external to the product and are referenced in the Metadata of Manifest file Section (as “resources” in the “processing” section).

- Table 33 describing the content and structure of the Data Objects section; consider that this section contains a reference to each file (Data files and Metadata files) composing the Level-1C PDI (with the exception of the Manifest file itself); this includes:
  - the XML Metadata file;
  - the XML Inventory\_Metadata file;
  - a set of Quality Indicator Data Files, including a OLQC Report file (XML format) and five Preliminary Quick Look files (in JPEG2000 format).

An example of Manifest file for the Level-1C Datastrip PDI containing realistic, though indicative values, is provided as annexed zip file to this document (S2-PDGS-TAS-DI-PSD-V14\_SAFE.zip).

SAFE Manifest		From S2_PDI_Level-1C_Datastrip_Metadata.xsd	Description	Data Type	Occurrence	Allowed range of values
Metadata name	Name of tag or attribute (in bold)	Tag name				
platform						
	nssdcIdentifier	N.A.	Unique identifier of the platform, defined by the World Data center for Satellite Information (WDC-SI)		1	WDC is discontinued; this tag is set to a default value 0000-0000
	familyName	General_Info->Datatake_Info->SPACECRAFT_NAME	The mission name of the platform	string enum	0..1	Sentinel
	number	General_Info->Datatake_Info->SPACECRAFT_NAME	Sequence identifier of the platform among the mission	string enum	0..1	2A, 2B, 2C
	instrument->familyName	N.A.	The instrument name used for acquiring the product data	string enum	0..1	Multi-Spectral Instrument
	instrument->abbreviation	N.A.	Abbreviation of the instrument name	string enum	0..1	MSI
	instrument->mode	N.A.	The mode of the instrument	string enum	0..1	Nominal_Observation Dark_Signal_Calibration Extended_Observation Absolute_Radiometry_Calibration Vicarious_Calibration Raw_Measurement Test_Mode
	instrument->mode->identifier	General_Info->Datatake_Info->DATATAKE_TYPE	The identifier of the instrument mode	string enum	1	INS-NOBS INS-EOBS INS-DASC INS-ABSR INS-VIC INS-RAW

SAFE Manifest		From S2_PDI_Level-1C_Datastrip_Metadata.xsd	Description	Data Type	Occurrence	Allowed range of values
Metadata name	Name of tag or attribute (in bold)	Tag name				
						INS-TST
processing			Textual description of the history of processings that lead to the current product and of all the relevant resources involved in the processing (facilities, software, applicable documents etc)		1	
	<b>name</b>	N.A.	Name of the Archiving process	string	0..1	Archiving of PDI Level-1C Datastrip Product
	<b>start</b>	Level-1C_Datastrip_ID->General_Info->Archiving_Info->ARCHIVING_TIME	Archiving start date (UTC)	xs:dateTime	0..1	
	facility		Description of Origin Centre		0..*	
	facility-> <b>name</b>	N.A.	Extended name of Origin Centre	string	1	
	facility-> <b>organization</b>	N.A.	Organization to which the Origin center belongs	string	0..1	
	facility-> <b>site</b>	General_Info->Archiving_Info->ARCHIVING_CENTRE	The starting point of the circulation data	string enum	0..1	SGS_ MPS_ MTI_ EPA_ UPA_ CDAM_ MPC_
	facility-> <b>country</b>	N.A.	Country where Origin Centre is located	string	0..1	

SAFE Manifest		From S2_PDI_Level-1C_Datastrip_Metadata.xsd	Description	Data Type	Occurrence	Allowed range of values
Metadata name	Name of tag or attribute (in bold)	Tag name				
	resource		Description of product being archived		0..*	
	resource-> <b>name</b>	N.A.	Name of the product being archived	string	1	
	resource-> <b>role</b>	N.A.	Role of the resource	string	1	PDI Level-1C Datastrip Product
	resource-> processing		Description of the L1B to L1C Processing		0..*	
	resource-> processing-> <b>name</b>		Name of the L1B to L1C Processing	string	0..1	Processing of Level-1B Datastrip product
	resource-> processing-> <b>start</b>	General_Info->Processing_Info->PROCESSING_TIME	Processing start date (UTC)	xs:dateTime	0..1	
	resource-> processing-> facility	N.A.	Description of Processing Centre		0..*	
	resource-> processing-> facility-> <b>name</b>	N.A.	Extended name of Origin Centre	string	1	
	resource-> processing-> facility-> <b>organization</b>	N.A.	Organization to which the Origin center belongs	string	0..1	
	resource-> processing-> facility-> <b>site</b>	General_Info->Processing_Info->PROCESSING_CENTER	Acronym of the Processing center	string enum	0..1	SGS_ MPS_ MTI_ EPA_ MPC_ UPA_ XXXX EDRS zzzL (zzz = first three characters of the LGS location)





**Sentinel-2 Products  
Specification Document**

REF : S2-PDGS-TAS-DI-PSD  
 ISSUE : 14.5  
 DATE : 14/03/2018  
 PAGE : 281 / 510

SAFE Manifest		From S2_PDI_Level-1C_Datastrip_Metadata.xsd	Description	Data Type	Occurrence	Allowed range of values
Metadata name	Name of tag or attribute (in bold)	Tag name				
	resource-> processing-> facility-> <b>country</b>	N.A.	Country where Origin Centre is located	string	0..1	
	resource-> processing-> facility->software	N.A.	Description of software component used for Processing		0..*	
	resource-> processing-> facility->resource		List of auxiliary data files used by the processors to support radiometric and geometric correction (GIPP, DEM, GRI, IERS Bulletin etc.) and of SAD Raw Data file containing the satellite ancillary telemetry; these files are not provided with the product.		0..*	
	resource-> processing-> facility->resource-> <b>name</b>	Satellite_Ancillary_Data_Info->ANC_DATA_REF (reference to the folder containing the SAD Raw Data files) Auxiliary_Data_Info->IERS_BulletinN Auxiliary_Data_Info->GIPP_List->GIPP_FILENAME	Absolute path name of the auxiliary or ancillary file/folder	string	1	
	resource-> processing-> facility->resource-> <b>role</b>	N.A.	Role of the resource	string	1	Auxiliary data, Ancillary data
acquisitionPeriod					1	





**Sentinel-2 Products  
Specification Document**

REF : S2-PDGS-TAS-DI-PSD  
 ISSUE : 14.5  
 DATE : 14/03/2018  
 PAGE : 282 / 510

SAFE Manifest		From S2_PDI_Level-1C_Datastrip_Metadata.xsd	Description	Data Type	Occurrence	Allowed range of values
Metadata name	Name of tag or attribute (in bold)	Tag name				
	acquisitionPeriod ->startTime	Datastrip->L1C_Datastrip_PDI_ID (substring <Sensing Time>, cf. section 3.5.6)	Reference time of acquisition of the Granule (corresponding to sensing time of the first line of the PDI at Datastrip level, cf. section 3.5.6)	xs:dateTime	1	
measurementOrbitReference						
	orbitNumber	General_Info->Datatake_Info->DatatakeIdentifier (substring <AbsoluteOrbitNumber>)	Absolute orbit number		0..1	> 0
	orbitNumber->type	N.A.	Absolute orbit number type (possible values "start" or "stop"). Set to "start" since the absolute orbit number refers to the first line of the Datastrip		0..1	start
	orbitNumber->groundTrackDirection	General_Info->Datatake_Info->SENSING_ORBIT_DIRECTION	Direction of the ground track of the Sentinel-2 platform at the time corresponding to orbitNumber->type (start or stop)		0..1	ascending, descending
	relativeOrbitNumber	General_Info->Datatake_Info->SENSING_ORBIT_NUMBER	Relative orbit number (within the cycle)		0..1	1 to 143
	relativeOrbitNumber->type	N.A.	Relative orbit number type (possible values "start" or "stop"). Set to "start" since the absolute orbit number refers to the first line of the		0..1	start



SAFE Manifest		From <i>S2_PDI_Level-1C_Datastrip_Metadata.xsd</i>	Description	Data Type	Occurrence	Allowed range of values
Metadata name	Name of tag or attribute (in bold)	Tag name				
			Datastrip			
metadataComponents		N.A	A reference to all Metadata files included in the product (e.g. the XML Metadata file, the XML Inventory Metadata file)		2..4	
metadataComponentSchemas		N.A	A reference to the Schemas used to validate the Metadata files included in the product (e.g. the XML Metadata file Schema)		0..2	

Table 64 - Content of Metadata Section for PDI Level-1C Datastrip SAFE Manifest

### 3.13 Level-2A Tile PDI definition

Level-2A Tile PDI level is defined as a **tar** file with the following structure:

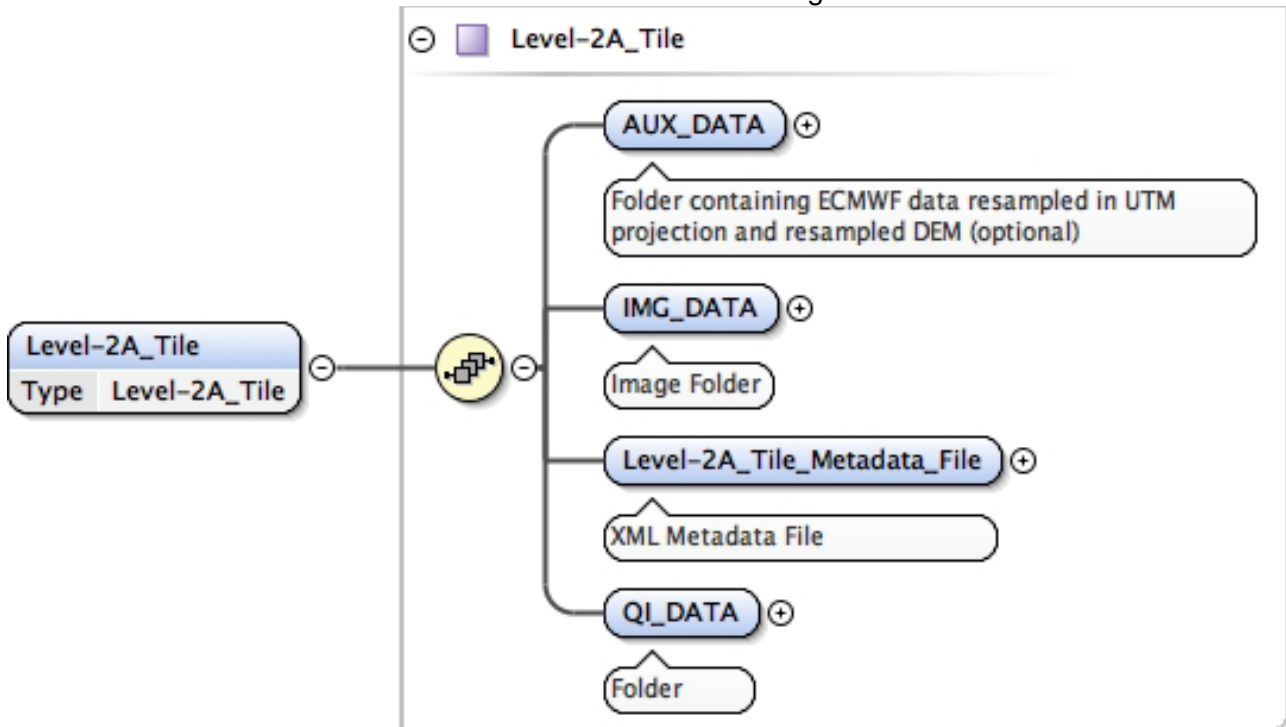

Figure 57: PDI Level-2A Tile Structure

The PDI Level-2A Tile consists of:

1. **Level-2A\_Tile\_Metadata\_File**: XML metadata file containing the requested level of information and referring all the product elements composing the Tile;
2. **IMG\_DATA**: folder containing image data files compressed using the JPEG2000 algorithm;
3. **QI\_DATA**: folder containing XML reports including quality checks, GML mask files and JP2 PVI file;
4. **AUX\_DATA**: folder containing ECMWF data resampled in UTM projection;
5. **Inventory\_Metadata.xml**: file containing the metadata needed to inventory the PDI (this is not an output of Sen2Cor);

#### 3.13.1 PDI\_ID definition

The PDI\_ID (Tile ID), used to identify a Level-2A Tile PDI, follows the description provided in the section 3.4.2. File\_Type is defined in the section 3.2, Table 5 using the File\_Type field "MSI\_L2A\_TL\_".

Level-2A Tile template name (Tile ID):

S2A\_OPER\_MSI\_L2A\_TL\_MTI\_20141104T134012\_A123456\_T15SWC\_N11.11



**Sentinel-2 Products  
Specification Document**

REF : S2-PDGS-TAS-DI-PSD  
ISSUE : 14.5  
DATE : 14/03/2018  
PAGE : 285 / 510

Note that the PDI\_ID.tar is the physical name of the Tile PDI after the tar compression.



### 3.13.2 Level-2A Tile PDI Structure

The *S2\_PDI\_Level-2A\_Tile\_Structure.xsd* schema annexed to the document and shown in the following diagrams, represents the organization of a Level-2A Tile PDI on disk. This schema is provided for information only as It is actually not expected to be used for the validation of a XML file.

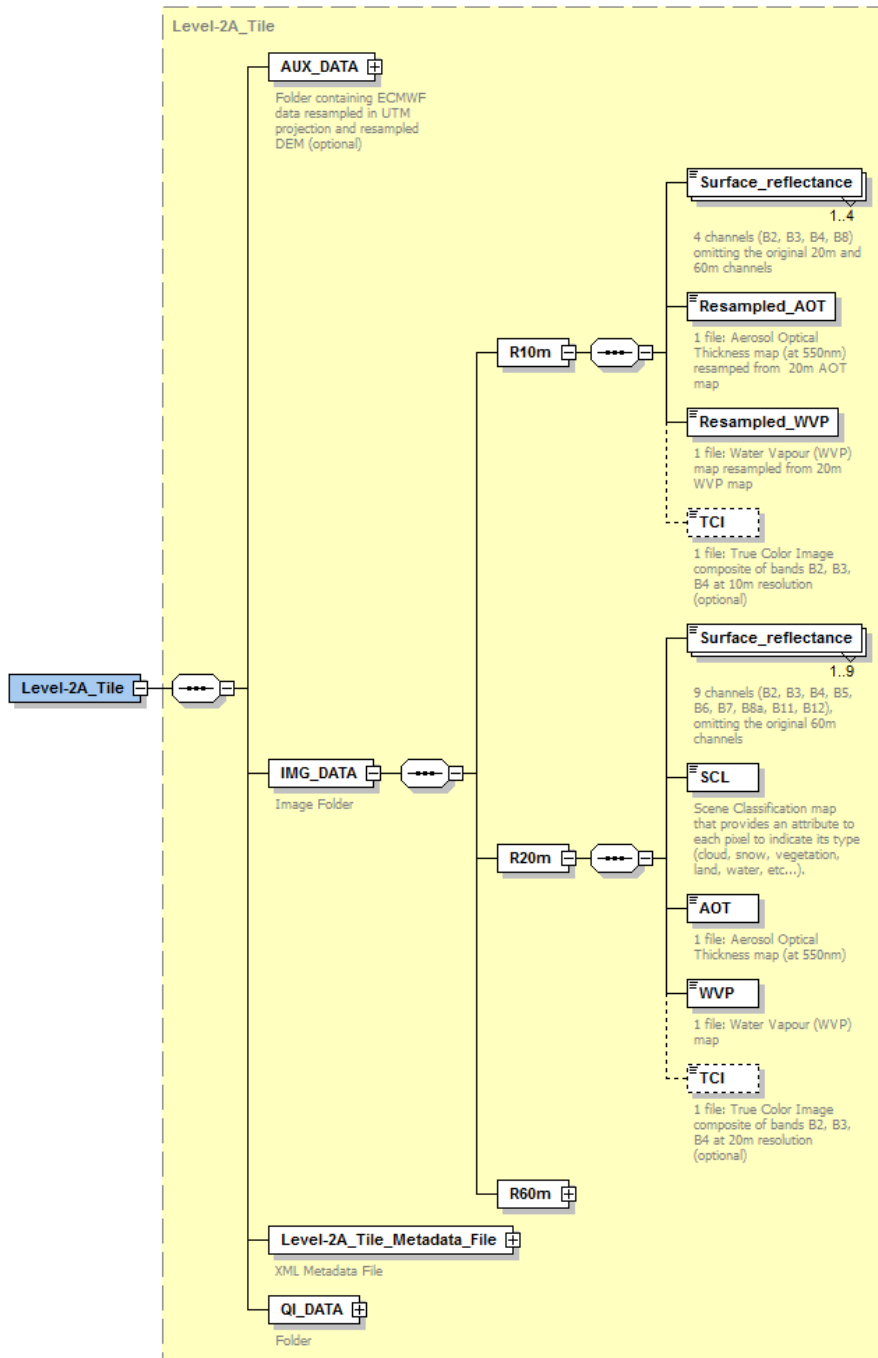

Figure 58: Level-2A Tile structure

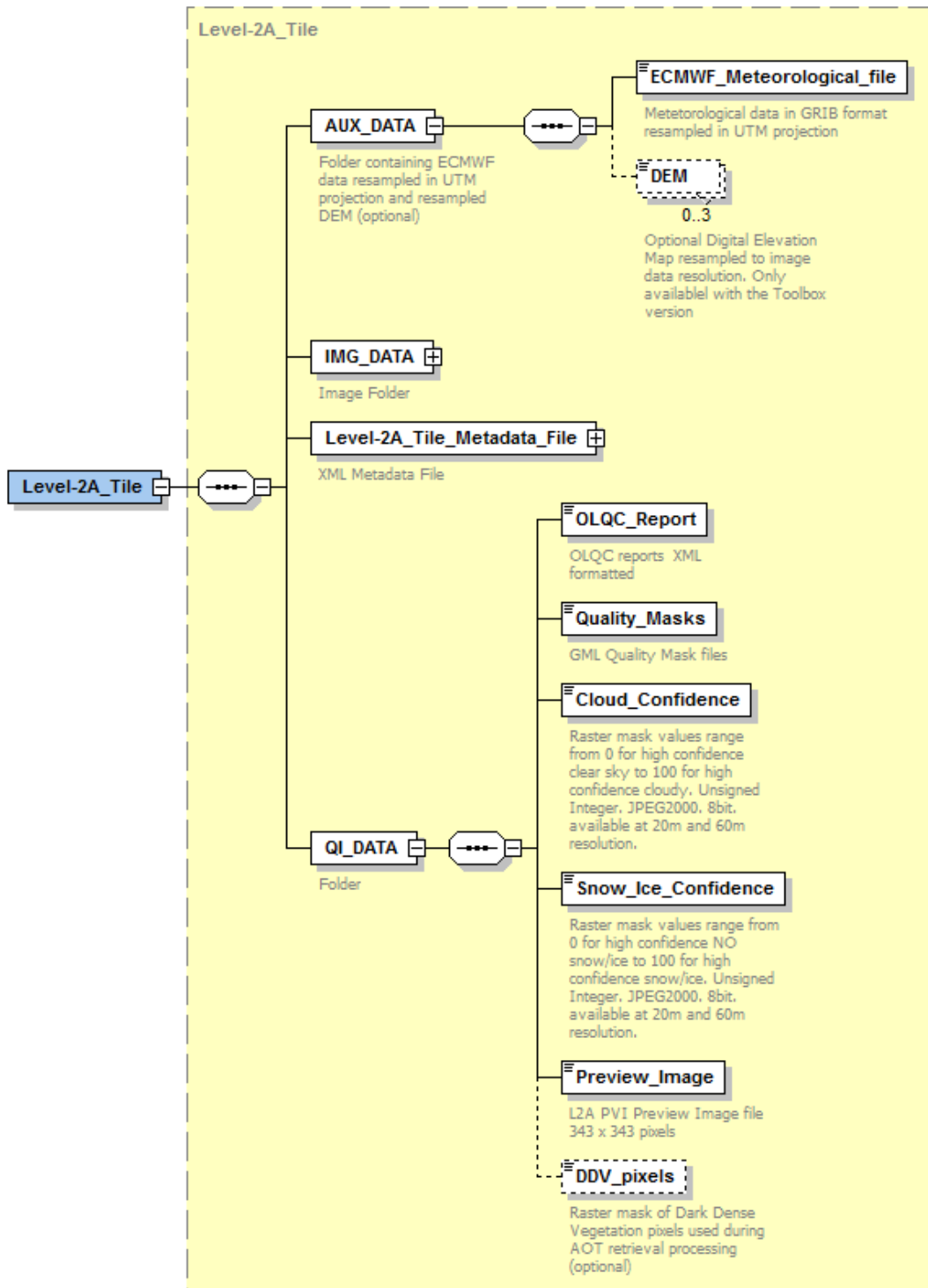
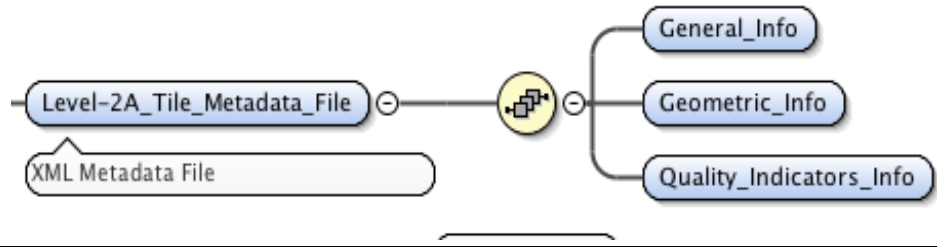

Figure 59: Level-2A Tile structure



### 3.13.2.1 Level-2A\_Tile\_Metadata\_File Schema

Level-2A\_Tile\_Metadata\_File is the XML metadata file provided inside each Level-2A Tile. The schema used to validate it is the *S2\_PDI\_Level-2A\_Tile\_Metadata.xsd* annexed to this document. A detailed description of the schema is given here but for specific details regarding each metadata (e.g. type, default value, fixed value, enumerations, occurrences, etc...) refers to the XSD file.

diagram	 <pre> classDiagram     class Level_2A_Tile_Metadata_File     class XML_Metadata_File     class General_Info     class Geometric_Info     class Quality_Indicators_Info     Level_2A_Tile_Metadata_File "1" -- "*" XML_Metadata_File     Level_2A_Tile_Metadata_File "1" -- "*" General_Info     Level_2A_Tile_Metadata_File "1" -- "*" Geometric_Info     Level_2A_Tile_Metadata_File "1" -- "*" Quality_Indicators_Info     </pre>
children	<a href="#">General Info</a> <a href="#">Geometric Info</a> <a href="#">Quality Indicators Info</a>
annotation	<p>The Level-2A_Tile_Metadata_File is an XML file containing:</p> <ol style="list-style-type: none"> <li>1. <b>General_Info</b>: to provide general Tile information.</li> <li>2. <b>Geometric_Info</b>: to provide information regarding the Tile geolocation.</li> <li>3. <b>Quality_Indicators_Info</b>: to provide information about image content quality indicators and quality control checks information.</li> </ol>

The following figures and tables give a complete overview of the Level-2A\_Tile\_Metadata\_File schema.

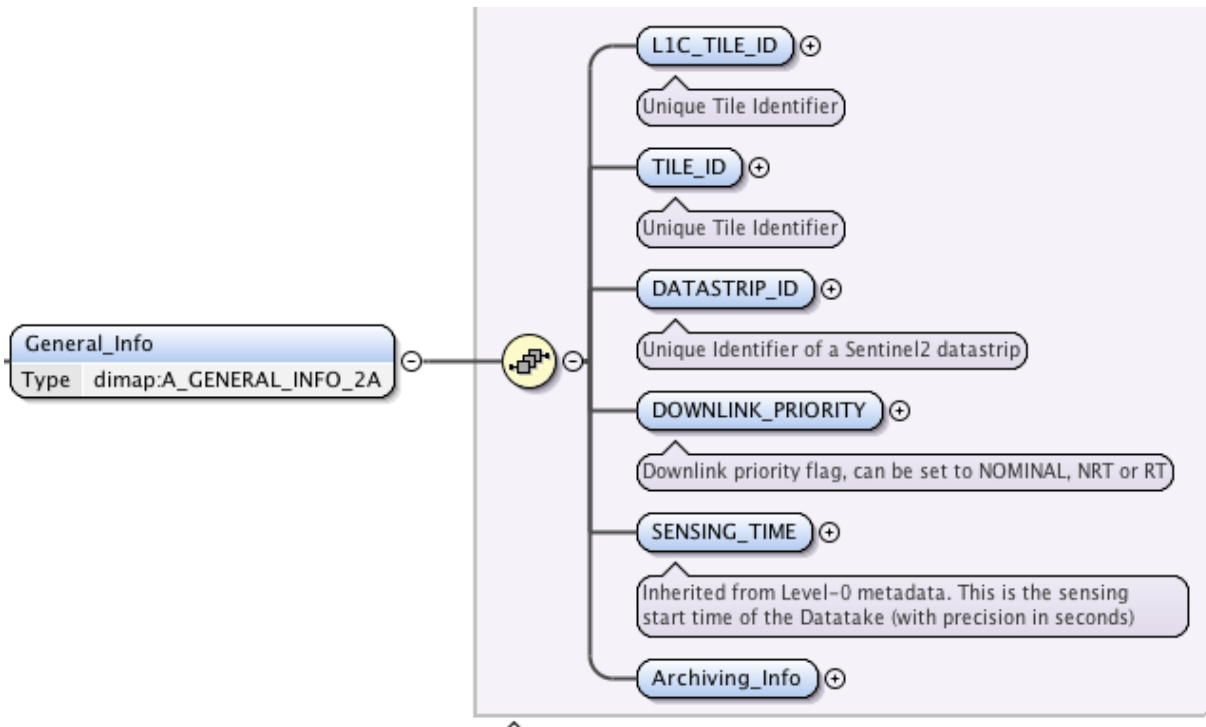

Figure 60: Level-2A\_Tile\_Metadata\_File - General\_Info Diagram

General_Info		
Field Name	Description	Metatada Level
L1C_TILE_ID	TILE identifier of the input L1C	
TILE_ID	L2A TILE identifier	Brief
DATASTRIP_ID	Unique identifier of the L2A Datastrip PDI linked to the L2A Tile PDI.	Standard
DOWNLINK_PRIORITY	Downlink priority flag. It can be set Nominal/NRT/RT.	Standard
SENSING_TIME	TILE Start Time. This value is currently set to the Datastrip Start Time	Standard
Archiving_Info/ARCHIVING_CENTRE	The starting point of the circulation data. The allowed values are: <ul style="list-style-type: none"> <li>• SGS_</li> <li>• MPS_</li> <li>• MTI_</li> <li>• EPA_</li> <li>• UPA_</li> <li>• CDAM</li> <li>• MPC_</li> </ul>	Expertise
Archiving_Info/ARCHIVING_TIME	Processing/archiving date (UTC data time)	Expertise
Processing_Specific_Parameters/PROCESSING_SPECIFIC_PARAMETERS	Optional field reserved for production chain only (NOT propagated to User Product)	Expertise

The Geometric\_Info are the same provided for L1C Tiles.

Quality Indicators Info:

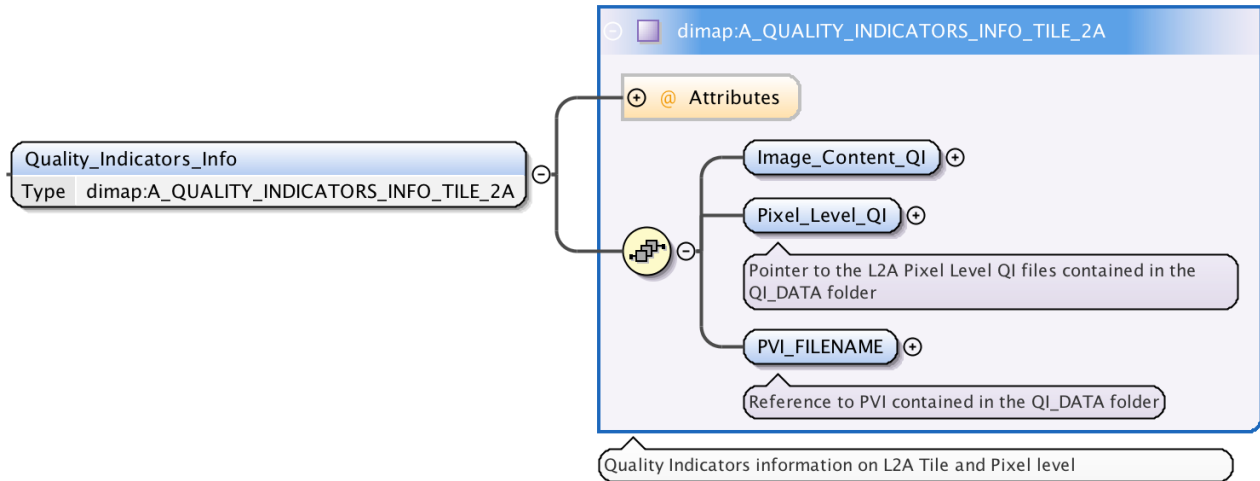

Figure 61: Level-2A\_Tile\_Metadata\_File – Quality\_Indicators\_Info Diagram

The following table describes the Quality Indicators provided for a Level-2A Tile PDI.

Quality_Indicators_Info		
Field Name	Description	Metadata Level
CLOUDY_PIXEL_PERCENTAGE	Percentage of cloud coverage provided for each Tile.	Standard
DEGRADED_MSI_DATA_PERCENTAGE	Percentage of degraded MSI data provided for each Tile.	Standard
NODATA_PIXEL_PERCENTAGE	Percentage of No Data (Missing data on projected tiles) pixels	Standard
SATURATED_DEFECTIVE_PIXEL_PERCENTAGE	Percentage of saturated or defective pixels	Standard
DARK_FEATURES_PERCENTAGE	Percentage of pixels classified as dark features or shadows	Standard
CLOUD_SHADOW_PERCENTAGE	Percentage of pixels classified as cloud shadow	Standard
VEGETATION_PERCENTAGE	Percentage of pixels classified as vegetation	Standard
NOT_VEGETATED_PERCENTAGE	Percentage of pixels classified as not-vegetated	Standard
WATER_PERCENTAGE	Percentage of pixels classified as water	Standard
UNCLASSIFIED_PERCENTAGE	Percentage of pixels classified as unclassified	Standard
MEDIUM_PROBA_CLOUDS_PERCENTAGE	Percentage of pixels classified as medium probability clouds	Standard

Quality_Indicators_Info		
Field Name	Description	Metatada Level
HIGH_PROBA_CLOUDS_PERCENTAGE	Percentage of pixels classified as high probability clouds	Standard
THIN_CIRRUS_PERCENTAGE	Percentage of pixels classified as thin cirrus clouds	Standard
SNOW_ICE_PERCENTAGE	Percentage of pixels classified as snow or ice	Standard
RADIATIVE_TRANSFER_ACCURACY	Declared accuracy of the radiative transfer model.	Standard
WATER_VAPOUR_RETRIEVAL_ACCURACY	Declared accuracy of the Water Vapour model	Standard
AOT_RETRIEVAL_ACCURACY	Declared accuracy of the Aerosol Optical Thickness model	Standard
Quality_Indicators_Info/Pixel_Level_QI		
Field Name	Description	Metatada Level
MASK_FILENAME	Pointer to the mask files contained in the QI_DATA folder: <ul style="list-style-type: none"> <li>- Finer cloud mask files</li> <li>- Technical quality mask files</li> <li>- Detector footprint mask</li> <li>- Radiometric quality masks</li> </ul>	Standard
PVI_FILENAME	Reference to PVI contained in the QI_DATA folder	

Table 65: Level-2A\_Tile\_Metadata\_File – Quality\_Indicators\_Info Description

### 3.13.2.2 IMG\_DATA (folder)

Level-2A processing consists in scene classification and atmospheric correction applied to Level-1C orthoimage product.

Level-2A main output is an orthoimage Bottom-Of-Atmosphere (BOA) reflectance product. Additional outputs are Aerosol Optical Thickness (AOT) map, Water Vapour (WV) map, Scene Classification map together with Quality Indicators data.

Level-2A products are resampled as Level-1C products with a constant GSD (Ground Sampling Distance) of 10 m, 20 m and 60 m according to the native resolution of the different spectral bands.

IMG\_DATA folder contains three resolution subfolders, each one containing images described in the following subsections.

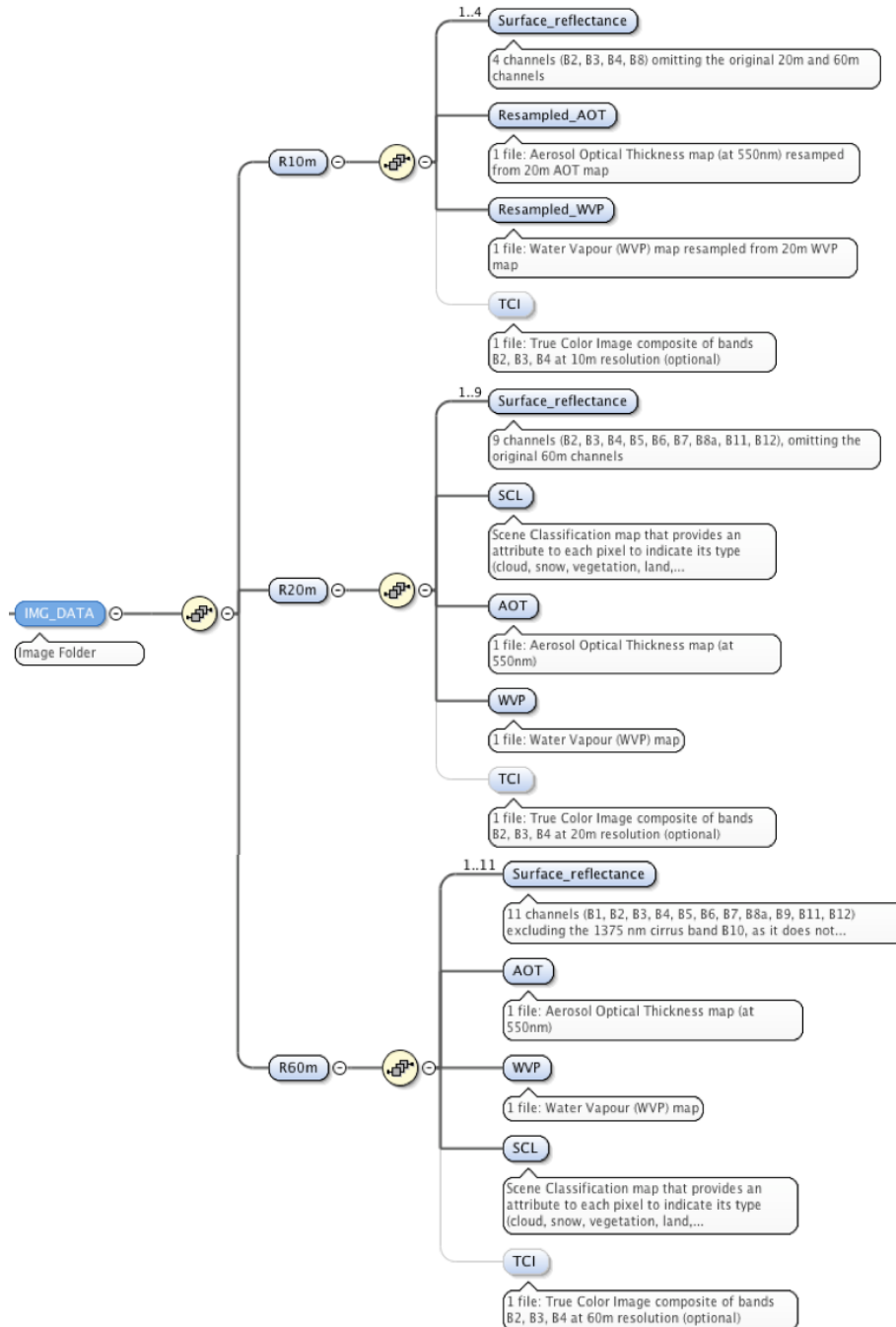

Figure 62: Level-2A Tile IMG\_DATA folder structure

### 3.13.2.2.1 Surface Reflectance images (JPEG2000)

The surface reflectance is computed using the “Sentinel-2 Atmospheric Correction” (Sen2Cor) algorithm and is based on reference radiative transfer code. Look Up Tables (LUTs) are based on LibRadtran.

File naming convention = <Tile>\_<Datatake\_Sensing\_Time>\_<Band\_Index>\_<Resolution>.jp2

Where:

Field	Signification	Length (max)	Example Value
Tile	According to US-MGRS naming convention. (Inherited from Level-1C tile)	6	32TNS
Datatake Sensing Time	This time refers to the sensing time of the first line of the PDI in UTC time. 15 digits, date and time, separated by the character T.	15	20171103T102201
Band_Index	Bxx where: xx = 01, 02, 03, 04, 05, 06, 07, 08, 8A, 09, 10, 11, 12	3	B04
Resolution	xxm where: xx = 10, 20, 60	3	20m

Table 66: Level-2A image files naming convention

Level-2A surface reflectance image file example name:

T32TNS\_20171103T102201\_B04\_20m.jp2

### 3.13.2.2.2 AOT images (JPEG2000)

The aerosol optical thickness retrieval is based on the dense dark vegetation (DDV) algorithm.

File naming convention = <Tile>\_<Datatake\_Sensing\_Time>\_<Band\_Index>\_<Resolution>.JP2

Where: Band\_Index = ‘**AOT**’, all other parameters as for Table 66.

Example of a S2 L2A AOT tile name:

T15SWC\_20160302T190048\_AOT\_10m.jp2

### 3.13.2.2.3 Water\_Vapour images (JPEG2000)

The water vapour retrieval over land is performed with the atmospheric pre-corrected differential absorption (APDA) algorithm.

File naming convention =

L2A\_<Tile>\_<Datatake\_Sensing\_Time>\_<Band\_Index>\_<Resolution>.JP2

Where: Band\_Index = ‘**WVP**’, all other parameters as for Table 66.

Examples of a S2 L2A Water Vapour tile name:

T15SWC\_20160302T190048\_WVP\_20m.jp2

### 3.13.2.2.4 Scene Classification images (JPEG2000)

The Scene Classification algorithm allows to detect clouds, snow and cloud shadows and to generate a classification map, which consists of 3 different classes for clouds (including cirrus), together with six different classifications for shadows, cloud shadows, vegetation, soils / deserts, water and snow.

The generated classification map is specified as follows:

Label	Classification
0	NO_DATA
1	SATURATED_OR_DEFECTIVE
2	DARK_AREA_PIXELS
3	CLOUD_SHADOWS
4	VEGETATION
5	BARE_SOILS
6	WATER
7	UNCLASSIFIED
8	CLOUD_MEDIUM_PROBABILITY
9	CLOUD_HIGH_PROBABILITY
10	THIN_CIRRUS
11	SNOW /ICE

The file naming convention for the Scene Classification image data is:

L2A\_<Tile>\_<Datatake\_Sensing\_Time>\_<Band\_Index>\_<Resolution>.JP2

Where: Band\_Index = 'SCL', all other parameters as for Table 66.

Examples of S2 L2A Scene\_Classification data:

T15SWC\_20160302T190048\_SCL\_20m.jp2

T15SWC\_20160302T190048\_SCL\_60m.jp2

### 3.13.2.2.5 True Colour Images (JPEG2000)

True colour images generated by the Level-2A processing will be included in the three resolution folders of IMG\_DATA.

File naming convention = <Tile>\_<Datatake\_Sensing\_Time>\_<Band\_Index>\_<Resolution>.jp2

Where: Band\_Index = 'TCI', all other parameters as for Table 66

Level-2A surface reflectance image file example name:

T15SWC\_20160302T190048\_TCI\_20m.jp2

### 3.13.2.3 QI\_DATA (folder)

QI\_DATA folder contains XML reports OLQC\_Report.xml generated by On-Line Quality Control processor, including Quality Control Checks results, GML quality mask files and JPEG2000 Preview\_Image file as listed in section 3.11.3.3, following naming convention of section 4.9.10. Moreover the QI\_DATA folder contains some specific L2A quality mask (image data files compressed using the JPEG2000 algorithm):

- Cloud probability map  
File naming = MSK\_CLDPRB\_20m.jp2 or MSK\_CLDPRB\_60m.jp2.  
The name is fixed.
- Snow probability map  
File naming = MSK\_SNWPRB\_20m.jp2 or MSK\_SNWPRB\_60m.jp2.  
The name is fixed.
- Dark Dense Vegetation pixels map (optional)  
File naming = MSK\_DDVPXL\_20m.jp2 or MSK\_DDVPXL\_60m.jp2.  
The name is fixed.



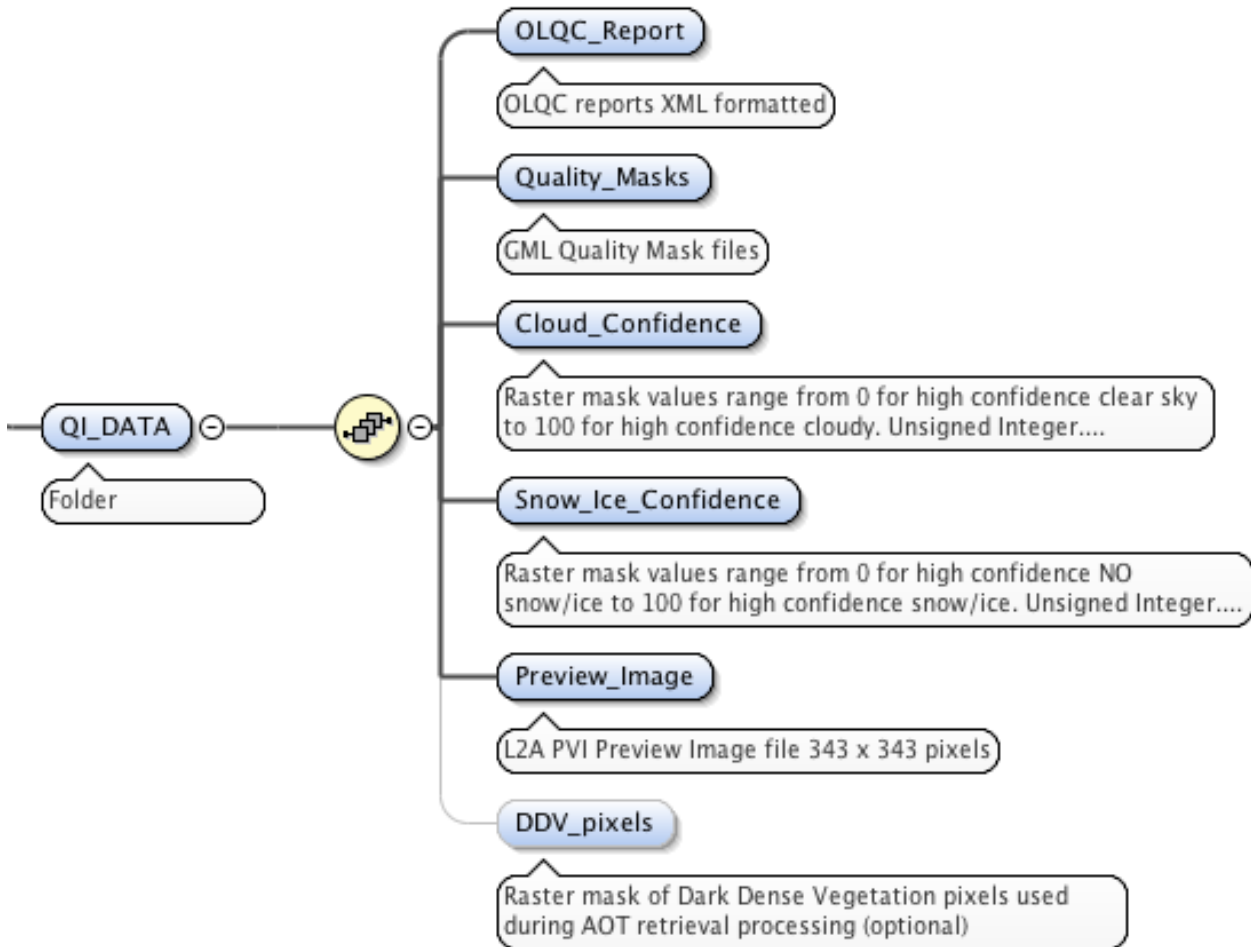

Figure 63: Level-2A Tile QI\_DATA folder structure

#### 3.13.2.4 AUX\_DATA (folder):

This folder contains ECMWF data in UTM projection (single file in GRIB V1 format). The naming convention is the same defined in section 4.9.10.

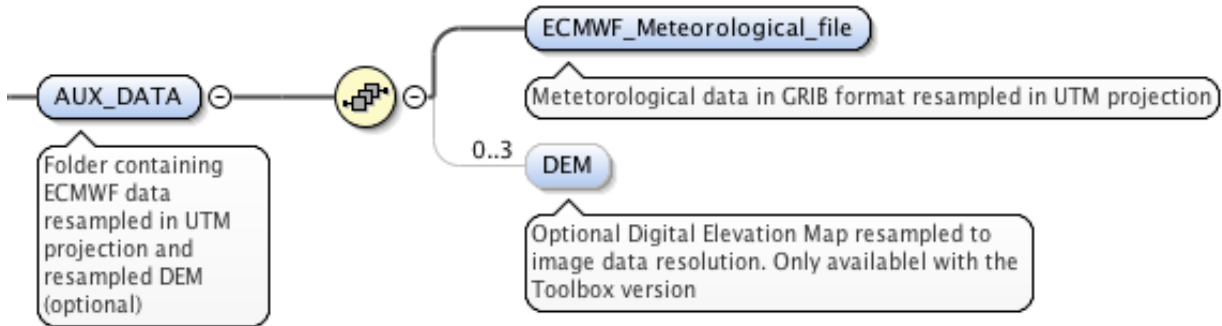

Figure 64: Level-2A Tile AUX\_DATA folder structure

### 3.14 Level-2A Datastrip PDI definition

Level-2A Datastrip PDI is defined as a **tar** file containing the following structure:

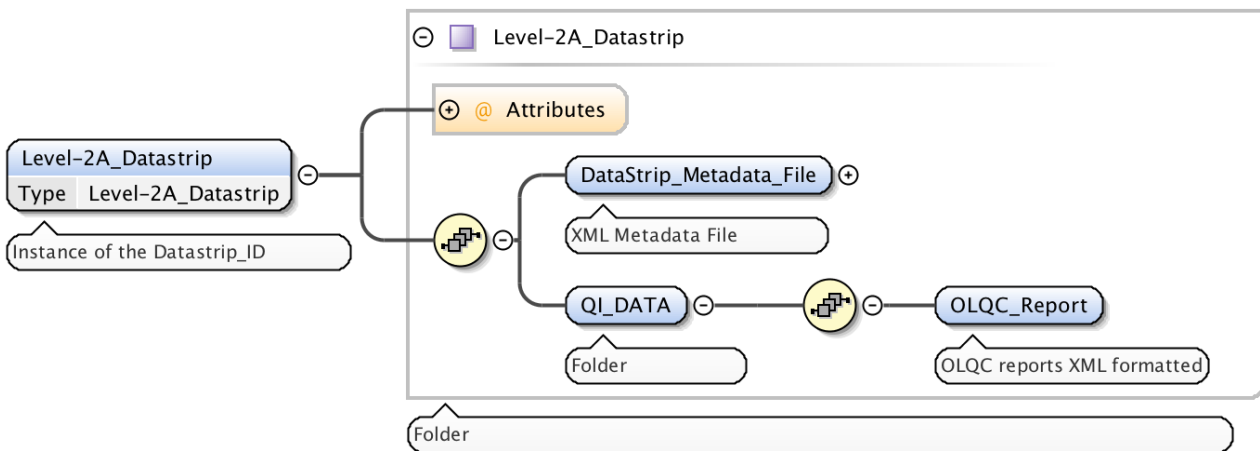

Figure 65: PDI Level-2A Datastrip Structure

The PDI Level-2A Datastrip consists of:

1. **Datastrip\_Metadata\_File**: XML metadata file containing the requested level of information and referring all the product elements composing the Datastrip,
2. **QI\_DATA**: folder containing XML reports including Quality control checks information,
3. **Inventory\_Metadata.xml**: file containing the metadata needed to inventory the PDI.

### 3.14.1 PDI\_ID definition

The PDI\_ID (Datastrip ID), used to identify a Level-2A Datastrip PDI, follows the description provided in the section 3.2 using the File\_Type field “MSI\_L2A\_DS”.

Level-2A Datastrip Template Name (Datastrip ID):

*S2A\_OPER\_MSI\_L2A\_DS\_SGS\_\_20141104T134012\_S20141104T134012\_N01.01*

Note that the PDI\_ID.tar is the physical name of the Datastrip PDI after the tar compression.

### 3.14.2 Level-2A Datastrip Physical Format

The PDI ID defined above represents the “Datastrip directory” name. Inside the Datastrip directory, there are the Datastrip components as in the Figure 66:

- **Datastrip\_Metadata\_File (XML file):**

The Datastrip\_Metadata\_File name is fixed in *MTD\_DS.xml*

The XSD schema which regulates the metadata file is *S2\_PDI\_Level-2A\_Datastrip\_Metadata.xsd* included in the *S2-PDGS-TAS-DI-PSD-VXX\_Schemas.zip* file annexed to the document.

- **QI\_DATA (folder):**

QI\_DATA folder contains XML reports *OLQC\_Report.xml* generated by On-Line Quality Control processor, including Quality Control Checks results. The *OLQC\_Report.xsd* schema are in the Annex C of the document. Naming convention follows 4.9.10

- **Inventory\_Metadata (XML file):**

XML inventory metadata file

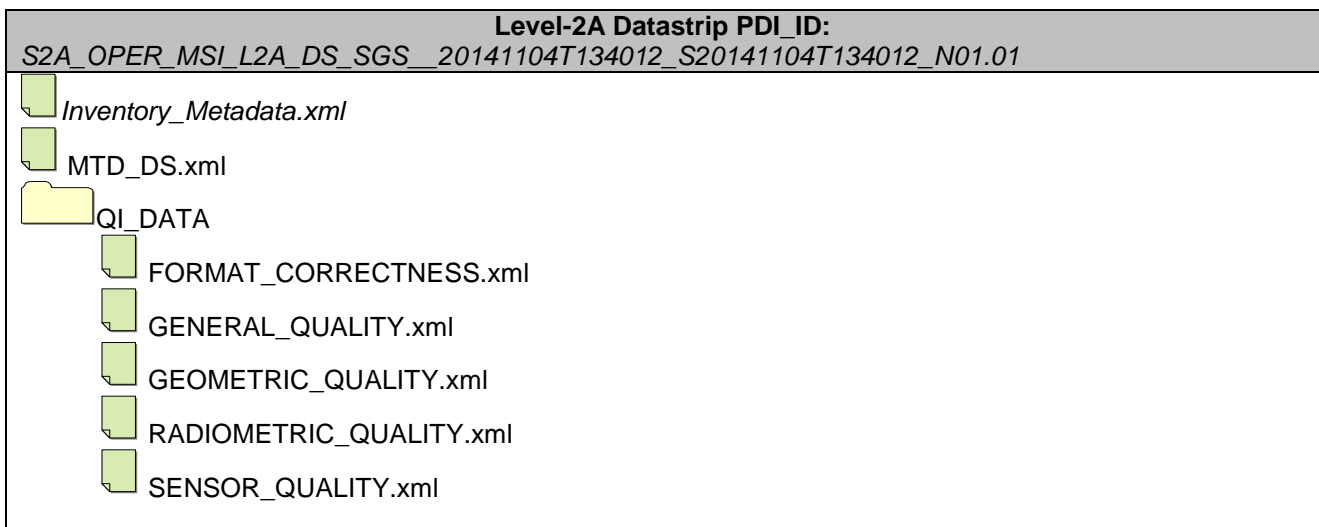
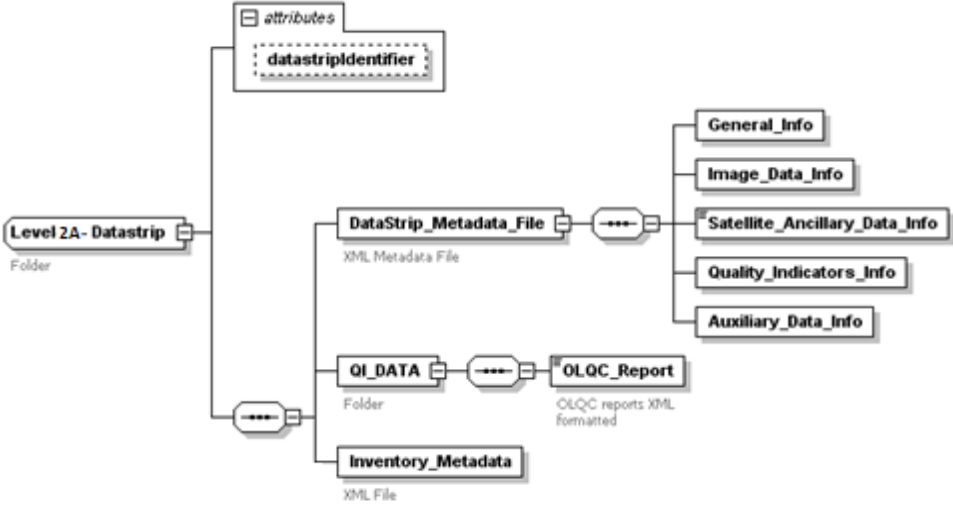

Figure 66: PDI Level-2A Datastrip Physical Format

### 3.14.3 Level-2A Datastrip PDI Structure

The *S2\_PDI\_Level-2A\_Datastrip\_Structure.xsd* schema annexed to the document and shown in the following diagram, represents the organization of a Level-2A Datastrip PDI on disk. This

schema is provided for information only as It is actually not expected to be used for the validation of a XML file.

<p>diagram</p>	
<p>children</p>	<p><a href="#">Datastrip_Metadata_File</a> <a href="#">OI_DATA</a> <a href="#">Inventory_Metadata</a></p>
<p>annotation</p>	<p>The Level-1C Datastrip is defined as a folder containing:</p> <ol style="list-style-type: none"> <li>3. <b>Datastrip_Metadata_File</b>: XML Main Metadata File containing the requested level of information and referring all the PDI elements.</li> <li>4. <b>OI_DATA</b>: folder containing the XML reports including Quality Indicators</li> <li>6. <b>Inventory_Metadata</b>: XML inventory metadata file</li> </ol> <p><u>Note that the Inventory_Metadata.xml, manifest.safe and rep_info are removed when the PDI is included in the User Product.</u></p>

### 3.14.3.1 Datastrip\_Metadata\_File Schema

Level-2A Datastrip\_Metadata\_File is the XML metadata file provided inside each Level-2A Datastrip. The schema used to validate is the *S2\_PDI\_Level-2A\_Datastrip\_Metadata.xsd* annexed to this document. For specific details regarding each metadata (e.g. type, default value, fixed value, enumerations, occurrences, etc...) refers to the XSD file. The Info provided in the L2A Datastrip metadata are the same provided for a L1C Datastrip (see 3.12.3.1) except for the following fields:

- Image\_Data\_Info/Radiometric\_Info/QUANTIFICATION\_VALUE (modified field): for the L2A are provided BOA Reflectances, Aerosol Optical Thickness and Water Vapor quantification values
- Auxiliary\_data\_Info/SNOW\_CLIMATOLOGY\_MAP (additional field): Reference to Snow Climatology Map used for Scene Classification
- Auxiliary\_data\_Info/ESACCI\_WaterBodies\_Map (additional field): Reference to Water Bodies Map used for Scene Classification
- Auxiliary\_data\_Info/ESACCI\_LandCover\_Map (additional field): Reference to Land Cover Map used for Scene Classification

- Auxiliary\_data\_Info/ESACCI\_SnowCondition\_Map\_Dir (additional field): Reference to Snow Condition Map Folder used for Scene Classification
- Auxiliary\_data\_Info/LUT\_List (additional field): Reference to libRadtran Look Up Tables used for Atmospheric Correction

### 3.14.3.2 QI\_DATA

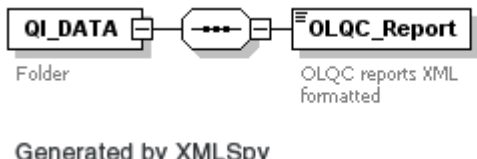
diagram	
children	<a href="#">OLQC_Report</a>
annotation	QI_DATA folder contains the XML reports generated by On-Line Quality Control processor, including Quality Control Checks results. Their file naming convention is described in section 4.9.10.

## 3.15 PDI for GIPP files definition

GIPP files are a set of files used by the processors to achieve radiometric and geometric parameters. Each GIPP file is associated to a validity period since the parameters can be tuned during the PDGS lifetime. All GIPP file types are listed in the Table 6.

The GIPP PDIs are downloaded in TGZ format including one file DBL and one file HDR as specified in [EOFFS-PDGS].

### 3.15.1 PDI-ID definition

The applicable file naming convention used to identify a GIPP PDI is compliant to [EOFFS-PDGS]:

PDI\_ID = MMM\_CCCC\_TTTTTTTTTT\_<instance\_id>

The sub-strings MMM (Mission ID), CCCC (File Class), and TTTTTTTTTT (File Type) are detailed in the section 3.2 Table 6. The Instance ID for a PDI relative to a GIPP file is defined hereafter.

<Instance\_Id> = <Site Centre>\_<Creation Date>\_<Start Validity Time >\_<Stop Validity Time >\_<Bxx>

<Site Centre> and <Creation Date> corresponding to the Instance\_ID mandatory prefix (cf. section 3.2).

<Site Centre>:

- MPC\_

The sub-fields composing the Instance\_ID are described in the following table:

Field Name	Value/Meaning	Note
Start Validity Time	VyyyymmddThhmmss	"V" is the option Id for validity period
Stop Validity Time	YYYYMMDDThhmmss	
Bxx	Band index xx = 01, 02, 03, 04, 05, 06, 07, 08, 8A, 09, 10, 11, 12  xx = "00" for GIPP files band independent	

Table 67: PDI-ID definition for GIPP files

File Template Name:

S2A\_OPER\_GIP\_VIEDIR\_MPC\_\_20091210T235100\_V20091210T235134\_20091210T235224\_B08

### 3.16 PDI for DEM file definition

The Image Quality Processor delivers the **System DEM (Digital Elevation Model)** that is composed of two layers (**Global Coarse DEM** and **SRTM DEM**) and a **Basis Geoid Model**.

**GLOBE DEM** gives an average altitude information (in meters) in all points of a global grid. The altitude is provided in the WGS84 reference frame, with respect to the ellipsoid.

The GLOBE DEM is divided in elementary areas of 1° x 1°, also called cells. Each cell, provided as a binary file, is limited by meridians (integers of longitude), and parallel (integers of latitude).

The goal of this file is to define an altitude information with an average value for all the point on a global grid with a kilometric resolution. Global size of the Globe DEM is roughly 800 MBytes.

**SRTM DEM** does not cover the entire globe. It covers 80% of land cover from the latitude 60° North to 56° South. The horizontal reference frame is WGS84. The altitude information is given in the geoid altimetric reference EGM96. Quality information are added to SRTM data through dedicated quality masks. The goal of this file (pseudostatic, supplied at beginning of mission and updatable 3 times during mission lifetime) is to provide a more accurate altimetry information (in meters). Global size of the SRTM DEM, respecting the DTED1 format, is roughly 50 GBytes.

Consistent with the GLOBE DEM, the **Geoid** is given in the WGS84 reference frame. The geoid is used to measure altitude and depth. The frequency is pseudostatic, supplied at beginning of mission via the CNES Euclidium CFI, single binary file of 131 MBytes.

The DEM is never included in the User Product but simply referenced through the metadata file.

### 3.16.1 PDI-ID definition

The PDI\_ID (file naming convention) used to reference the DEM within the User Product is compliant to [EOFFS-PDGS] and follows the description provided in the section 3.1:

PDI\_ID = MMM\_CCCC\_TTTTTTTTTT\_<Instance\_ID>.AAA

The sub-strings MMM (Mission ID), CCCC (File Class), and TTTTTTTTTT (File Type) are detailed in the section 3.2. The Instance ID for a DEM PDI it is defined hereafter.

<Instance\_Id> = <Site Centre>\_<Creation Date>\_<Start Validity Time>

<Site Centre> and <Creation Date> corresponding to the Instance\_ID mandatory prefix.

<Site Centre>:

- MPC\_

The sub-fields composing the Instance\_ID are described in the following table:

Field Name	Value/Meaning	Note
Start Validity Time	_SYYYMMDDTHHMMSS	<p>Taking into account that:</p> <ol style="list-style-type: none"> <li>1. GLOBE DEM is classified "pseudostatic" i.e. files supplied at beginning of mission and updatable with (TBD by CNES) frequency;</li> <li>2. SRTM DEM is classified "pseudostatic" i.e. files supplied at beginning of mission and updatable 3 times during mission lifetime as per CNES clarification;</li> <li>3. Geoid Model is classified "pseudostatic" i.e. files supplied at beginning of mission via the CNES Euclidium CFI and potentially updatable with TBD by CNES frequency via redelivery of the Euclidium CFI</li> </ol> <p>We can consider the option envisaged for file types whose Stop Validity is not relevant or it is always set to EOM and every new file replaces the previous one (cf. [EOFFS-PDGS] section 2.1.4.1).</p>

Table 68: PDI-ID definition for DEM

File Template Name:

S2\_\_OPER\_DEM\_GLOBEF\_MPC\_\_ 20091210T235100 \_S20091210T235100.tar

### 3.17 PDI for GRI definition

The Global Reference Images (GRI) is provided to the Sentinel-2 operational processor for the Level-1B product generation in order to refine the geometric accuracy. The GRI PDI is never included in the User Product but simply referenced through the metadata file. The GRI PDI definition (format and naming) is based on the [GRI-FFS].



The GRI PDI is defined as a TGZ file including the following structure. The naming for the “GRI Orbit Directory” and “Unitary Level-1B User Product” folders are defined in the next section.

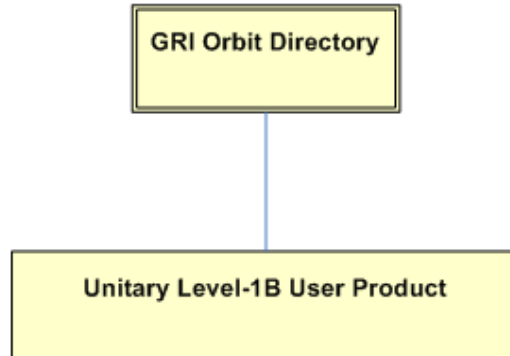

### 3.17.1 PDI-ID definition

The PDI\_ID (file naming convention) used to reference the GRI data within the User Product is defined according to [EOFFS-PDGS] and [GRI-FFS].

The PDI\_ID is the physical name of the “GRI Orbit Directory” defined according to [EOFFS-PDGS] [GRI-FFS]. It is used to reference the GRI data within the User Product at Datastrip level.

PDI\_ID = MMM\_CCCC\_TTTTTTTTTT\_<Instance\_ID>

The sub-strings MMM (Mission ID), CCCC (File Class), and TTTTTTTTTT (File Type) are detailed in the section 3.2.

<Instance\_Id> = <Site Centre>\_<Creation Date>\_<Validity\_Time\_Period>

Where:

<Site Centre> (equal to 'MPC\_') and <Creation Date> correspond to the Instance\_ID mandatory prefix (cf. section 3.1) and <Validity\_Time\_Period> is the applicability date.

<Validity\_Time\_Period> = \_VyyyymmddThhmmss\_YYYYMMDDTHHMMSS

Template:

S2\_\_OPER\_AUX\_GRI123\_MPC\_\_yyyymmddThhmmss\_VyyyymmddThhmmss\_YYYYMMDDTHHMMSS

The PDI\_ID with the TGZ extension identifies the physical name of the GRI PDI.

The naming convention for the “Unitary Level-1B User Product” is the same defined in the section 4.2 for a L1B User Product in SAFE format but with the filetype = GRI\_MSIL1B and Site Centre = MPC\_

Template:

S2A\_OPER\_GRI\_MSIL1B\_MPC\_\_20150424T120700\_R054\_V20090101T000000\_20181231T235959.SAFE

### 3.18 PDI for IERS Bulletin file definition

IERS Bulletin A contains Earth orientation parameters such as x/y pole, UTI-UTC and their errors at daily intervals and predictions for 1 year into the future. These values are needed for geometric transforms within the processing. When a IERS Bulletin A is published at day D0, its applicability date is retroactive to day D0-7. It remains valid until their next update. More precisely, their validity period is defined by the applicability date. The end of validity date is defined by the beginning of validity date of the posterior (i.e. next) bulletin.

The IERS Bulletin A is provided as an ASCII file on a weekly basis.

#### 3.18.1 PDI-ID definition

The PDI\_ID (file naming convention) used for a IERS Bulletin file, compliant to [EOFFS-PDGS] follows the description provided in the section 3.2:

PDI\_ID = MMM\_CCCC\_TTTTTTTTTT\_<Instance\_ID>

<Instance\_Id> = <Site Centre>\_<Creation Date>\_<Start Validity Time>\_<Stop Validity Time>

<Site Centre> and <Creation Date> corresponding to the Instance\_ID mandatory prefix (cf. section 3.2).

<Site Centre>:

- PDMC

The sub-fields composing the Instance\_ID are described in the following table:

Field Name	Value/Meaning	Note
Start Validity Time	VYYYYMMDDThhmmss	V prefix to indicate the validity period
Stop Validity Time	YYYYMMDDThhmmss	

Table 69: PDI-ID definition for IERS Bulletin

File Template Name:

S2\_OPER\_AUX\_UT1UTC\_PDMC\_YYYYMMDDTHHMMSS\_VYYYYMMDDTHHMMSS\_YYYYMMDDTHHMMSS.txt

### 3.19 PDI for POD file definition (deleted)

### 3.20 PDI for ECMWF data definition

This PDI contains raw ECMWF dataset in GRIB V1 format.

These data, resampled in UTM projection are always provided as part of Level-1C Tile PDI.

Note: the raw ECMWF data are not included in the User Product (no download option).

For further details regarding ECMWF data and GRIB V1 format see the reference document [GRIB].

### 3.20.1 PDI-ID definition

The PDI\_ID defined for a ECMWF PDI follows the description provided in the section 3.2:

PDI\_ID = MMM\_CCCC\_TTTTTTTTTT\_<Instance\_ID>

<Instance\_Id> = <Site Centre>\_<Creation Date>\_<Start Validity Time>\_<Stop Validity Time>

File Template Name:

S2\_\_OPER\_AUX\_ECMWFD\_PDMC\_YYYYMMDDTHHMMSS\_VYYYYMMDDTHHMMSS\_YYYYMMDDTHHMMSS

### 3.21 S2 HKTM PDI definition

House Keeping Telemetry (HKTM) PDI are routed to FOS after their generation at CGS. Spacecraft housekeeping telemetry is part of the ancillary data and is regularly downlinked to ground stations (every orbit). Raw VCDUs are provided with DFEP annotation as a separated file.

The HKTM PDI is formatted according to [SAFE-SPEC].

The PDI is defined as a **tar** file containing the following structure (representing the SAFE product structure):

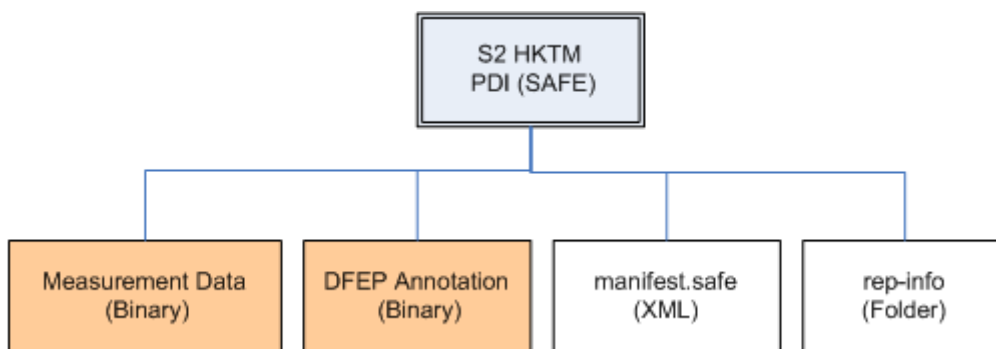

Figure 67: S2 HKTM PDI definition

As described in the figure, this Product Data Item consists of:

1. **Measurement Data file (Binary File)**: binary encoded file containing the stream of HKTM Transfer Frames TFs. The content of the housekeeping telemetry is detailed in [S2GICD]
2. **DFEP Annotation file (Binary File)**: binary file composed by one record for each HKTM TF, containing the TF annotations computed by the DFEP (cfr. [DFEP-ICD]).
3. **manifest.safe (XML File)**: manifest file that includes metadata information describing the overall context where the HKTM data are generated (mission, product history, timing, orbit, etc.) and providing information regarding the content and structure of the product, through references to the other components present in the product. An example of the *manifest.safe* relative to an HKTM product is in the annexed S2-PDGS-TAS-DI-PSD-V14\_SAFE.zip file .
4. **rep\_info (Folder)**: folder containing the XSD schemas related to the Measurement Data and DFEP Annotation.

#### 3.21.1 PDI-ID definition

The applicable file naming convention used for PDI relative to HKTM data is compliant to [EOFFS]:

PDI\_ID = MMM\_CCCC\_TTTTTTTTTT\_<instance\_id\*>

The sub-strings MMM (Mission ID), CCCC (File Class) are detailed in the section 3.2. The Instance ID for a PDI relative to a HKTM data is defined hereafter.

For HKTM PDIs, TTTTTTTTTT= 'PRD\_HKTM\_\_' (cf. Table 9)

<Instance\_Id\*> = <Valid UTC Start Time>\_<Valid UTC Stop Time>\_VVVV

Where:

<Valid UTC Start Time>: 8+6 digits, separated by "T"

<Valid UTC End Time>: 8+6 digits, separated by "T"

VVVV: four digit indicating the file version. Fixed to '0001' for HKTM PDIs

To identify the two binary files included in the tar structure the following naming convention is used:

Measurement Data (binary file) naming convention:  
HKTM\_PDI\_ID\_measurement

DFEP Annotation (binary file) naming convention:  
HKTM\_PDI\_ID\_annotation

Files Template Names:

HKTM PDI\_ID (physical name of the *tar* file):

S2A\_OPER\_PRD\_HKTM\_\_YYYYMMDDTHHMMSS\_YYYYMMDDTHHMMSS\_0001.tar

HKTM product name (physical name of the folder contained in the *tar* file):

S2A\_OPER\_PRD\_HKTM\_\_YYYYMMDDTHHMMSS\_YYYYMMDDTHHMMSS\_0001.SAFE

Measurement Data file:

S2A\_OPER\_PRD\_HKTM\_\_YYYYMMDDTHHMMSS\_YYYYMMDDTHHMMSS\_0001\_measurement.dat

DFEP Annotation file:

S2A\_OPER\_PRD\_HKTM\_\_YYYYMMDDTHHMMSS\_YYYYMMDDTHHMMSS\_0001\_annotation.dat

*manifest.safe*: fixed filename,

Measurement and Annotation schemas (located in the final leaf of the "resources" directory in the annexed zip file):

s2-level-0.xsd

s2-level-0-annot.xsd

### 3.22 SAD PDI definition

RAW Satellite Ancillary Data (SAD) data are systematically downlinked to ground stations at the end of each downlink as source packets provided with their DFEP annotation.

Each SAD packets include their corresponding source packet binary annotations as a pre-pended header. A source packet header consists (according to this order) in:

- DPC annotation computed during the L0 processing DPC annotation (cf. section 4.6.2.1);
- DFEP annotation as received from the DFEP (cf. [DFEP-ICD]).

SAD data (used mainly by the POD) are stored as a PDI.

A SAD PDI consists in a single *tar* file containing a set of unitary Raw SAD files each matching a single packet type defined in the Table 11. Those files cover the temporal extent of the full orbit.

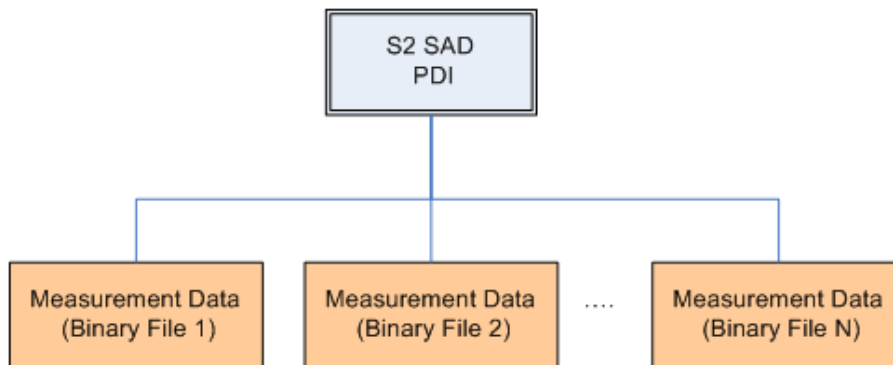

Figure 68: S2 SAD PDI definition

As described in the figure, the SAD PDI consists in a set of *Measurement Data* files (Binary Files), binary encoded files defined for each SAD type containing only a single source packets type. The content of the SAD telemetry is detailed in [S2GICD-SAD].

### 3.22.1 PDI-ID definition

SAD PDI is identified by a unique PDI\_ID (filename) following the description provided in the section 3.2:

PDI\_ID = MMM\_CCCC\_TTTTTTTTTT\_<instance\_id>.tar

The sub-strings MMM (Mission ID), CCCC (File Class), and TTTTTTTTTT (File Type) are detailed in the section 3.2 and Table 11. The tar contains a set of unitary Raw SAD files, one for each SAD type (39 different types expected in nominal cases, up to 53 different types with normally disabled SAD enabled) defined in the Table 11.

The Instance ID is defined hereafter.

<Instance\_Id> = <Site Centre>\_<Creation Date>\_<Sensing Start Time>\_<Sensing Stop Time >\_<Absolute Orbit Number>\_<Completeness>\_<Integrity>.tar

<Site Centre> and <Creation Date> corresponding to the Instance\_ID mandatory prefix (cf. section 3.2).

<Site Centre>:

- MTI\_ assigned to Matera CGS
- SGS\_ assigned to Svalbard CGS
- MPS\_ assigned to Mas Palomas CGS

The sub-fields composing the Instance\_ID are described in the following table:

Field Name	Value/Meaning	Note
Sensing Start Time	VYYYYMMDDThhmmss	"V" = option Id for validity period
Sensing Stop Time	YYYYMMDDThhmmss	
Orbit Number	Axxxxxx  xxxxxx = (000001-999999)	"A" = option Id for Absolute orbit number
Completeness	<b>Wx</b>  where: x = <b>F</b> for Full orbit x = <b>P</b> for Partial orbit	"W" = option Id for Completeness Id
Degradation	<b>Ly</b>  where: y = <b>N</b> for Nominal data (no degradation) y = <b>D</b> for Degraded data (some missing packets, due to synchro loss or corrupted telemetry)	"L" = option Id for Degradation Id

Table 70: PDI-ID definition for SAD

SAD PDI\_ID template:

S2A\_OPER\_AUX\_SADATA\_SGS\_\_YYYYMMDDTHHMMSS\_VYYYYMMDDTHHMMSS\_YYYYMMDDTHHMMSS\_A123456\_WF\_LN.tar

Measurement Data file (binary file) template:

S2A\_OPER\_AUX\_S11125\_SGS\_\_YYYYMMDDTHHMMSS\_VYYYYMMDDTHHMMSS\_YYYYMMDDTHHMMSS\_A123456\_WF\_LN.bin

### 3.23 TCI PDI definition

The set of PDIs related to the True Colour Images (TCIs) are stored separately in their own PDIs. True Colour Image PDI is defined as a **tar** containing the following structure:

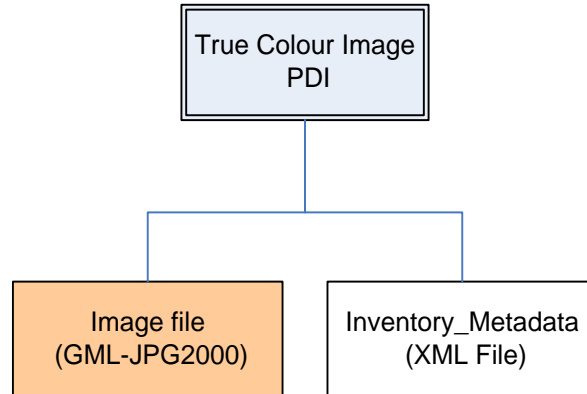

Figure 69: TCI PDI definition

As shown in the figure, the TCI PDI consists of:

- Image file: (GML-JPEG2000). The GML-JPEG2000 implementation is detailed in the reference document [GMLJP2]. It is a single file in JP2 format which gathers the 3 RGB bands.
- Inventory\_Metadata file: XML inventory metadata file.

It is identified by a unique PDI-ID defined in the following section.

#### 3.23.1 PDI-ID definition

The PDI\_ID (file naming convention) used for a TCI PDI, compliant to [EOFFS-PDGS] follows the description provided in the section 3.11.1 relative to a Level-1C Tile PDI. The File Type MSI\_L1C\_TC is defined in the section 3.2.



## 4. USER PRODUCT PHYSICAL FORMAT DEFINITION

This section contains the definition of the physical structure and format for each Sentinel-2 User Products.

### 4.1 S2 User Product Physical Format

The following table summarizes for each S2 User Products the expected content and format. Note that the User Product structure is common to all processing level (L0/L1A/L1B/L1C/L2A) except for the Satellite Ancillary Data provided only inside a Level-0 User Product.



## Sentinel-2 Products Specification Document

REF : S2-PDGS-TAS-DI-PSD  
 ISSUE : 14.5  
 DATE : 14/03/2018  
 PAGE : 314 / 510

Product Main Components	Physical Format	Mandatory	L0	L1A	L1B	L1C	L2A	Description
Product_Metadata_File	XML file	Y	Y	Y	Y	Y	Y	This is the mandatory XML metadata file that describes the physical organization and the content of the User Product.
manifest.safe	XML file	N	Y	Y	Y	Y	Y	The <i>manifest.safe</i> file will be included in the User Product only if the user requires the product SAFE formatted.  Note that the User Product contains only one main <i>manifest.safe</i> file. The <i>manifest.safe</i> files relevant to each Granules/Datastrips composing the product are available at PDI level but they are not included in the User Product, all lower manifest files at PDI level are removed.
GRANULE	Folder	Y	Y	Y	Y	Y	Y	This is a folder of folders. In fact it contains the list of the Granule composing the product. For each Granule is provided a folder with a structure similar to the one defined in the chapter 3 and named as the Granule PDI_ID (Granule ID). This product main component is the core of the User Product containing the imaging data files.
DATASTRIP	Folder	Y	Y	Y	Y	Y	Y	Folder containing the list of folders corresponding each one to the Datastrips composing the product named as the Datastrip PDI_ID (Datastrip ID).
AUX_DATA	Folder	Y	Y	Y	Y	Y	Y	Folder containing the set of auxiliary files that can be embedded in the User Product if selected by the user. All the auxiliary files used for the processing are referenced at metadata level.
ANC_DATA	Folder	Y	Y	N	N	N	N	Folder containing the SAD raw data (ancillary data source packets) provided inside a single file. In order to have the maximum coverage of the raw SAD in the L0 User Product, the latest SAD related to the downlink time will be embedded in the product.
Browse_Image	PNG file	N	Y	Y	Y	Y	Y	The Browse Image is included in the User Product if required by the user (download option). The Browse Image is based on the PVI extracted from





**Sentinel-2 Products  
Specification Document**

REF : S2-PDGS-TAS-DI-PSD  
 ISSUE : 14.5  
 DATE : 14/03/2018  
 PAGE : 315 / 510

Product Main Components	Physical Format	Mandatory	L0	L1A	L1B	L1C	L2A	Description
								the Level-1C Tiles PDI (JPEG2000, low resolution extraction, 3 visible-bands in ground geometry at 320m resolution, RGB).
rep_info	Folder	N	Y	Y	Y	Y	Y	Folder containing the XSD schemas describing the User Product components. This folder is optional. It will be included in the User Product if the user selects the SAFE format as output format (cf. section 4.5).
INSPIRE	XML file	Y	Y	Y	Y	Y	Y	Metadata file based on INSPIRE Metadata regulation ([EC-INSPIRE-CR] and [EC-INSPIRE-DIR]).
HTML	Folder	Y	Y	Y	Y	Y	Y	Folder containing: 1. UserProduct_index.html 2. UserProduct_index.xsl 3. Additional files for HTML displaying The first file is a product presentation file allowing the End User to display easily the main content of the product. The second one represents the stylesheet used to generate the first one allowing the End User to display a selected sub-set of the product metadata. In addition some files are provided for correctly displaying the HTML page.

Table 71: Sentinel-2 Products Physical Format



Note that the User Product metadata provides different views of information and its content is organised at three levels:

- **Product level:** general information provided at product level. These metadata are grouped in the Product\_Metadata\_File described in the following sections for each processing level.
- **Granule/Tile level:** information referring to the Granules/tiles (or portion of Granule, i.e. the pixel-level information) composing the User Product. These metadata, (located in the User Product inside the GRANULE/Granule\_Metadata\_File), are embedded as they are from the Granule PDIs to the User Product.
- **Datastrip level information:** information referring to the Datastrip composing the User Product. These metadata (located in the User Product inside the DATASTRIP/Datastrip\_Metadata\_File), are embedded as they are from the Granule PDIs to the User Product.

For details regarding metadata management see section 2.10.

#### 4.1.1 User Product XSD Schemas

This section contains the list of the XSD schemas (annexed to the document) used to describe the physical structure and the metadata content of each S2 User Product:

1. *S2\_User\_Product\_Level-0\_Structure.xsd*
2. *S2\_User\_Product\_Level-1A\_Structure.xsd*
3. *S2\_User\_Product\_Level-1B\_Structure.xsd*
4. *S2\_User\_Product\_Level-1C\_Structure.xsd*
5. *S2\_User\_Product\_Level-2A\_Structure.xsd*
  
6. *S2\_User\_Product\_Level-0\_Metadata.xsd*
7. *S2\_User\_Product\_Level-1A\_Metadata.xsd*
8. *S2\_User\_Product\_Level-1B\_Metadata.xsd*
9. *S2\_User\_Product\_Level-1C\_Metadata.xsd*
10. *S2\_User\_Product\_Level-2A\_Metadata.xsd*

The first set of the schemas (points 1 - 4) define the "physical organization" of a User Product on the disk.

These schemas are "improperly" used to specify elements not envisaged by the XML such as folders, therefore it is actually not expected to be used for the validation of the corresponding XML file.

Oppositely, the second set of the schemas (points 5 – 12) are used to validate the XML metadata file inside each S2 User Product (SAFE and DIMAP formatted).

#### 4.2 S2 User Product Naming Convention

The naming of the **product name root directory** is compliant to [EOFFS-PDGS] and follows the naming convention defined hereafter:

MMM\_CCCC\_TTTTTTTTTT\_<Instance\_ID>.<FORMAT> where:

Part	Description	Comment
MMM	<b>Mission ID</b>	S2A S2B
CCCC	<b>File Class</b>	4 uppercase letters: OPER for Routine Operations (all phases)  Note that the File Class will be set "OPER" for all products generated during the operation phase. During validation or for internal testing other values can be defined

TTTTTTTTTT	<b>File Type</b> (File Category + File Semantic)	10 uppercase letters can contain digits and underscores: PRD_MSIL0P PRD_MSIL1A PRD_MSIL1B PRD_MSIL1C PRD_MSITCI
<Instance_ID>	<b>Instance Id</b>	Contains uppercase letters, digits and underscores.
<FORMAT>	<b>SAFE</b> <b>DIMAP</b>	According to the User Product output format selected by the final user.

Table 72: Main Product Directory - Naming Convention

< instance ID> = ssss\_yyyymmddThhmmss\_ROOO\_VYYYYMMTDDHHMMSS\_YYYYMMTDDHHMMSS

where:

sss\_yyyymmddThhmmss is the <Instance ID> mandatory prefix for Site Centre of the file originator and Creation Date.

Sub-String	Description	Comment
sss	Site Centre	Fixed string with value "PDMC"
<Product Discriminator>	String generated to ensure the uniqueness of the product name root directory in the use-base file-system	Default value for the <i>product discriminator</i> is the creation date of the product at the user base following this format <i>yyymmddThhmmss</i>
OOO	Orbit Number	Relative orbit number
YYYYMMDDHHMMSS	Start Time	Sensing Time of the first line of the first scene in the product
YYYYMMDDHHMMSS	Stop Time	Sensing sTime of the first line of the last scene in the product

The fixed characters "\_R" and "\_V" are defined in the section 3.2.

Examples of S2 product main directory are:

S2A\_OPER\_PRD\_MSIL0P\_PDMC\_20130424T120700\_R054\_V20091210T235100\_20091210T235134.SAFE  
S2A\_OPER\_PRD\_MSIL1A\_PDMC\_20130424T120700\_R055\_V20091210T235052\_20091210T235143.SAFE  
S2B\_OPER\_PRD\_MSIL1B\_PDMC\_20130424T120700\_R056\_V20091210T235052\_20091210T235143.DIMAP

Inside the product directory we have the product main components listed in the Table 4-1.

- **Product\_Metadata\_File (mandatory, XML Main Metadata file):**  
The product metadata file name follows the same convention defined for the main product directory where the File Type field is defined in the following table:

Product component	FileType	Note
-------------------	----------	------

Product_Metadata_File	MTD_SAFLOP MTD_SAF1A MTD_SAF1B MTD_SAF1C	Valid if the User Product is SAFE formatted  L2A user product are only SAFE_COMPACT
	MTD_DMPL0P MTD_DMPL1A MTD_DMPL1B MTD_DMPL1C	Valid if the User Product is DIMAP formatted  L2A user product are only SAFE_COMPACT

Table 73: Product\_Metadata\_File - Naming Convention

File Template name:

S2A\_OPER\_MTD\_DMPL1A\_PDMC\_20130424T120700\_R054\_V20091210235100\_20091210235134.xml

- **manifest.safe (optional, XML file):**

XML file with fixed name *manifest.safe*.

- **GRANULE (folder):**

GRANULE folder contains the list of folders each one corresponding to the Granules composing the User Product. The name (PDI\_ID) and the content (structure of *tar*) of each folder are defined in the chapter 3 for Level-0/Level-1A/Level-1B/Level-1C Granule/Tile.

In case of Level-1C User Product, the GRANULE folder contains N folders each one corresponding to the Tiles composing the product.

As defined in the section 3.11, for each tile there is a single folder named IMG\_DATA where the image data files are available one for each band.

During the Level-1C User Product generation, according to the *Spectral Bands* download options, the IMG\_DATA folder can contain a set of bands and/or the TCI corresponding to the Tile. The TCI can be requested into the User Product even if no other spectral band data has been selected.

The filename of the image data files present in the Tile folders is defined in the section 3.11.2.

The filename of the TCI is based on the image data filename of the *Spectral Bands* with filetype equal to MSI\_L1C\_TC and the band qualifier "Bxx" defined by the string "TCI".

For instance, image data filename:

S2A\_OPER\_MSI\_L1C\_TL\_MTI\_\_20160615T115939\_A005123\_T36RVT\_B01.jp2

TCI filename:

S2A\_OPER\_MSI\_L1C\_TC\_MTI\_\_20160615T115939\_A0051233\_T36RVT\_TCI.jp2

- **DATASTRIP (folder):**  
DATASTRIP folder contains the list of folders each one corresponding to the Datastrips composing the User Product. The name (PDI\_ID) and the content (structure of *tar*) of each folder are defined in the chapter 3 for Level-0/Level-1A/Level-1B/Level-1C Datastrip.
- **AUX\_DATA (folder):**  
AUX\_DATA folder contains the set of auxiliary files that can be embedded in the User Product if selected by the user (download option). The folder can contain GIPP files and/or IERS bulletin (cf. section 2.13). All other kind of auxiliary data used for the processing are referenced at metadata level. The naming convention used to identify each auxiliary file is defined in the chapter 3 for each PDI-Type Auxiliary:
  - GIPP
  - DEM
  - GRI
  - ECMWF
  - IERS
- **ANC\_DATA (folder):**  
ANC\_DATA folder contains the raw Satellite Ancillary Data (SAD) provided as a set of unitary raw data files each one matching a single packet type and named as defined in the section 3.22.1. The SAD coverage is the same of the one in the last Datastrip selected to be included in the product.
- **Browse\_Image (optional, PNG file):**  
The Browse Image file name follows the same convention defined for the main product directory where the File Type field is defined in the following table.  
For each level of User Product has been defined a specific Browse Image File Type. The Browse Image when available within a User Product is always based on the PVI generated for the corresponding L1C Tiles.

Product component	FileType	Note
Browse_Image	BWI_MSIL0P BWI_MSIL1A BWI_MSIL1B BWI_MSIL1C BWI_MSITCI	Overview of the product (sub-sampled) mainly for image data browsing and selection purposes

Table 74: Product\_Metadata\_File - Naming Convention

File Template name:

S2A\_TEST\_BWI\_MSIL1A\_PDMC\_20130424T120700\_R054\_V20091210235100\_20091210235134.png

- **rep\_info (folder):**  
Folder with fixed name recommended by [SAFE-SPEC].
- **INSPIRE.xml (mandatory, XML file):**  
XML file with fixed name.
- **HTML (folder):**



This folder contains two files:

1. UserProduct\_index.html
2. UserProduct\_index.xsl

The first file is a product presentation file allowing the End User to display easily the main content of the product.

The second one represents the stylesheet used to generate the first one allowing the End User to display a selected sub-set of the product metadata.

### 4.2.1 Compact Naming Convention

The *Compact Naming Convention* is a download option which assigns compact names to the Sentinel-2 User Products to overcome the limitation of some Operative System file-systems regarding the maximum length of the files full path.

The longest full path length used to refer to any User Product component for Level-1C products is 141 characters considering the overall product tree compacting addressing the different internal files and folders.

The longest full path length for Level-0, Level-1A and Level-1B products is 230 characters considering that compacting of the name applies only to the root directory.

The compact naming convention impacts only the names of files and folders composing the product but not its structure defined in previous sections of this document.

For Level-1C/Level-2A products, the Compact Naming Convention optimises the entire product tree structure whereas for Level-0, Level-1A and Level-1B such convention applies only to the root directory of the product name.

#### 4.2.1.1 Product Name Root Directory

In case of *products generated with the Compact Naming convention*, the **Product Name Root Directory** is defined as follows:

MMM\_MSIXXX\_YYYYMMDDHHMMSS\_Nxxyy\_ROOO\_<Product Discriminator>.SAFE

where:

- MMM: is the mission ID (S2A/S2B)
- MSIXXX : MSIL1C for reference to the Level-1C product level/ MSIL2A for reference to the Level-2A product level
- YYYYMMDDHHMMSS: it is the datatake sensing start time
- Nxxyy: it is the production baseline number (e.g. N0201)
- ROOO: it is the relative orbit number
- <Product Discriminator>: it is a 15-characters string discriminator to distinguish different end user products associated to the same datatake
- SAFE file extension

Below some examples of different product root directory names following this naming convention:

S2A\_MSIL1B\_20150802T105414\_N0102\_R008\_20150803T124046.SAFE

S2A\_MSIL1C\_20150802T105414\_N0102\_R008\_20150803T124046.SAFE

### 4.3 User Product Quality Indicators

The Quality Indicators (QI) provided inside the User Product are:

1. QI at GRANULE level for each Granule composing the product;
2. QI at DATASTRIP level for each Datastrip composing the product;
3. QI at User Product level including:
  - 3a) QI consolidated from information available at Granules level:
    - o cloud coverage % = AVG(Granule level cloud coverage indicator)
    - o technical quality % = AVG(Granule level technical quality indicator)
  - 3b) reference to all OLQC reports (cf. Annex C) containing the **FAILED** checks performed on the Granules and Datastrips composing the product.
  - 3c) QI representing a synthesis of the OLQC inspections performed at Granule and Datastrip level.

More details regarding the needed processing to compute the QIs at product level, are in the Table 4-12.

### 4.4 Download Options

The download options proposed to the user at the time of the User Product selection are shown in the following table:

Download Options												
S2 User Product	Area Of Interest	Full Swath	Full Datasake	PVI	Auxiliary Data	Metadata Level	Spectral Bands	Consolidated Tiles	Aggregation Along-Track	Output Format	Single Tile Product	Complete Single Tile
Level-0	YES	YES	YES	YES	YES	YES	YES	NO	NO	YES	NO	NO
Level-1A	YES	YES	YES	YES	YES	YES	YES	NO	YES	YES	NO	NO
Level-1B	YES	YES	YES	YES	YES	YES	YES	NO	YES	YES	NO	NO

Download Options												
S2 User Product	Area Of Interest	Full Swath	Full Datatake	PVI	Auxiliary Data	Metadata Level	Spectral Bands	Consolidated Tiles	Aggregation Along-Track	Output Format	Single Tile Product	Complete Single Tile
Level-1C	YES	NO	YES	YES	YES	YES	YES (*) TCI option	YES	NO	YES	YES	YES
Level-2A	YES	NO	YES	YES	YES	YES	YES (*) TCI option AOT/WVP/SCL option	YES	NO	NO (Level-2A products can be packaged only in SAFE_COMPACT format)	YES	YES

- **Area Of Interest:** query option which describes exactly the area drawn by the User during the selection of the product.
- **Full Swath:** option to extend automatically the user selected area to the full MSI swath.
- **Full Datatake:** option to extend automatically the user selected area to the full Datatake.
- **PreView Image (PVI<sup>2</sup>):** option to include in the final Product the Browse Image corresponding to the selected User Product.
- **Auxiliary Data:** option to include in the User Product the auxiliary data used for processing. By default, a S2 product contains the list of used auxiliary data referenced at metadata level.
- **Metadata Level:** option to select the level of metadata (Brief/Standard/Expertise) to include in the User Product.
- **Spectral Bands:** this option allows to lower the volume of data to download, selecting a given subset of spectral bands. For Level-1C products, the TCI image can be selected as part of this download option as it were any other spectral band.
- **Consolidate Tiles:** using this option, the user may request to receive only complete L1C Tiles that have been consolidated (cf. Section 4.9.8).
- **Aggregation Along-Track:** this option allows to merge for each detector one image grouping all single Granules along track therefore producing at maximum 12 images per band. (cf. Section 4.7.8).
- **Output Format:** option to package the User Product in SAFE or DIMAP format for the traditional naming or SAFE\_COMPACT when compact short naming is desired.
- **Single Tile Product Packaging:** this option allows to generate Single UTM Tile coverage Level-1C/Level-2A User Products from every product download request (i.e. original download request can be related to several tiles).
- **Complete Single Tile:** this option allows to include as part of the Single Tile Level-1C/Level-2A User Product all the full data associated to every single Tile in terms of any

<sup>2</sup>The “Browse Image” is here referenced as “PreView Image” to be aligned with the ngEO terminology.

kind of imagery and metadata. This option tailors the single tile naming convention to ensure a deterministic and repeatable name of the product in case of download of the same tile. The Complete Single Tile does not include auxiliary data and BWI.

#### 4.5 User Product SAFE Format Approach

The User Product is formatted by default as a **SAFE** (Standard Archive Format for Europe) product.

Following the User Product presentation in the Table 71, a SAFE User Product includes a **manifest.safe** file and a **rep\_info** folder according to [SAFE-SPEC].

The *manifest.safe* is an XML file formatted according to [SAFE-SPEC] providing metadata (concerning the overall context where the User Product is generated and the User Product itself) and a map of the User Product content (consisting in a reference to all data components inside the product including measurement data files, ancillary and auxiliary data files, XSD schema, etc).

The *manifest.safe* is composed by three main sections:

Manifest sections	Description
<b>Information Package Map</b>	Contains a high-level textual description of the product and references to all products components.
<b>Metadata Section</b>	Contains the product Metadata, including the product identification and the resource references.
<b>Data Object Section</b>	Contains references to the physical location of each component file contained in the product, with a description of the file format, location, size and checksum.

Table 75: High Level Structure of SAFE Manifest File

More in details the *manifest.safe* contains:

1. metadata information defined by [SAFE-SPEC] including not only the mandatory Metadata Sections (Platform and Processing sections) but, as added value, other relevant non mandatory Metadata Sections (e.g. acquisitionPeriod, measurementOrbitReference, measurementFrameSet),
2. a sub-set of metadata redundant respect to the mandatory XML Product\_Metadata\_File included in the User Product,
3. the map of the complete content of the User Product, namely all the references to all product component files (including the reference to the XML main metadata file) with the description of each file (e.g. file type, file size, coding, etc...).

Note that the Product\_Metadata\_File file groups all metadata regarding the product and the mission context, while the SAFE Manifest file contains, as added value, the exhaustive map of the User Product itself and a description of each file User Product components (e.g. file type, file size, coding, etc...).

In this respect, the present document provides, for each L0/L1A/L1B/L1C User Product defined in this Section 4, the following information:

- A set of 3 tables (one for each of the three main sections), containing the list of fields (tags or attribute) to be included in the Safe Manifest file, and for each field:
  - the field name in the SAFE Manifest file (attributes names are in bold character);
  - only for the Metadata section, the corresponding field name in the Product\_Metadata\_File schema; this column highlights the redundant sub-set of metadata included both in the XML Product\_Metadata\_File and in the XML SAFE Manifest file;
  - a brief textual description of the field;
  - the data type of the field;
  - the occurrence of the field (min/max occurrence e.g. 0..1); a minimum occurrence of 1 means that the field is mandatory.
- A practical example of SAFE Manifest file containing the tags listed in the table mentioned above. Each tag is set to an indicative value, as realistic as possible; the compliance of the SAFE Manifest file to the SAFE specification has been verified by validating the Manifest file against the SAFE XSD schemas. All SAFE Manifest files and the schemas are provided in the zip file (S2-PDGS-TAS-DI-PSD-V14\_SAFE.zip) annexed to this document. The XSD schemas are provided as a set of *xudu.xsd* schemas located in the final leaf of the *resources* directory.

In addition to the mandatory SAFE Manifest file, according to the applicable document [SAFE-SPEC], a SAFE User Product contains the *rep\_info* folder (fixed folder name recommended by [SAFE-SPEC]) including all the available schemas describing the product component files. Those schemas are not mandatory but "may be provided" inside the product.

The XSD schemas provided inside the *rep\_info* folder are referenced as internal product components by "metadataComponentSchemas" tag in the manifest file.

On the contrary, according to the SAFE specifications, the XSD schemas used to validate the SAFE manifest files are not included in the *rep\_info* folder but they are external to the User Product.

Note that the User Product contains only one main SAFE Manifest file and one *rep\_info* schemas repository. The Manifest files and *rep\_info* repositories related to each Granules/Datastrips composing the product are available at PDI level but they are not included in the User Product. All lower level manifest files and *rep\_info* folders are removed before to build the User Product. SAFE does not authorise multiple SAFE manifest and SAFE schema repository in a product.

## 4.6 Level-0 User Product specification

### 4.6.1 Introduction

The Level-0 User Product is generated from the Sentinel-2 instrument and ancillary telemetries. It contains raw data after restoration of the chronological data sequence at full space/time resolution with all auxiliary and ancillary information to be used in subsequent processing. In fact the Level-0 product contains all the information required to generate the Level-1 (and upper) product levels. The Level-0 consolidation processing stores the Quick Look image in the L0 Datastrip PDI. Reprocessing is from archived consolidated L0 which include QL image to get Level 1 products.

One Level-0 product refers always to one Datatake; it can cover the full Datatake or an its extract. It may refer to one or several Datastrips from the same Datatake.

The following figure gives an overview of the Level-0 User Product physical format. The yellow boxes correspond to folders and the white ones to files:

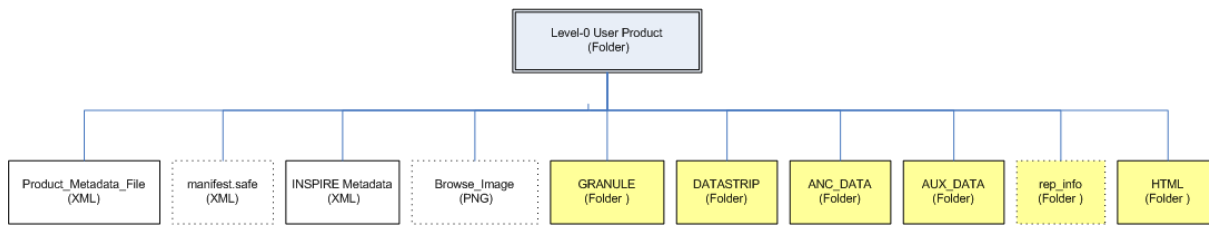

Figure 70: Level-0 User Product Structure

The Level-0 User Product consists of:

1. **Product\_Metadata\_File**: mandatory XML main metadata file.
2. **manifest.safe**: SAFE metadata file (optional). It is included in the product only if the user requests the SAFE as output format (download option).
3. **GRANULE**: folder containing all Granules composing the product (Image Data). The Image Data files inside each Granule are provided as a set of 13 binary files, one image file per band corresponding to a given detector.
4. **DATASTRIP**: folder containing the Datastrip composing the product linked to the selected Granules.
5. **AUX\_DATA**: folder containing, if requested by the user (download option), the GIPP files and IERS Bulletins used for the Level-0 User Product production. All Level-0 auxiliary data are referenced in the product metadata file.
6. **ANC\_DATA**: folder containing the Satellite Ancillary Data (SAD) needed for the processing (GPS data, attitude data, etc.). The SAD are always provided as a set of unitary Raw Data files each matching a single packet type. Those files are provided on the same temporal extent of the SAD embedded in the last Datastrip selected to be included in the product.
7. **rep\_info**: folder containing the XSD schema provided inside the product. This folder is optional. It is included in the User Product if the user selects the SAFE format as output format (download option).

8. **Browse\_Image**: PNG file consisting of an image limited to 3 visible-bands in ground geometry at 320m resolution. This file, provided if required by the user (download option), gives an overview of the product (sub-sampled) mainly for image data browsing and selection purposes.
9. **INSPIRE**: XML INSPIRE metadata file (cf. Annex B).
10. **HTML**: folder containing an HTML product presentation file (UserProduct\_index.html) and the corresponding stylesheet (UserProduct\_index.xsl).

Note: The number of the Granules available within a L0 product is variable and driven by the active detectors list specified at Datastrip level (ACTIVE\_DETECTOR metadata).

The list of the active detectors depends on the MSI acquisition mode (compression by-passed or not).

Compression mode is reported in the MSI packet by the MODOP field (cf. [S2GICD-MSI]).

In the nominal products the compression is enabled and all detectors are available; in case of calibration products the compression is by-passed and only a subset of detectors are active and therefore available.

## 4.6.2 Image Data

### 4.6.2.1 Data Organization

The image data, inside the Level-0 User Product, are organized per Granules. Each Granule contains the mission data corresponding to one on-board scene for one detector and all spectral bands. Therefore, as described in the section 3.5.5, the image data inside each Level-0 Granule, are provided as a set of 13 binary files, one for each spectral band, including all corresponding annotated Image Source Packets (ISP) in the observation chronological sequence (cf. [S2GICD-MSI]).

For instance, a Datatake of 220 scenes (approx. 5000km) contains  $220 \times 12 = 2640$  Granules corresponding to  $2640 \times 13 = 34320$  binary files.

The L0 ISPs contain data part and annotations (note that the annotation must be removed before uncompressing during L1 processing).

The data part correspond to MSI compressed data or not inline with the indication in COMPRESS\_MODE metadata. ISPs include their corresponding source packet annotations as a pre-pended header of each source packet. The annotations provided with the ISP (see following table) are the result of the following operations performed on each ISP:

- Reed-Solomon (RS) corrections on all Transfer Frames (TFs) containing the ISP;
- Checks if there are missing TFs by checking anomalies in the sequence of the Virtual Channel Frame Count in the Primary Header;
- CRC Error check on the ISP;
- DPC checks.

Note: even if L0 unconsolidated (L0u) are no User Products, ISP furnished in L0u are also annotated.

An annotation is made in two parts:

- first the DPC part;
- then the DFEP part.

The DPC part is 2 bytes long and contains:

- a "packet to be ignored" flag indicating if packet has to be ignored (value set to 1) or to be taken into account (value set to 0), on 1 bit: this indicator regroups all possible packets to be ignored;
- a "packet completeness" flag on 1 bit, set to:
  - 0 if packet complete;
  - 1 if packet is incomplete but long enough to be processed (therefore "packet to be ignored" flag is set to 0);
  - 1 if packet is incomplete and too short (not to be taken into account for further processing, therefore "packet to be ignored" flag is set to 1);
- a "packet validity" flag on 1 bit, set to:
  - 0 for valid packet (good CRC);



- 1 if CRC is invalid but packet is declared trustworthy (main information of the header are all correct, "packet to be ignored" flag is set to 0);
- 1 if CRC is invalid and packet is not trustworthy (not to be taken into account for further processing, therefore "packet to be ignored" flag is set to 1);
- the 13 bits remaining are reserved.

The DFEP part, 18 bytes long, is fully described in the [DFEP-ICD]:

Field ID	Description
<b>mjd_time_stamp</b>	Downlink/ground reception time. The time stamp is the downlink time of the first transfer frame containing parts of the packet
<b>isp_length</b>	Size in bytes of the ISP after reconstruction from transfer frames (it may be less than the initial size of the ISP in case of missing transfer frames)
<b>num_VCDUs</b>	Number of Transfer Frames containing the current ISP
<b>num_missing_VCDUs</b>	Number of missing Transfer Frames containing the current ISP
<b>crc_error_flag</b>	CRC Error flag, indicating the detection of CRC error in the ISP
<b>VCID</b>	First bit is set to 1 if VCID field contains VCID, 0 otherwise. 1 bit of spare. 6 bits containing the VCID
<b>Channel</b>	Channel information: C1/C2 01 (binary): C1 10 (binary): C2
<b>Spare</b>	

Table 76: DFEP Annotations for one Instrument Source Packet

The original downlinked data stream at ISP level is preserved but corrupted ISPs are flagged; i.e. corrupted ISPs are not discarded, but simply marked as such (field "packet to be ignored" of the DPC annotation set to 1).

DFEP also considers an ISP corrupted (and the corresponding DFEP annotation field `crc_error` set to TRUE) in one of the following cases:

- if one or more TFs containing the ISP are missing or found incorrigible during Reed-Solomon decoding (`num_missing_VCDUs` field in Table 1 > 0). In this case, the ISP is extracted, but the successive CRC error check on the packet detects an error, and the field `CRCFlag` is set to TRUE;
- if the CRC error check detects an error in the extracted ISP e.g. due to packet corruption after generation on-board by the source packet terminal.

#### 4.6.2.2 Volume

Each .Granule has a constant volume of approximately **16 MB** and contains image data with the same time stamp but spatially deregistered due to the interband deregistration of 14km at maximum.

Level-0 data is kept on-board compressed. The following table describes the contents of a Granule in term of number of mission source packets in a Granule.

SSD	Number of bands	Number of packet per band in one Granule
-----	-----------------	--

10 m	4	144
20 m	6	72
60 m	3	24

Table 77: Number of mission source packets in a Granule

Each Level-0 Granule is identified in a unique way, using a unique identifier PDI\_ID defined in the section 3.5.6.

#### 4.6.3 Ancillary Data

Raw Satellite Ancillary Data (SAD) are provided inside the Level-0 User Product within the ANC\_DATA folder. SAD data (DPC and DFEP annotated source packets, cf. §4.6.2.1) are splitted in binary files divided by PRID and SID (cf. Table 11). In order to have the maximum coverage of the raw SAD in the L0 User Product, the latest SAD related to the downlink time will be embedded in the product.

The decoded SAD, useful for further processing are provided at Datastrip level through the Datastrip metadata file. In particular, these data allow computing the associated geometric model and include:

- Time Correlation Data (sampled at 1Hz),
- Imaging orbit number,
- Ephemeris data,
- Attitudes data (sampled at 10Hz):
- Thermal data

#### 4.6.4 Auxiliary Data

All Auxiliary Data used for the Level-0 processing are referenced in the product metadata file:

- IERS bulletin file,
- Ground Image Processing Parameters (GIPPs) files (cf. Annex D),
- Reference to used DEM.

The final user, according to a specific download option, will be able to include in the its Level-0 User Product, the IERS bulletin and/or the used GIPP files. DEM is never provided within the product but only referenced at metadata level.

#### 4.6.5 Quality Indicators

The Quality Indicators (QI) are made available by the consolidation processing for the Level-0 product.

The *Product Level Quality Indicators* are provided at product level through the product metadata file.

The *Granule Level Quality Indicators* are provided at Granule level through the metadata file.

The *Datastrip Level Quality Indicators* are provided at Datastrip level through the metadata file.

The User Product QI are defined in the Table 4-12.

#### 4.6.6 Metadata

The following table shows the groups of metadata provided inside a Level-0 User Product:

Level-0 User Product Metadata	
<b>Product Level Metadata</b>	All product level metadata, specific for the User level, are consolidated/computed because not present at Granule and Datastrip level.
<b>Granule Level Metadata (Brief/Standard/Expertise)</b>	All Brief/Standard/Expertise metadata (download option, cf. section 4.4) defined at Granule level are copied from the input Granules to the User Product.
<b>DATASTRIP Level Metadata (Brief/Standard/Expertise)</b>	All Brief/Standard/Expertise metadata (download option, cf. section 4.4) defined at Datastrip level are copied from the input Datastrips to the User Product;

Table 78: Level-0 Product Metadata

As mentioned in the section 2.10, the User Product metadata (all) are not provided with a *metadataLevel* attribute (Brief/Standard/Expertise) unlike what happens for all Granule and Datastrip metadata.

During the User Product assembling, this attribute is used to select by filtering, according to a download option, the set of metadata that must be included in the User Product.

For these filtered fields, the *metadataLevel* attribute is not written in the User Product's metadata.

Note that a User Product for an expert user (Expertise download option) will contain all level of metadata (Brief/Standard/Expertise). A User Product for a user with "Standard" or "Brief" permission will contain only Brief/Standard or Brief metadata.

In addition to the metadata in the table above, the User Product contains the *manifest.safe* metadata (when the User Product is SAFE format) and the INSPIRE metadata.

The Level-0 Product Metadata are detailed in the section 4.6.7.

#### 4.6.7 User Product Level-0 Structure

S2\_User\_Product\_Level-0\_Structure.xsd schema annexed to the document and shown in the following diagram represents the structure of a S2 Level-0 User Product. This schema is provided for information only as it is actually not expected to be used for the validation of a XML file. The diagram reflects exactly the Figure 60.

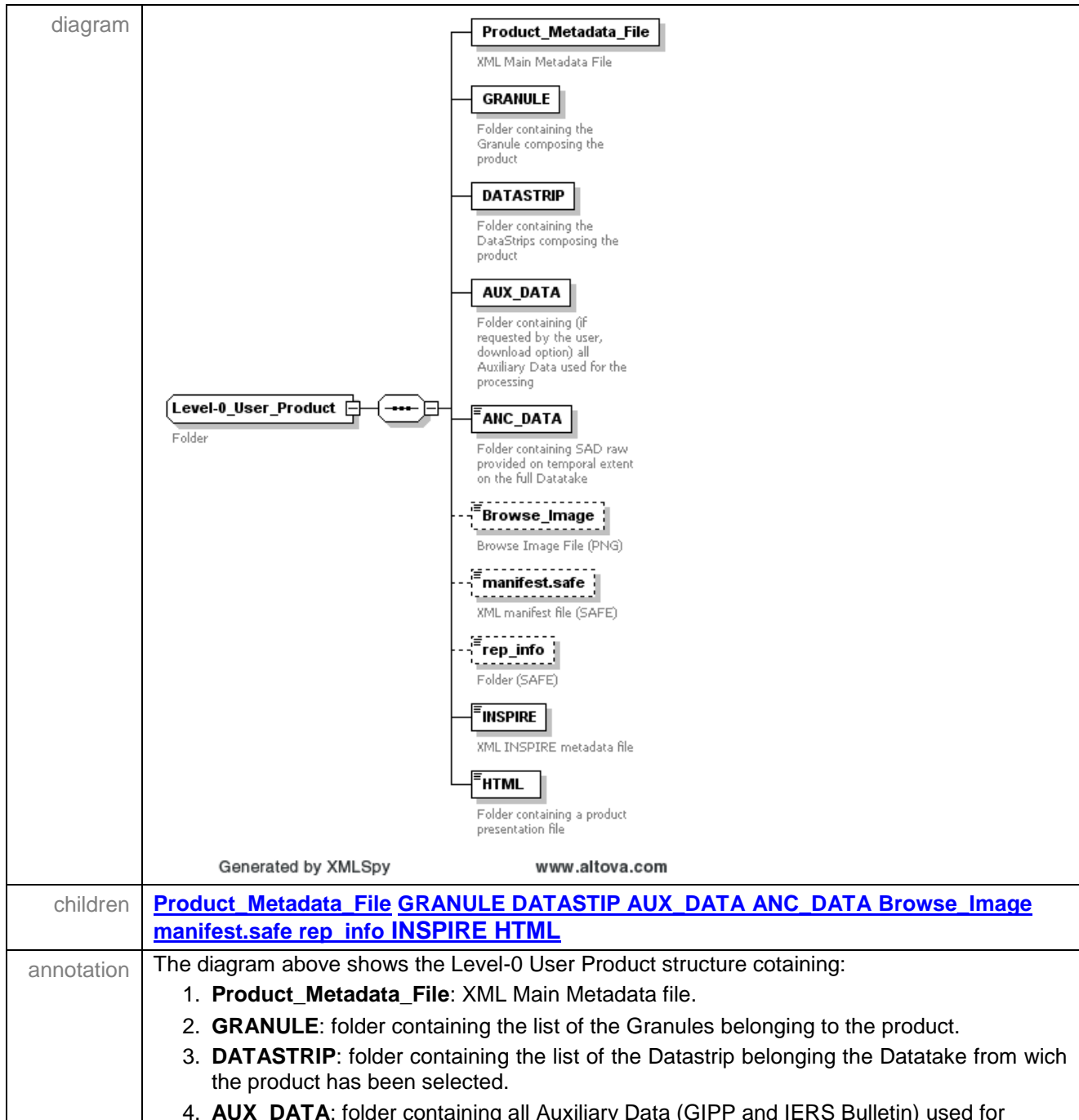

Level-0 processing (optional, the aux data are included in the product if selected according to a specific download option).

5. **ANC\_DATA**: folder containing Satellite Ancillary Data needed for processing (GPS data, attitude data, etc ....).
6. **Browse\_Image**: PNG file for image data browsing and selection purposes.
7. **manifest.safe**: XML SAFE Manifest file
8. **rep\_info**: optional folder containing the XSD schema
9. **INSPIRE.xml**: XML INSPIRE metadata file
10. **HTML**: folder containing an HTML product presentation file and the corresponding stylesheet.

#### 4.6.7.1 Product\_Metadata\_File Schema

Product\_Metadata\_File is the XML metadata file provided inside the S2 Level-0 User Product. The XSD schema annexed to this document and used to validate it is *S2\_User\_Product\_Level-0\_Metadata.xsd*.

A detailed description of the schema is given here but for specific details regarding each metadata (e.g. type, default value, fixed value, enumerations, occurrences, etc...) refers to the XSD file.

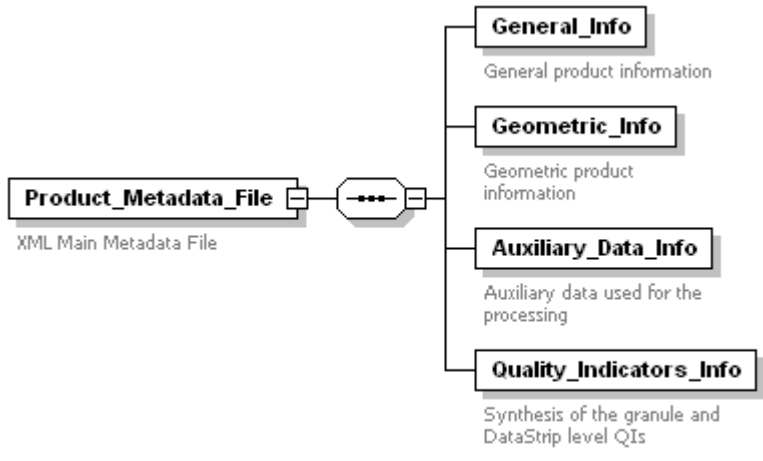
diagram	 <p align="center">Generated by XMLSpy <span style="float:right">www.altova.com</span></p>
children	<a href="#">General_Info</a> <a href="#">Geometric_Info</a> <a href="#">Auxiliary_Data_Info</a> <a href="#">Quality_Indicators_Info</a>
annotation	<p>Product_Metadata_File is an XML file containing:</p> <ol style="list-style-type: none"> <li>1. <b>General_Info</b>: this group of metadata provides general product information.</li> <li>2. <b>Geometric_Info</b>: these metadata provide information describing the geolocation over WGS84 of the contour of the product.</li> <li>3. <b>Auxiliary_Data_Info</b>: All the auxiliary data (GIPP and IERS Bulletin) used for the processing are here referenced.</li> <li>4. <b>Quality_Indicators_Info</b>: Synthesis of the Granule and Datastrip level QIs.</li> </ol>

The following figures and tables give a complete description of the User Product metadata.

General Info:

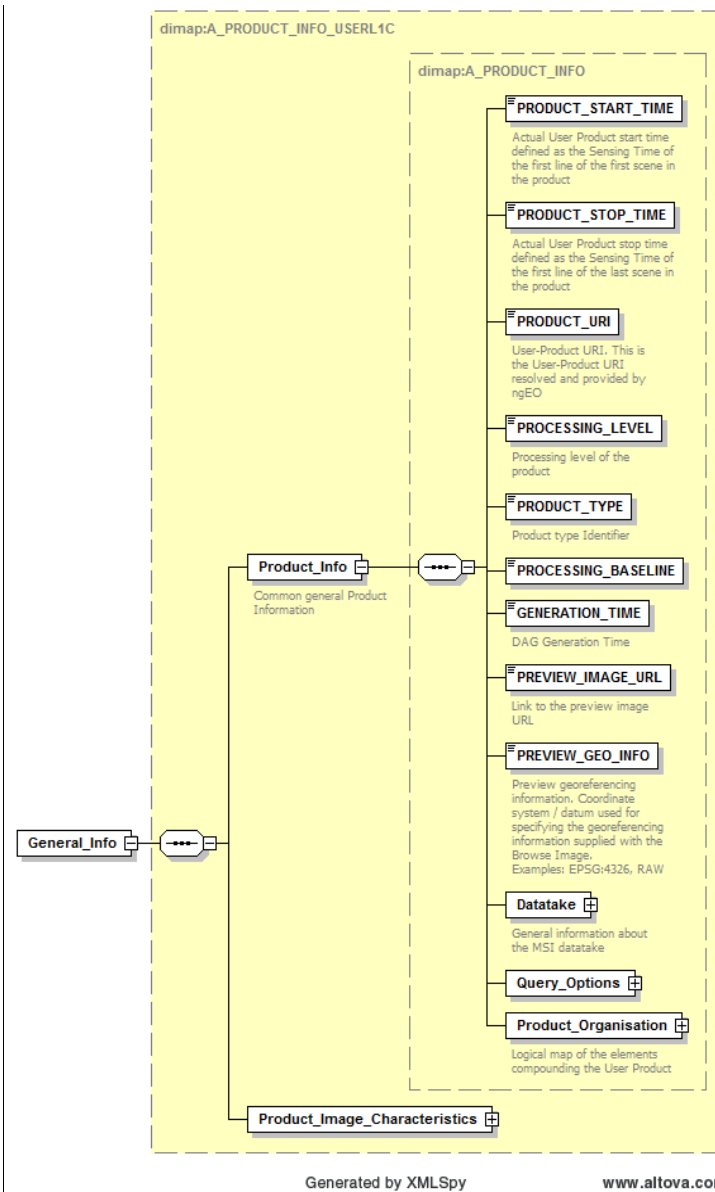

Figure 71 : Level-0 Product\_Metadata\_File - General\_Info Diagram



Legend for the Table 79:

- **Field Name:** provides the name used to identify the metadata;
- **Description:** contains a short description of the related metadata;
- **From Datastrip PDI:** indicates that the metadata at product level is filled using the corresponding information available at Datastrip level (from the Datastrip\_Metadata\_File of the Datastrip PDIs composing the product);
- **From Granule PDI:** indicates that the metadata at product level is filled using the corresponding information available at Granule level;
- **From Additional Processing:** indicates that the metadata, specific to the product level, does not originate neither from the Granules nor from the Datastrips composing the product but it is computed during the User Product assembling because not present at PDI level.

Note: The first section of the table (General\_Info (common section) is common to all processing level. The last section (Product image characteristics section) is specific for a Level-0 User Product.

General_Info (common section)					
Field Name	Description	From Datastrip PDI	From Granule PDI	From Additional Processing	Note
PRODUCT_START_TIME	Actual User Product start time defined as the Sensing Time of the first line of the first scene in the product		X	X	Based on the Sensing Start Time of the first scene
PRODUCT_STOP_TIME	Actual User Product stop time defined as the Sensing Time of the first line of the last scene in the product		X	X	Based on the Sensing Start Time of the last scene
PRODUCT_URI	This is the User Product URI resolved and provided by the catalogue ngEO. If the URI from ngEO is not available the field is set to the EUP name			X	User Product URI resolved and provided by



**Sentinel-2 Products  
Specification Document**

REF : S2-PDGS-TAS-DI-PSD  
 ISSUE : 14.5  
 DATE : 14/03/2018  
 PAGE : 338 / 510

General_Info (common section)					
Field Name	Description	From Datastrip PDI	From Granule PDI	From Additional Processing	Note
					ngEO
PROCESSING_LEVEL	Processing level of the product (Level-0)			X	Extracted from PDI filetype
PRODUCT_TYPE	Product type Identifier: S2MSI0 S2MSI1A S2MSI1B S2MSI1C S2MSI2A			X	Extracted from PDI_ID
PROCESSING_BASELINE	Processing Baseline	X			cf. Table 3-32
GENERATION_TIME	Product generation time			X	End time of product generation
PREVIEW_IMAGE_URL	Link to the preview image URL If the URL from ngEO is not available the field is set to N/A			X	Provided by ngEO
PREVIEW_GEO_INFO	Preview georeferencing information. If the information from ngEO is not available the field is set to N/A  Note: L1C/L2A User Product: browse image footprint covering the complete L1C/L2A User Product extent. L0/L1A/L1B : N/A			X	Provided by ngEO
Datatake/SPACECRAFT_NAME	Sentinel-2 Spacecraft name: Sentinel-2A Sentinel-2B	X			cf. Table 3-32
Datatake/DATATAKE_TYPE	MSI operation mode	X			cf. Table 3-32





**Sentinel-2 Products  
Specification Document**

REF : S2-PDGS-TAS-DI-PSD  
 ISSUE : 14.5  
 DATE : 14/03/2018  
 PAGE : 339 / 510

General_Info (common section)					
Field Name	Description	From Datastrip PDI	From Granule PDI	From Additional Processing	Note
Datatake/DATATAKE_SENSING_START	Imaging Start Time (Sensing start time of the Datatake)	X			cf. Table 3-32
Datatake/SENSING_ORBIT_NUMBER	Imaging Orbit Number	X			cf. Table 3-32
Datatake/SENSING_ORBIT_DIRECTION	Imaging Orbit Direction (Default = Ascending)	X			cf. Table 3-32
Query_Options/@ <i>completeSingleTile</i>	attribute indicating if the complete single tile download option was activated or not. <b>In case of completeSingleTile="true" all the Query_options are omitted except for Query_Options/PRODUCT_FORMAT</b>			X	
Query_Options/Area_Of_Interest/Bbox	Bounding Box (rectangle) which describes exactly the area drawn by the User during the selection of the product.  Defined by:  LOWER_CORNER: Coordinates position (2D, Lat/Lon) of the minimal point (bottom right) within the envelope  UPPER_CORNER: Coordinates position (2D, Lat/Lon) of the maximal point (upper left) within the envelope (This Field is omitted in case of completeSingleTile = "true")			X	Extracted from product URI provided by ngEO
Query_Options/Area_Of_Interest/Polygon	Polygon (simple and without holes) which describes exactly the area drawn by the User during the selection of the product.  Defined by:			X	Extracted from product URI provided by ngEO





**Sentinel-2 Products  
Specification Document**

REF : S2-PDGS-TAS-DI-PSD  
ISSUE : 14.5  
DATE : 14/03/2018  
PAGE : 340 / 510

**General\_Info (common section)**

Field Name	Description	From Datastrip PDI	From Granule PDI	From Additional Processing	Note
	EXT_POS_LIST: List of coordinates position (2D, LAT/LON) of the exterior points describing the surface boundary of the polygon. The polygon must be closed (the first and last vertices are the same). (This Field is omitted in case of completeSingleTile = "true")				
Query_Options/Area_Of_Interest/Radius	Circular area which describes exactly the area drawn by the User during the selection of the product.  Defined by:  CENTER: Center coordinates position (2D, Lat, Lon)  RADIUS_LENGTH: Radius expressed in meters (This Field is omitted in case of completeSingleTile = "true")			X	Extracted from product URI provided by ngEO
Query_Options/FULL_SWATH_DATATAKE	Flag to extend the user selected area to the full MSI swath (L0/L1A/L1B) or the full Datatake (L0/L1A/L1B/L1C/L2A). (This Field is omitted in case of completeSingleTile = "true")			X	Option managed at ngEO server level
Query_Options/Band_List/BAND_NAME	Option to select a given sub-set of spectral band to be embedded in the product.  In case of Level-1C User Product this option allow to embed in the product also the TCI corresponding to each TILE. (This Field is omitted in case of completeSingleTile = "true")		X	X	From product URI provided by ngEO containing Download Option flag



**General\_Info (common section)**

Field Name	Description	From Datastrip PDI	From Granule PDI	From Additional Processing	Note
Query_Options/Metadata_Level_List/METADATA_LEVEL	<p>List of metadata levels (Brief/Standard/Expertise). The End User, according to this download option, will be able to select the set of metadata at Granule and Datastrip level to be included in the User Product.</p> <p>NOTE: 1. option <u>Brief</u> means that metadata <i>Brief</i> will be included in the User Product; 2. option <u>Standard</u> means that metadata <i>Brief&amp;Standard</i> will be included in the User Product; option <u>Expertise</u> means that metadata <i>Brief&amp;Standard&amp;Expertise</i> will be included in the User Product. (This Field is omitted in case of completeSingleTile = "true")</p>	X	X	X	From product URI provided by ngEO containing Download Option flag (for instance: ngEO_DO={ ...,metadata Level:STANDARD,...})
Query_Options/Aux_List	<p>The final user, according to this download option, will be able to select the auxiliary data to be embedded in the User Product:</p> <ul style="list-style-type: none"> <li>• GIPP files (Link to GIPP files to embed in the product)</li> <li>• IERS (Link to IERS Bulletin files to embed in the product)</li> </ul> <p>Note: Raw ECMWF never downloaded (no embedding option); DEM never downloaded (no embedding option); GRI never downloaded (no embedding option);</p> <p>(This Field is omitted in case of completeSingleTile</p>	X			The product URI provided by ngEO indicates if the aux data have to be embedded in the User Product ( ngEO_DO={ ...,auxData: YES,...})  If YES, the

**General\_Info (common section)**

Field Name	Description	From Datastrip PDI	From Granule PDI	From Additional Processing	Note
	= "true")				list of aux files to be embedded in the User Product is copied from Datastrip PDI.
Query_Options/PREVIEW_IMAGE <sup>3</sup>	Option to include the Browse Image (if available) inside the User Product.  The Browse Image as URL is always embedded in the product. Only the physical file is optional. (This Field is omitted in case of completeSingleTile = "true")			X	From product URI provided by ngEO containing Download Option flags. The flag corresponding to this option is "pvi". (for instance: ngEO_DO={ ...,pvi:YES,, ...})
Query_Options/PRODUCT_FORMAT	The final user, according to this download option, will be able to select the User Product format (SAFE, DIMAP or SAFE_COMPACT).			X	From product URI provided by

<sup>3</sup>The "Browse Image" is here referenced as "PreView Image" to be aligned with the ngEO terminology.



**Sentinel-2 Products  
Specification Document**

REF : S2-PDGS-TAS-DI-PSD  
ISSUE : 14.5  
DATE : 14/03/2018  
PAGE : 343 / 510

General_Info (common section)					
Field Name	Description	From Datastrip PDI	From Granule PDI	From Additional Processing	Note
					ngEO containing Download Option flag (for instance: ngEO_DO={ ...,outputFormat:SAFE_COMPACT})
Query_Options/AGGREGATION_FLAG	Flag to select Along-Track Aggregated Granules (L1A/L1B) and Consolidated Tiles (L1C/L2A). (This Field is omitted in case of completeSingleTile = "true")			X	For Level-0, aggregation is always FALSE
Query_Options/SINGLE_TILE	Option selected to generate L1C/L2A Single Tile User Products (This Field is omitted in case of completeSingleTile = "true")			X	
Product_Organisation/Granule_List/@DatastripIdentifier	Product_Organization represents the logical map of the elements (Granules vs Datastrip hierarchy) composing the User Product.  DatastripIdentifier is the attribute identifying the Datastrip linked to the list of the Granules composing the User Product.  In case of User Product including aggregation of Granules (L1A/L1B) or Tiles consolidated (L1C/L2A) this attribute contains two (or more) Datastrip identifiers.	X			
Product_Organisation/Granule_List/Granule/IMAGE_ID (* applicable for PRODUCT_FORMAT SAFE and DIMAP)	Pointers to Granule/Tile image data files (links to the physical image data)		X		





**Sentinel-2 Products  
Specification Document**

REF : S2-PDGS-TAS-DI-PSD  
ISSUE : 14.5  
DATE : 14/03/2018  
PAGE : 344 / 510

General_Info (common section)					
Field Name	Description	From Datastrip PDI	From Granule PDI	From Additional Processing	Note
	attribute: fileFormat (JPEG2000, BINARY)				
Product_Organisation/Granule_List/Granule/IMAGE_FILE (*) applicable for PRODUCT_FORMAT SAFE_COMPACT	This attribute is the relative path of the spectral bands, TCI image data files and, for L2A, AOT, WVP, SCL image data files.		X		
Product image characteristics section (specific for a L0 User Product)					
Product_Image_Characteristics/PHYSICAL_GAINS	Physical gains for each band	X			§ Table 35
Product_Image_Characteristics/REFERENCE_BAND	Reference band	X			§ Table 38
Product_Image_Characteristics/ON_BOARD_COMPRESSION_MODE	<p>Flag to indicate the on board compression mode (by-passed or not).</p> <p>Note: if this flag is set TRUE, the corresponding metadata COMPRESS_MODE at L0 Datastrip PDI level is set TRUE.</p> <p>In case of compression by-passed, the list of active detectors is provided at Datastrip level (ACTIVE_DETECTOR metadata).</p>	X			§ Table 35

Table 79: Level-0 Product\_Metadata\_File - General\_Info Description





## Geometric Info:

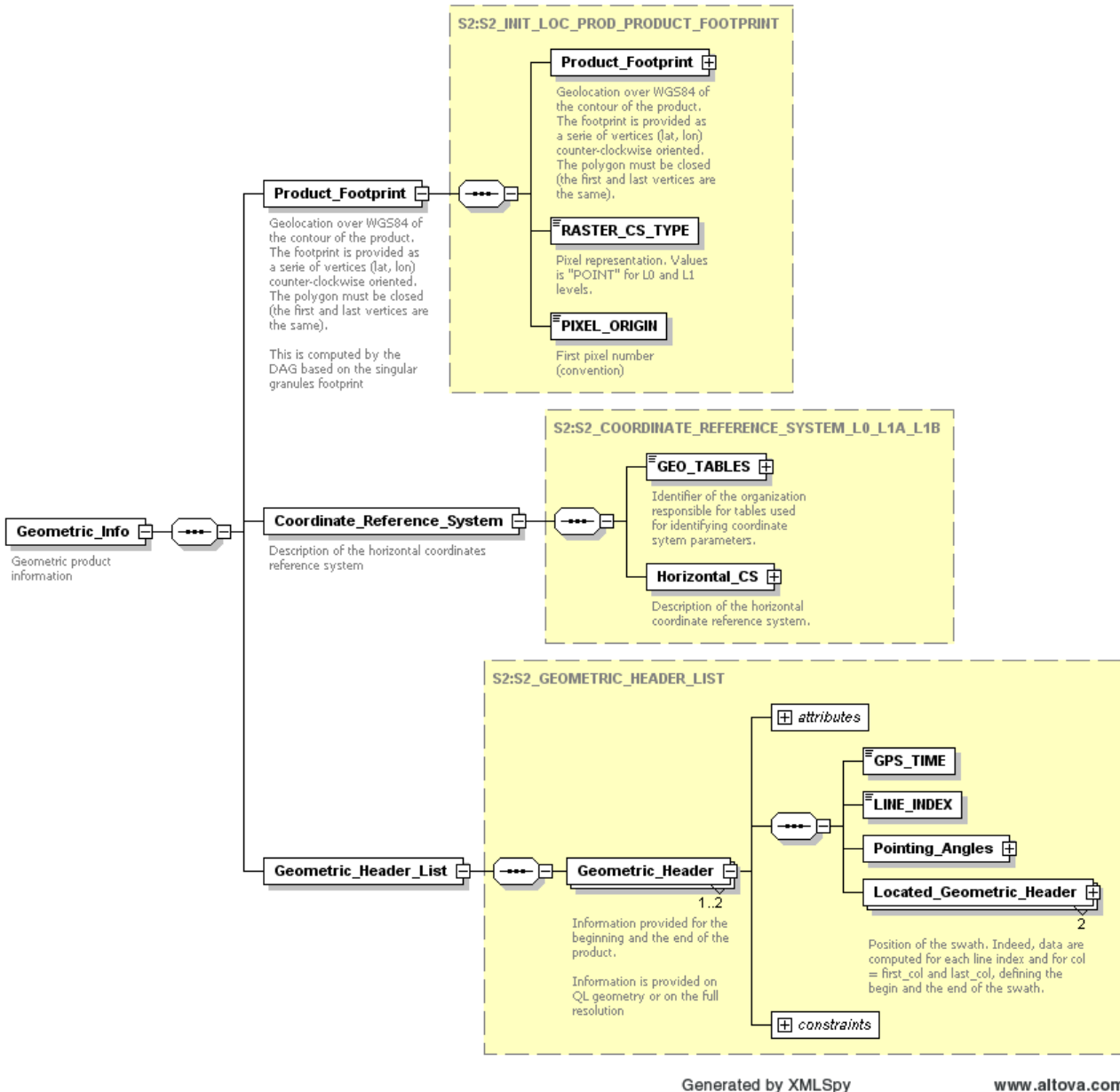

Generated by XMLSpy

www.altova.com

Figure 72: Level-0 Product\_Metadata\_File – Geometric\_Info Diagram



**Sentinel-2 Products  
Specification Document**

REF : S2-PDGS-TAS-DI-PSD  
ISSUE : 14.5  
DATE : 14/03/2018  
PAGE : 346 / 510

<b>Geometric_Info/Product_Footprint</b>				
<b>Field Name</b>	<b>Description</b>	<b>From Level-0 Datastrip PDI</b>	<b>From Additional Processing</b>	<b>Note</b>
Product_Footprint/Global_Footprint/EXT_POS_LIST Product_Footprint/Global_Footprint/INT_POS_LIST	Geolocation over WGS84 of the contour of the product. The footprint is a closed polygon provided as a series of vertices (lat, lon) counter-clockwise oriented.  Global precise footprint of the cut segment (Point list of LAT, LON or X,Y).		X	This is based on the singular Granules footprint
Product_Footprint/Unitary_Footprint_List/Unitary_Footprint /Footprint/EXT_POS_LIST Product_Footprint/Unitary_Footprint_List/Unitary_Footprint /Footprint/INT_POS_LIST	(OPTIONAL) Unitary footprint for each detector, each band of the product.		X	This is not required for the Level-0 product.
Product_Footprint/Product_Footprint/RASTER_CS_TYPE	Pixel representation. Values is "POINT" for L0 and L1 levels.		X	Available at Granulelevel
Product_Footprint/PIXEL_ORIGIN	First pixel number (convention)		X	Available at Granule level
<b>Geometric_Info/Coordinate_Reference_System</b>				
<b>Field Name</b>	<b>Description</b>	<b>From Level-0 Datastrip PDI</b>	<b>From Additional Processing</b>	<b>Note</b>
GEO_TABLES	Identifier of the organization responsible for tables used for identifying coordinate sytem parameters (EPSG).		X	Metadata filled as per description
HORIZONTAL_CS_TYPE	Description of the horizontal coordinates reference system type (PROJECTED   GEOGRAPHIC)		X	Metadata filled as per description
HORIZONTAL_CS_NAME	Description of the horizontal coordinates reference system		X	Metadata filled as per description
HORIZONTAL_CS_CODE	Code of horizontal coordinate reference system. It follows the 'EPSG:xxxx' pattern where xxxx is the unique identification code in		X	Metadata filled as per description





**Sentinel-2 Products  
Specification Document**

REF : S2-PDGS-TAS-DI-PSD  
 ISSUE : 14.5  
 DATE : 14/03/2018  
 PAGE : 347 / 510

the EPSG tables.				
Geometric_Info/Product_Footprint/Geometric_Header_List (provided for the beginning and the end of the product)				
Field Name	Description	From Level-0 Datastrip PDI	From Additional Processing	Note
Geometric_Header/GPS_TIME	A GPS date-time value = TAI format	X		Geometric Header Information are provided for the beginning and the end of the product. § Table 35
Geometric_Header/LINE_INDEX	Integer	X		§ Table 35
Geometric_Header/Pointing_Angles/Satellite_Reference (ROLL, PITCH, YAW)	Pointing angles in satellite reference frame	X		§ Table 35
Geometric_Header/Pointing_Angles/Image_Reference (PSI_X, PSI_Y)	Pointing angles in focal plane referential	X		§ Table 35
Geometric_Header/Located_Geometric_Header/ORIENTATION	Track orientation. Also called "CAPE". The range of the angle is into [0,360°[	X		§ Table 35
Geometric_Header/Located_Geometric_Header/Incidence_Angles (ZENITH_ANGLE, AZIMUTH_ANGLE)	Inceidence angles	X		§ Table 35
Geometric_Header/Located_Geometric_Header/Solar_Angles (ZENITH_ANGLE, AZIMUTH_ANGLE)	Solar angles	X		§ Table 35
Geometric_Header/Located_Geometric_Header/Pixel_Size (ALONG_TRACK, ACROSS_TRACK)	Full resolution pixel sizes along and across track in meters	X		§ Table 35

Table 80: Level-0 Product\_Metadata\_File - Geometric\_Info Description



Auxiliary Data Info:

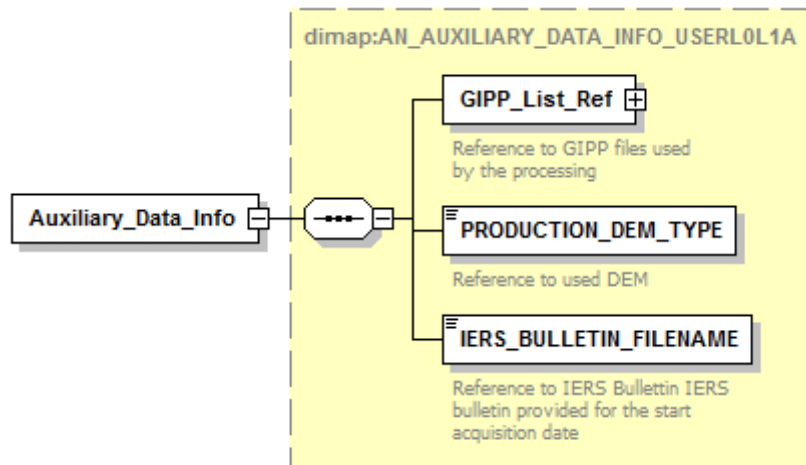

Generated by XMLSpy

www.altova.com

Figure 73 : Level-0 Product\_Metadata\_File – Auxiliary\_Data\_Info Diagram



**Sentinel-2 Products  
Specification Document**

REF : S2-PDGS-TAS-DI-PSD  
 ISSUE : 14.5  
 DATE : 14/03/2018  
 PAGE : 349 / 510

Auxiliary_Data_Info				
Field Name	Description	From Level-0 Datastrip PDI	From Additional Processing	Note
GIPP_List_Ref/GIPP_FILENAME	Reference to the GIPP files used by the processing chain.  These files could be in the product (AUX_DATA folder) according to a specific download option.	X		§ Table 38
PRODUCTION_DEM_TYPE	DEM type used by the production process (GLOBE or SRTM)	X		§ Table 38
IERS_BULLETIN_FILENAME	IERS bulletin filename.  This files could be in the product (AUX_DATA folder) according to a specific download option.		X	§ Table 38

Table 81: Level-0 Product\_Metadata\_File – Auxiliary\_Data\_Info Description



## Quality Indicators Info:

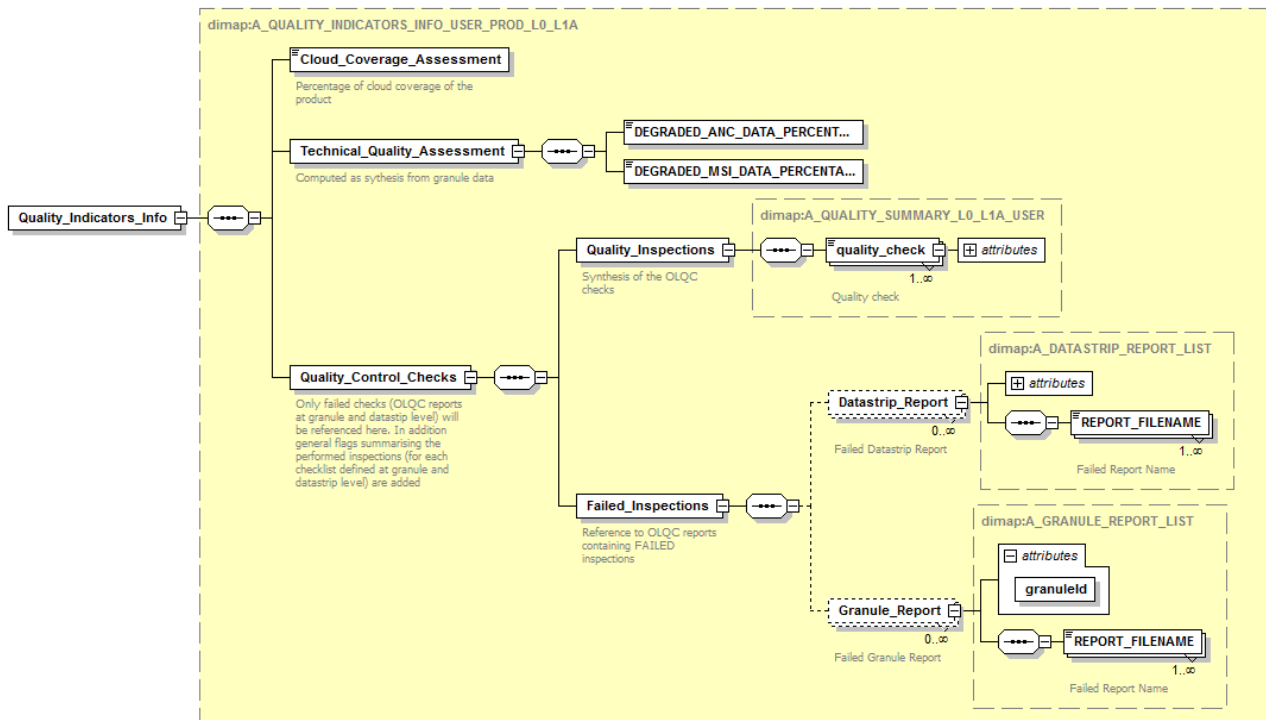

Generated by XMLSpy

www.altova.com

Figure 74 : Level-0\_Product\_Metadata\_File – Quality\_Indicators\_Info Diagram



## Sentinel-2 Products Specification Document

REF : S2-PDGS-TAS-DI-PSD  
 ISSUE : 14.5  
 DATE : 14/03/2018  
 PAGE : 351 / 510

Quality Indicators Info					
Field Name	Description	From Level-0 Datastrip PDI	From Level-0 Granule PDI	Additional Processing	Note
CLOUD_COVERAGE_ASSESSMENT	Percentage of cloud coverage of the product for each area covered by a reference band		X	X	Based on CLOUDY_PIXEL_PERCENTAGE computed for each Granules composing the product:  AVG(CLOUDY_PIXEL_PERCENTAGE)%
Quality Indicators Info/Technical Quality Assessment					
Field Name	Description	From Level-0 Datastrip PDI	From Level-0 Granule PDI	From Additional Processing	Note
DEGRADED_ANC_DATA_PERCENTAGE	Percentage of degraded ancillary data over the product.	X		X	Based on "degradationPercentage" values computed for each Datastrip:  AVG(degradationPercentage)%
DEGRADED_MSI_DATA_PERCENTAGE	Percentage of degraded MSI data over the product.		X	X	Based on DEGRADED_MSI_DATA_PERCENTAGE computed for each Granule:  AVG(DEGRADED_MSI_DATA_PERCENTAGE)%
Quality Indicators Info/Quality Control Checks/Quality Inspections					
Field Name	Description	From Level-0 Datastrip PDI	From Level-0 Granule PDI	From Additional Processing	Note





**Sentinel-2 Products  
Specification Document**

REF : S2-PDGS-TAS-DI-PSD  
 ISSUE : 14.5  
 DATE : 14/03/2018  
 PAGE : 352 / 510

quality_check	Synthesis of the OLQC checks performed at: Granule level and or Datastrip level.  Those checks are grouped in the OLQC reports and provided in the Granules/QI_DATA and Datastrip/QI_DATA folders.	X	X	X	The field is based on the OLQC reports contained in the Granules/QI_DATA and Datastrips/QI_DATA  The OLQC reports are in <i>globalStatus</i> FAILED if at least one report at Datastrip level and/or s at Granules level is with <i>globalStuatus</i> FAILED.
quality_check/@check_type	Type of the check				Cf. Table 3-17, Table 3-24
<b>Quality Indicators Info/ Quality Control Checks/Failed Inspections</b>					
Field Name	Description	From Level-0 Datastrip PDI		From Additional Processing	Note
Datastrip_Report/REPORT_FILENAME	Reference (through the filename) to failed Datastrip reports (i.e. refers to OLQC reports with <i>globalStatus</i> FAILED).	X		X	REPORT_FILENAME list corresponds with the list of the FAILED Datastrip reports.
Granule_Report/REPORT_FILENAME	Reference (through the filename) to failed Granule reports(i.e. refers to OLQC reports with <i>globalStatus</i> FAILED).		X	X	REPORT_FILENAME list corresponds with the list of the FAILED Granule reports.

Table 82: Level-0 Product\_Metadata\_File – Quality\_Indicators\_Info Description



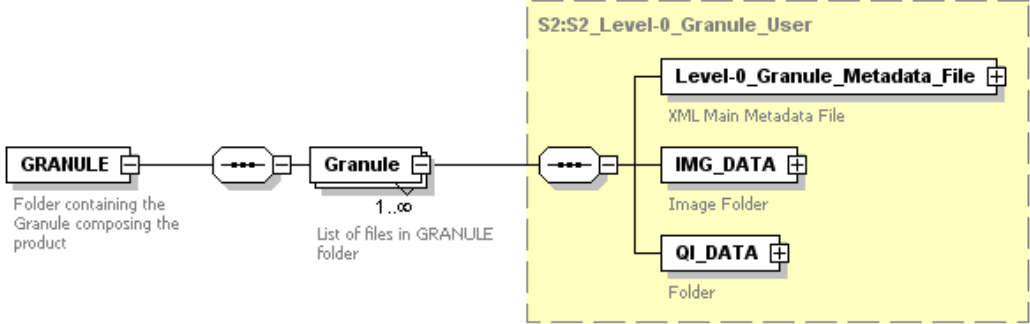

#### 4.6.7.2 GRANULE

<p>diagram</p>	 <p align="center">Generated by XMLSpy <a href="http://www.altova.com">www.altova.com</a></p>
<p>annotation</p>	<p>GRANULE folder is a “folder of folders” each one corresponding to the Granules composing the product and identified by proper PDI_ID (Granule_ID). The structure of each Granule included in the product is the same of the Level-0 Granule PDI described in the section 3.5.8 taking into account that:</p> <ol style="list-style-type: none"> <li>1. the Granules metadata are copied in the User Product as they are except for the <i>metadataLevel</i> attribute (Brief/Standard/Expertise) always set as empty string (cf. section 4.6.6),</li> <li>2. the XML <i>Level-0_Granule_Metadata_File</i> is validated using the <i>S2_PDI_Level-0_Granule_Metadata.xsd</i> schema annexed to the document,</li> <li>3. the <i>Inventory_Metadata.xml</i>, <i>manifest.safe</i> and <i>rep_info</i> are removed when the Granule PDI is included in the User Product (cf. section 3.5.8).</li> </ol>

#### 4.6.7.3 DATASTRIP

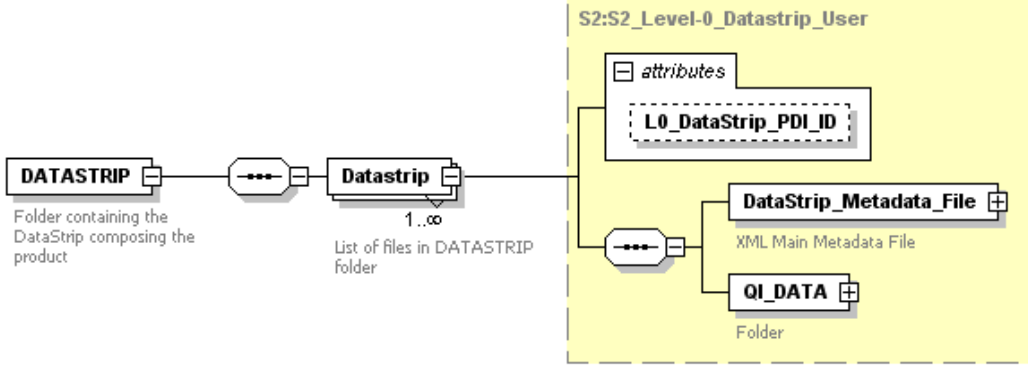
<p>diagram</p>	 <p align="center">Generated by XMLSpy <span style="float: right;">www.altova.com</span></p>
<p>annotation</p>	<p>DATASTRIP folder is a “folder of folders” each one corresponding to the Datastrip composing the product and identified by proper PDI_ID (Datastrip_ID).        The structure of each Datastrip included in the product is the same of the Level-0 Datastrip PDI described in the section 3.6.3 taking into account that:</p> <ol style="list-style-type: none"> <li>1. the Datastrips metadata are copied in the User Product as they are except for the <i>metadataLevel</i> attribute (Brief/Standard/Expertise) always set as empty string (cf. section 4.6.6),</li> <li>2. the XML <i>Datastrip_Metadata_File</i> is validated using the <i>S2_PDI_Level-0_Datastrip_Metadata.xsd</i> schema annexed to the document,</li> <li>3. <i>Inventory_Metadata.xml</i>, <i>manifest.safe</i>, <i>ANC_DATA</i> and <i>rep_info</i> are removed when the Datastrip PDI is included in the User Product (cf. section 3.6.3).</li> </ol> <p>Note: Since the <i>ANC_DATA</i> folder inside the L0 Datastrip PDI is removed during the L0 User Product generation, the metadata <i>ANC_DATA_REF</i> inside the L0 User Product (defined at Datastrip level) refers to the mandatory folder <i>ANC_DATA</i> contained in the L0 User Product.</p>

#### 4.6.7.4 AUX\_DATA

diagram	<div style="border: 1px solid black; padding: 5px; margin-bottom: 10px;"> <b>AUX_DATA</b> </div> <p>Folder containing (if requested by the user, download option) all Auxiliary Data used for the processing</p> <p align="center">Generated by XMLSpy <span style="float: right;">www.altova.com</span></p>
annotation	<p>All Auxiliary Data used for Level-0 processing are referenced through the Product_Metadata_File. GIPP files and IERS Bulletin file can be provided if requested by the user (download option). DEM is not provided itself inside the product but only as a reference to the data used.</p>

#### 4.6.7.5 ANC\_DATA

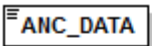
diagram	<div style="border: 1px solid black; padding: 5px; margin-bottom: 10px;">  <b>ANC_DATA</b> </div> <p>Folder containing SAD raw data. The latest SAD related to the downlink time will be embedded in the L0 User Product</p> <p align="center">Generated by XMLSpy <span style="float: right;">www.altova.com</span></p>
annotation	<p>This folder contains different SAD files, one for each SAD packet type (SID, cf. Table 11). In order to have the maximum coverage of the raw SAD in the L0 User Product, the latest SAD related to the downlink time will be embedded in the product.</p>

#### 4.6.7.6 Browse\_Image

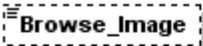
diagram	<div style="border: 1px dashed black; padding: 5px; margin-bottom: 10px;">  <b>Browse_Image</b> </div> <p>Browse Image File (PNG)</p> <p align="center">Generated by XMLSpy <span style="float: right;">www.altova.com</span></p>
annotation	<p>Browse Image file in PNG format. The Browse Image is included in the User Product if required by the user (download option). This Browse Image is based on the PVI extracted from the Level-1C Tile PDI (JPEG2000 low resolution extraction, 3 visible-bands in ground geometry at 320m resolution, RGB). The final geometric representation of the Browse Image is defined by the user according to its region of interest (either geographic or cartographic representation).</p>

#### 4.6.8 User Product Level-0 SAFE Manifest synoptic table

The User Product contains only one main *manifest.safe* file. The *manifest.safe* files related to each Granules/Datastrips composing the product are available at PDI level but they are not included in the User Product, all lower level PDI are removed.

This chapter provides a detailed description of the content of the SAFE Manifest for the Level-0 User product.

Since the User Product metadata refers to the contained Granules and Datastrips, the structure of the Manifest is based on the Level-0 Manifests provided for Granules and Datastrip (cf. sections 3.5.9 and 3.6.4).

The SAFE Manifest file is compliant to the SAFE specification (cf. [SAFE-SPEC]) and is composed by three main sections (Metadata, Information Package Map and Data Objects).

With reference to the three mentioned sections the chapter provides, as a guideline to the generation process of the SAFE Manifest file, the following elements:

- Table 31 describing the content and structure of the Information Package Map section; same consideration apply as in section 3.5.9;
- for the Metadata Section, a table that lists the fields (tags) composing the section, providing, for each field:
  - the field name in the SAFE Manifest file (column “SAFE Manifest”, divided into column “Metadata name”, containing the name of the Metadata section of the manifest to which the field belongs, and “Name of tag or attribute” containing the actual tag name or attribute name (for sake of clarity, attributes are written in bold characters))
  - the name of the corresponding tag (if available, else N.A.) of the S2\_User\_Product\_Level-0\_Metadata.xsd;
  - a brief textual description of the field;
  - the data type of the field (e.g. string, string enum, integer, double, xs:dateTime etc.);
  - the occurrence of the field (min/man occurrence e.g. 0..1); a minimum occurrence of 1 means that the field is mandatory;
  - the allowed range of values of the field.
- Table 33 describing the content and structure of the Data Objects section; consider that this section contains a reference to each file (Data files and Metadata files) composing the Level-0 User Product (with the exception of the Manifest file itself); this includes:
  - the XML Main Metadata file;
  - the INSPIRE Metadata.XML file;
  - the Auxiliary Data files (IERS Bulletin, GIPPs) required by the processing and included in the product, in the AUX\_DATA folder;
  - the Ancillary Data files needed by processing and included in the product, in the ANC\_DATA folder;
  - the Preview Image, used for image data browsing and selection purposes;

- all files included in the "GRANULE" folder, representing the Granules composing the User Product;
- all files included in the "DATASTRIP" folder, representing the Datastrips linked to the Granules composing the User Product.

A practical example of Manifest file for the Level-0 User Product is provided as annexed to this document (S2-PDGS-TAS-DI-PSD-V14\_SAFE.zip).

SAFE Manifest		Corresponding metadata in the S2_User_Product_Level-0_Metadata.xsd	Description	Data Type	Occurrence	Allowed range of values
Metadata name	Name of tag or attribute (in bold)	Tag name				
platform						
	nssdcIdentifier	N.A.	Unique identifier of the platform, defined by the World Data center for Satellite Information (WDC-SI)		1	WDC is discontinued; this tag is set to a default value 0000-0000
	familyName	Level-0_User_Product->General_Info->Datatake->SPACECRAFT_NAME	The mission name of the platform	string enum	0..1	Sentinel
	number	Level-0_User_Product->General_Info->Datatake->SPACECRAFT_NAME	Sequence identifier of the platform among the mission	string enum	0..1	2A, 2B, 2C
	instrument->familyName	N.A.	The instrument name used for acquiring the product data	string enum	0..1	Multi-Spectral Instrument
	instrument-> <b>abbreviation</b>	N.A.	Abbreviation of the instrument name	string enum	0..1	MSI
	instrument->mode	N.A.	The mode of the instrument	string enum	0..1	Nominal_Observation Dark_Signal_Calibration Extended_Observation Absolute_Radiometry_Calibration Vicarious_Calibration Raw_Measu

SAFE Manifest		Corresponding metadata in the S2_User_Product_Level-0_Metadata.xsd	Description	Data Type	Occurrence	Allowed range of values
Metadata name	Name of tag or attribute (in bold)	Tag name				
						rement Test_Mode
	instrument->mode-> <b>identifier</b>	Level-0_User_Product->Product_Metadata_File->General_Info->Datatake->DATATAKE_TYPE	The identifier of the instrument mode	string enum	1	INS-NOBS INS-EOBS INS-DASC INS-ABSR INS-VIC INS-RAW INS-TST
processing			Textual description of the history of processings that lead to the current product and of all the relevant resources involved in the processing (facilities, software, applicable documents etc)		1	
	<b>name</b>		Name of the L0 Processing	string	0..1	L0 Processing of Raw Data
	<b>start</b>	Level-0_User_Product->General_Info->GENERATION_TIME	Processing start date (UTC)	xs:dateTime	0..1	
	facility	N.A.	Description of Processing Centre		0..*	
	facility-> <b>name</b>	N.A.	Extended name of Origin Centre	string	1	
	facility-> <b>organization</b>	N.A.	Organization to which the Origin center belongs	string	0..1	

SAFE Manifest		Corresponding metadata in the S2_User_Product_Level-0_Metadata.xsd	Description	Data Type	Occurrence	Allowed range of values
Metadata name	Name of tag or attribute (in bold)	Tag name				
	facility-> <b>site</b>	Level-0_User_Product->GRANULE->General_Info->GRANULE_ID (substring <Site Centre>)	Acronym of the Processing center	string enum	0..1	SGS_ MPS_ MTI_ EPA_ MPC_ UPA_ XXXX EDRS zzzL (zzz = first three characters of the LGS location)
	facility-> <b>country</b>	N.A.	Country where Origin Centre is located	string	0..1	
	facility->software	N.A.	Description of software component used for Processing		0..*	
	facility->software-> <b>name</b>	N.A.	Name of the software component	string	1	
	facility->software-> <b>version</b>	N.A.	Version of the software component	string	0..1	
	facility->resource		List of auxiliary data files used by the processors to support radiometric and geometric correction (GIPP, DEM, GRI, IERS Bulletin etc.) and of SAD Raw Data file containing the satellite ancillary telemetry; these files are provided with the		0..*	



SAFE Manifest		Corresponding metadata in the S2_User_Product_Level-0_Metadata.xsd	Description	Data Type	Occurrence	Allowed range of values
Metadata name	Name of tag or attribute (in bold)	Tag name				
			product.			
	facility->resource-> <b>name</b>	Level-0_User_Product->DATASTRIP->Satellite_Ancillary_Data_Info->ANC_DATA_REF (reference to the folder containing the SAD Raw Data files)  Level-0_User_Product->DATASTRIP->Auxiliary_Data_Info->IERS_Bulletin  Level-0_User_Product->DATASTRIP->Auxiliary_Data_Info->GIPP_List->GIPP_FILENAME  Level-0_User_Product->DATASTRIP->Auxiliary_Data_Info- DEM_FILENAME	Name of the auxiliary or ancillary files/folders needed for the Processing	string	1	
	facility->resource-> <b>role</b>	N.A.	Role of the resource	string	1	Auxiliary data, Ancillary data
acquisitionPeriod					1	
	acquisitionPeriod ->startTime	Level-0_User_Product->General_Info->Datatake->DATATAKE_SENSING_START	Reference time of acquisition of the product	xs:dateTime	1	
measurementFrameSet					1	
	footPrint	Derived from Level-0_User_Product->Geometric_Info->Product_Footprint	Product footprint (namely imaged landscape corresponding to the	string (gml:linearRingType namely blank separated list of	0..1	



**Sentinel-2 Products  
Specification Document**

REF : S2-PDGS-TAS-DI-PSD  
 ISSUE : 14.5  
 DATE : 14/03/2018  
 PAGE : 362 / 510

SAFE Manifest		Corresponding metadata in the S2_User_Product_Level-0_Metadata.xsd	Description	Data Type	Occurrence	Allowed range of values
Metadata name	Name of tag or attribute (in bold)	Tag name				
			whole product)	comma-separated long/lat coordinates of footprint closed polygon with last vertex equal to first) <sup>4</sup>		
measurementOrbitReference						
	orbitNumber	Level-0_User_Product->General_Info->Datatake->DatatakeIdentifier (substring <AbsoluteOrbitNumber>)	Absolute orbit number		0..1	> 0
	orbitNumber->type	N.A.	Absolute orbit number type (possible values "start" or "stop"). Set to "start" since the absolute orbit number refers to the first line of the first Granule of the User Product		0..1	start
	orbitNumber-> <b>groundTrackDirection</b>	Level-0_User_Product->General_Info->Datatake->SENSING_ORBIT_DIRECTION	Direction of the ground track of the Sentinel-2 platform at the time corresponding to orbitNumber->type (start		0..1	ascending, descending

<sup>4</sup>Note that the mentioned "gml" namespace represents the standard for geolocation in SAFE format and is not related to DIMAP type A\_GML\_POLYGON\_3D; in order to convert lat/long coordinates between the DIMAP type A\_GML\_POLYGON\_3D and the types gml:pointType and gml:linearRing in the tags <center> or <footprint>, the DIMAP lat/long coordinates should be simply moved into the corresponding tag of SAFE Manifest, properly formatted and the EPSG code in which these coordinates are expressed should be moved into the attribute srsName.



SAFE Manifest		Corresponding metadata in the S2_User_Product_Level-0_Metadata.xsd	Description	Data Type	Occurrence	Allowed range of values
Metadata name	Name of tag or attribute (in bold)	Tag name				
			or stop)			
	relativeOrbitNumber	Level-0_User_Product->General_Info->Datatake->SENSING_ORBIT_NUMBER	Relative orbit number (within the cycle)		0..1	1 to 143
	relativeOrbitNumber-> <b>type</b>	N.A.	Relative orbit number type (possible values "start" or "stop"). Set to "start" since the absolute orbit number refers to the first line of the Datastrip		0..1	start
metadataComponents		Level-0_User_Product->DATASTRIP->Satellite_Ancillary_Data_Info->ANC_DATA_REF (reference to the folder containing the SAD Raw Data files)  Level-0_User_Product->DATASTRIP->Auxiliary_Data_Info->IERS_Bulletin  Level-0_User_Product->DATASTRIP->Auxiliary_Data_Info->GIPP_List->GIPP_FILENAME	A reference to all ancillary/auxiliary Metadata files/folders included in the product (e.g. the XML Metadata file, the INSPIRE Metadata file, the Ancillary Data files, the Auxiliary Data files)		1..*	
metadataComponentSchemas		N.A.	A reference to the Schemas used to validate the Metadata files included in the product (e.g. the XML Metadata file Schema)		0..1	

Table 83 - Content of Metadata section for Level-0 User Product SAFE Manifest



**Sentinel-2 Products  
Specification Document**

REF : S2-PDGS-TAS-DI-PSD  
ISSUE : 14.5  
DATE : 14/03/2018  
PAGE : 364 / 510



## 4.7 Level-1A User Product specification

### 4.7.1 Introduction

The Level-1A User Product is obtained by decompressing image data and developing a geometric model to locate any pixel in the image.

The following table introduces the input data of Level-1A processing:

Input of Level-1A processing	Description
Metadata	Metadata from Level-0 product
Image Data	Level-0 data (Granules)
Auxiliary Data	GIPP: Parameters from Level-0 complemented by radiometric and geometric processing parameters. DEM: only the reference to the data used is provided.
Quality Indicator Data	Quality indicators from Level-0

Table 84: Input for Level-1A processing

This level corresponds to the systematic processing steps that must be applied before any further processing. It includes:

- decompression of the image data,
- geometric model computation : geolocation information, coarse interband / interdetector registration,
- SWIR pixels re-arrangement.

As requiring only a fast processing, this 'Raw Level' product can be used to allow a quick display of the detectors (sub-swaths) in full resolution. The sub swath can be displayed using standard commercial image processing software.

Note that one Level-1A product:

- refers always to one Datatake;
- refer to one or several Datastrip from the same Datatake;
- may cover the full Datatake or an extract of the Datatake.

In the case of an extract, image data is provided only to cover the selected area.

The following figure gives an overview of the Level-1A User Product physical format. The yellow boxes correspond to folders and the white ones to files:

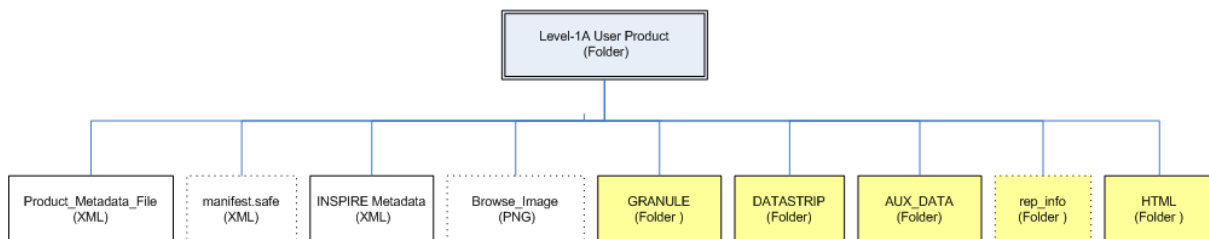

Figure 75: Level-1A User Product Structure

The Level-1A User Product consists of:

1. **Product\_Metadata\_File**: mandatory XML main metadata file.
2. **manifest.safe**: SAFE metadata file (optional). It is included in the product only if the user requests the SAFE as output format (download option).
3. **GRANULE**: folder containing all Granules composing the product (Image Data). The Image Data extent (raster files) correspond to a set of Granules and can covers up to *12 detectors \* 13 bands* of the orbit in full resolution. A sub-set of the 13 bands can be provided (download option).
4. **DATASTRIP**: folder containing the Datastrip composing the product linked to the selected Granules.
5. **AUX\_DATA**: folder containing, if requested by the user (download option), the GIPP files and IERS Bulletins used for the Level-1A User Product production. All Level-1A auxiliary data are referenced in the product metadata file.
6. **rep\_info**: folder containing the XSD schema provided inside the product. This folder is optional. It is included in the User Product if the user selects the SAFE format as output format (download option).
7. **Browse\_Image**: PNG file consisting of an image limited to 3 visible-bands in ground geometry at 320m resolution. This file, provided if requested by the user (download option), gives an overview of the product (sub-sampled) mainly for image data browsing and selection purposes.
8. **INSPIRE**: XML INSPIRE metadata file (cf. Annex B).
9. **HTML**: folder containing an HTML product presentation file (UserProduct\_index.html) and the corresponding stylesheet (UserProduct\_index.xsl).

#### 4.7.2 Image Data

The Level-1A image data correspond to a collection of elementary Granules. Each Granule corresponds to one detector of one on board scene and therefore consists of N consecutive lines of one detector of a band, where N depends on the band Spatial Sampling Distance (SSD).

SSD	Number of bands	N : Number of full resolution lines per detector and per band in one Granule
10 m	4	2304
20 m	6	1152
60 m	3	384

Table 85: Number of lines in one Granule

The image data extent correspond to a set of “Granules” and can covers up to 12 detectors \* 13 bands of the orbit in full resolution. A sub-set of the 13 bands can be provided.

Each Level-1A Granule is identified in a unique way, using a unique identifier PDI\_ID defined in the section 3.7.1.

##### 4.7.2.1 Image Data Encoding and Files

Each image pixel value is encoded on 12 useful bits (as on-board).

The image data are provided as separated files for each spectral band (i.e. in total of 13 GML/JPEG2000 files per Granule).

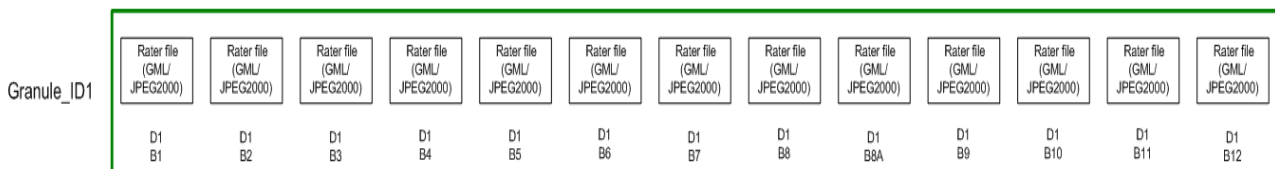

Figure 76 : Example of Level-1A Granule (image data) corresponding to Detector 1

In order to facilitate the product handling at the user base, it will be possible to provide the raster files according to two delivery options:

- Either one file per spectral band and per Granule. For instance, the user can request on a selection of six Granules, the six raster files corresponding to the spectral band B3 (six separated GML/JPEG2000).
- Either a file per spectral band corresponding to the concatenation of *Granules along-track* also called *aggregation of Granules*. For instance, the user can request on an aggregation of six Granules, the raster file corresponding to the spectral band B3 (one single GML/JPEG2000) (§ 4.7.8).

#### 4.7.3 Ancillary Data

The raw Satellite Ancillary Data are not embedded in the Level-1A User Product.



#### 4.7.4 Auxiliary Data

All Auxiliary Data used for Level-1A processing are referenced in the product metadata file:

- IERS bulletin file,
- Ground Image Processing Parameters (GIPPs) files (cf. Annex D),
- Reference to the used DEM.

For each auxiliary data a specific PDI is provided (cf. section 3.1) i.e. all Level-1A auxiliary data will be stored in archive and referenced by a unique identifier (PDI\_ID equal to the PDI filename).

The final user, according to a specific download option, will be able to include in the Level-1A User Product, the IERS bulletin auxiliary file and/or the used GIPP files. DEM is never provided within the product but only as a reference to the data used.

#### 4.7.5 Quality Indicators

The *Product Level Quality Indicators* are provided at product level and referenced through the product metadata file

The *Granule Level Quality Indicators* are provided at Granule level and referenced through the Granule metadata file.

The *Pixel Level Quality Indicators* are provided at Granule level through dedicated quality mask files pointed through the Granule level metadata file.

#### 4.7.6 Metadata

The following table shows the groups of metadata provided inside a Level-1A User Product:

Level-1A User Product Metadata	
<b>Product Level Metadata</b>	All product level metadata, specific for the User level, are consolidated/computed because not present at Granule and Datastrip level.
<b>Granule Level Metadata (Brief/Standard/Expertise)</b>	All Brief/Standard/Expertise metadata (download option, cf. section 4.4) defined at Granule level are copied from the input Granules to the User Product.
<b>DATASTRIP Level Metadata (Brief/Standard/Expertise)</b>	All Brief/Standard/Expertise metadata (download option, cf. section 4.4) defined at Datastrip level are copied from the input Datastrips to the User Product;

Table 86: Level-1A Product Metadata

As mentioned in the section 2.10, the User Product metadata (all) are not provided with a *metadataLevel* attribute (Brief/Standard/Expertise) unlike what happens for all Granule and Datastrip metadata.

During the User Product assembling, this attribute is used to select by filtering, according to a download option, the set of metadata that must be included in the User Product.

For these filtered fields, the *metadataLevel* attribute is not written in the User Product's metadata.

Note that an User Product for an expert user (Expertise download option) will contain all level of metadata (Brief/Standard/Expertise). An User Product for a user with "Standard" or "Brief" permission will contain only Brief/Standard or Brief metadata.

In addition to the metadata in the table above, the User Product contains the *manifest.safe* metadata (when the User Product is SAFE format) and the INSPIRE metadata.

The Level-1A Product Metadata are detailed in the section 4.7.7.1.

#### 4.7.7 User Product Level-1A Structure

*S2\_User\_Product\_Level-1A\_Structure.xsd* schema annexed to the document and shown in the following diagram, represents the structure of a S2 Level-1A User Product. This schema is provided for information only as It is actually not expected to be used for the validation of a XML file. The diagram reflects exactly the structure shown in the Figure 65.

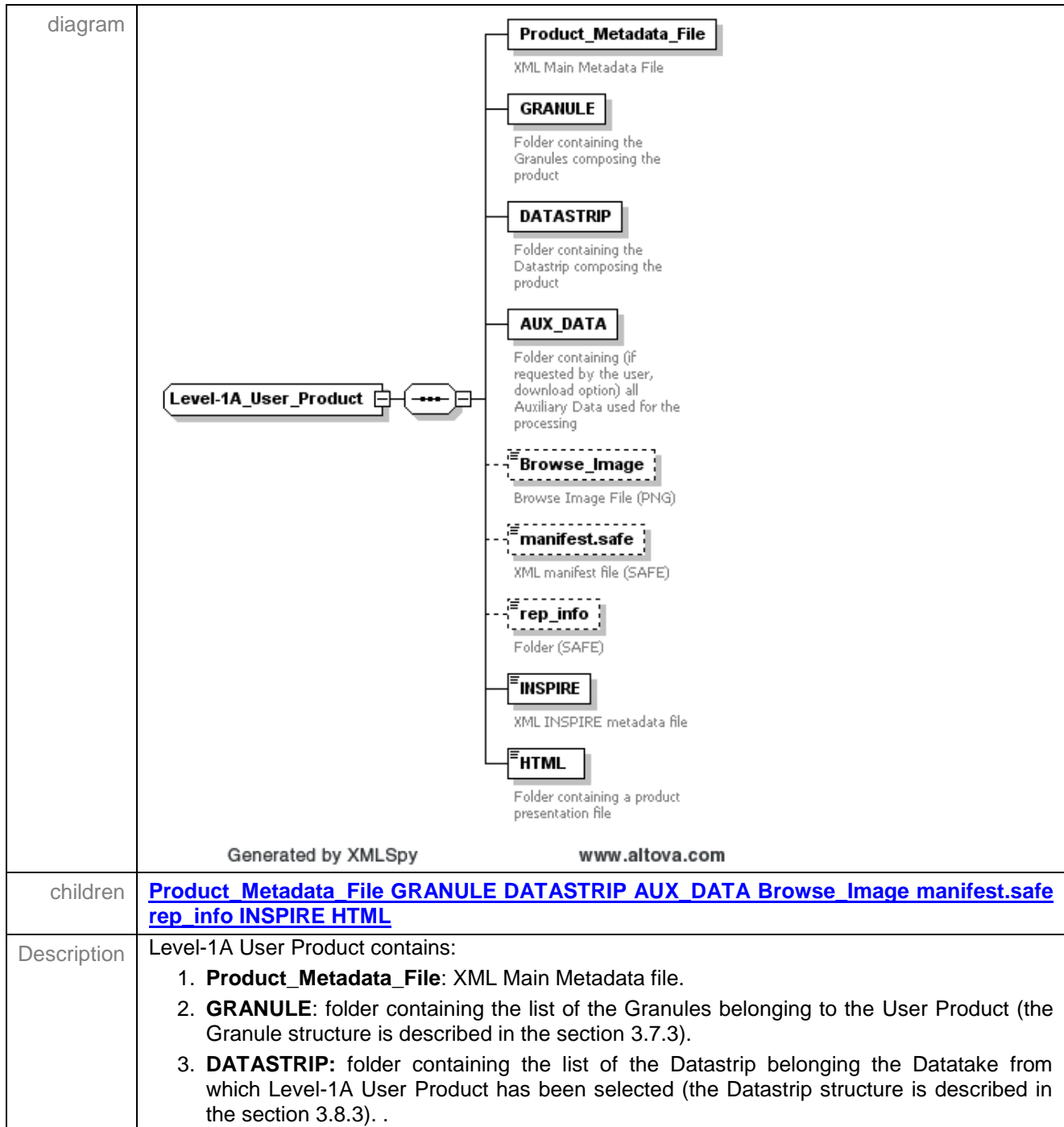

4. **AUX\_DATA**: folder containing all Auxiliary Data used for Level-1A processing (optional, the aux data are included in the product if selected according to a specific download option).
5. **Browse\_Image**: PNG file for image data browsing and selection purposes.
6. **manifest.safe**: XML SAFE Manifest file
7. **rep\_info**: optional folder containing the XSD schema
8. **INSPIRE.xml**: XML INSPIRE metadata file
9. **HTML**: folder containing an HTML product presentation file and the corresponding stylesheet.

#### 4.7.7.1 Product\_Metadata\_File Schema

Product\_Metadata\_File is the XML metadata file provided inside the S2 Level-1A User Product. The XSD schema annexed to this document and used to validate it is *S2\_User\_Product\_Level-1A\_Metadata.xsd*.

A detailed description of the schema is given here but for specific details regarding each metadata (e.g. type, default value, fixed value, enumerations, occurrences, etc...) refers to the XSD file.

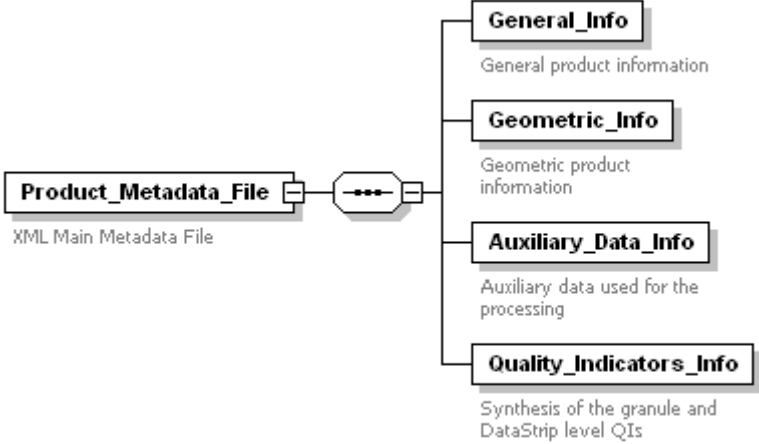
<p>diagram</p>	 <p align="center">Generated by XMLSpy <span style="float:right">www.altova.com</span></p>
<p>children</p>	<p><a href="#">General Info</a> <a href="#">Geometric Info</a> <a href="#">Auxiliary Data Info</a> <a href="#">Quality Indicators Info</a></p>
<p>Description</p>	<p>The Product_Metadata_File describes the product data items. It is presented to the user as a structured container of information. Product_Metadata_File is an XML file containing:</p> <ol style="list-style-type: none"> <li>1. <b>General_Info</b>: provides general product information.</li> <li>2. <b>Geometric_Info</b>: describing the geolocation over WGS84 of the contour of the product.</li> <li>3. <b>Auxiliary_Data_Info</b>: Links to the AUX_DATA items.</li> <li>4. <b>Quality_Indicators_Info</b>: Synthesis of the Granule and Datastrip level QIs.</li> </ol>

The following figures and tables give a complete description of the User Product metadata.

General Info:

In addition to the general information, common to all processing level (cf. Table 79) , the specific (general) metadata provided with a Level-1A User Product, are described hereafter.

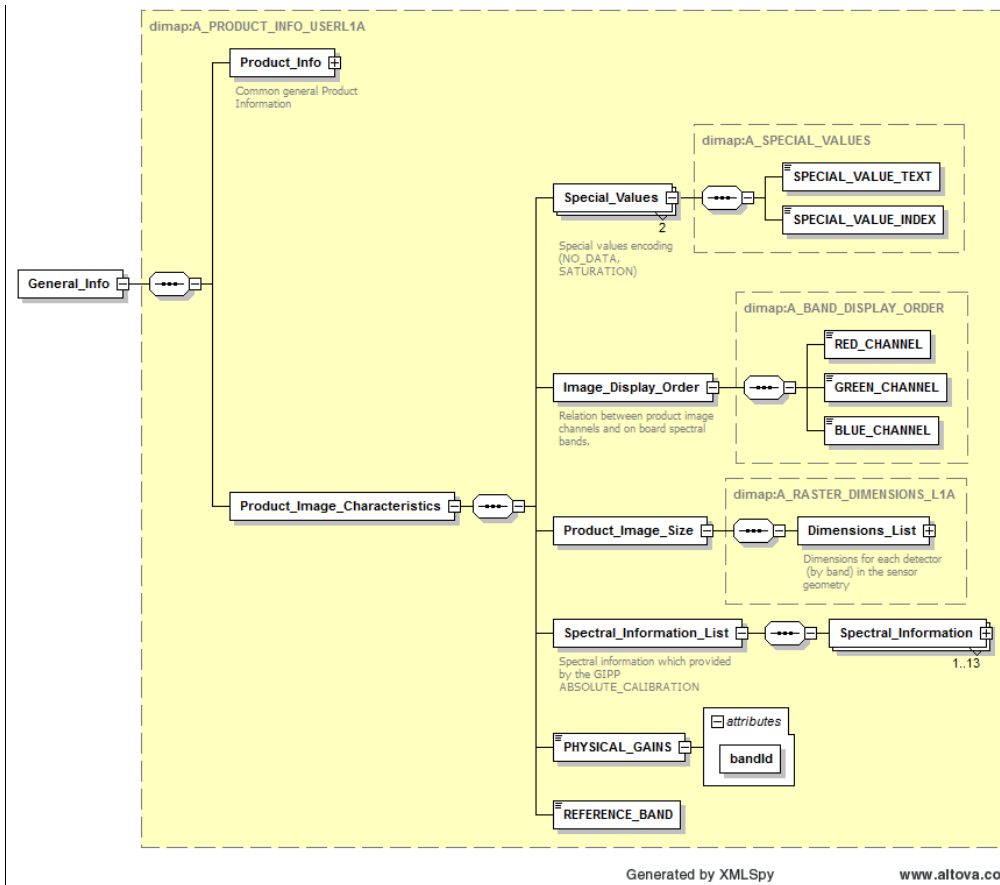

Figure 77 : Level-1A Product\_Metadata\_File - General\_Info Diagram

**General\_Info**



Field Name	Description	Note
Product_Info	This group of metadata is described in the Table 79.	Table 79
Product_Image_Characteristics/Special_Values/SPECIAL_VALUE_T XT Product_Image_Characteristics/Special_Values/SPECIAL_VALUE_I ND EX	Special values encoding (e.g. NODATA, SATURATION)	Based on Radiometric_Info (PIXELS_NO_DATA_PROC and SATURATED_PIXELS_PROC ) available at Datastrip level (cf. Table 45 ).
Product_Image_Characteristics/Image_Display_Order/RED_CHANNE L Product_Image_Characteristics/Image_Display_Order/GREEN_CHAN NEL Product_Image_Characteristics/Image_Display_Order/BLUE_CHANNE L	Spectral bands (Relation between product image channels and on board spectral bands)	Information available at Datastrip level (cf. Table 45).
Product_Image_Characteristics/Product_Image_SizeDimension_List/Di mensions/ Detector_Dimensions/NROWS Product_Image_Characteristics/Product_Image_SizeDimension_List/Di mensions/ Detector_Dimensions/NCOLS	Product Image size (by band x detector)	Based on Granule dimensions
Product_Image_Characteristics/Spectral_Information_List/Spectral_I nformation/RESOLUTION Product_Image_Characteristics/Spectral_Information_List/Spectral_I nformation/Wavelength/MIN Product_Image_Characteristics/Spectral_Information_List/Spectral_I nformation/ Wavelength/MAX Product_Image_Characteristics/Spectral_Information_List/Spectral_I nformation/ Wavelength/CENTRAL Product_Image_Characteristics/Spectral_Information_List/Spectral_I nformation/Spectral_Response/STEP Product_Image_Characteristics/Spectral_Information_List/Spectral_I nformation/Spectral_Response/VALUES	Spectral filter information provided by the GIPP ABSOLUTE_CALIBRATION	Information available at Datastrip level (cf. Table 45).
Product_Image_Characteristics/PHYSICAL_GAINS	Physical Gain for each band	
Product_Image_Characteristics/REFERENCE_BAND	Reference Band used in the processing	

Table 87: Level-1A Product\_Metadata\_File - General\_Info Description



**Sentinel-2 Products  
Specification Document**

REF : S2-PDGS-TAS-DI-PSD  
ISSUE : 14.5  
DATE : 14/03/2018  
PAGE : 376 / 510





Geometric Info:

All geometric product information are described in the Table 80.

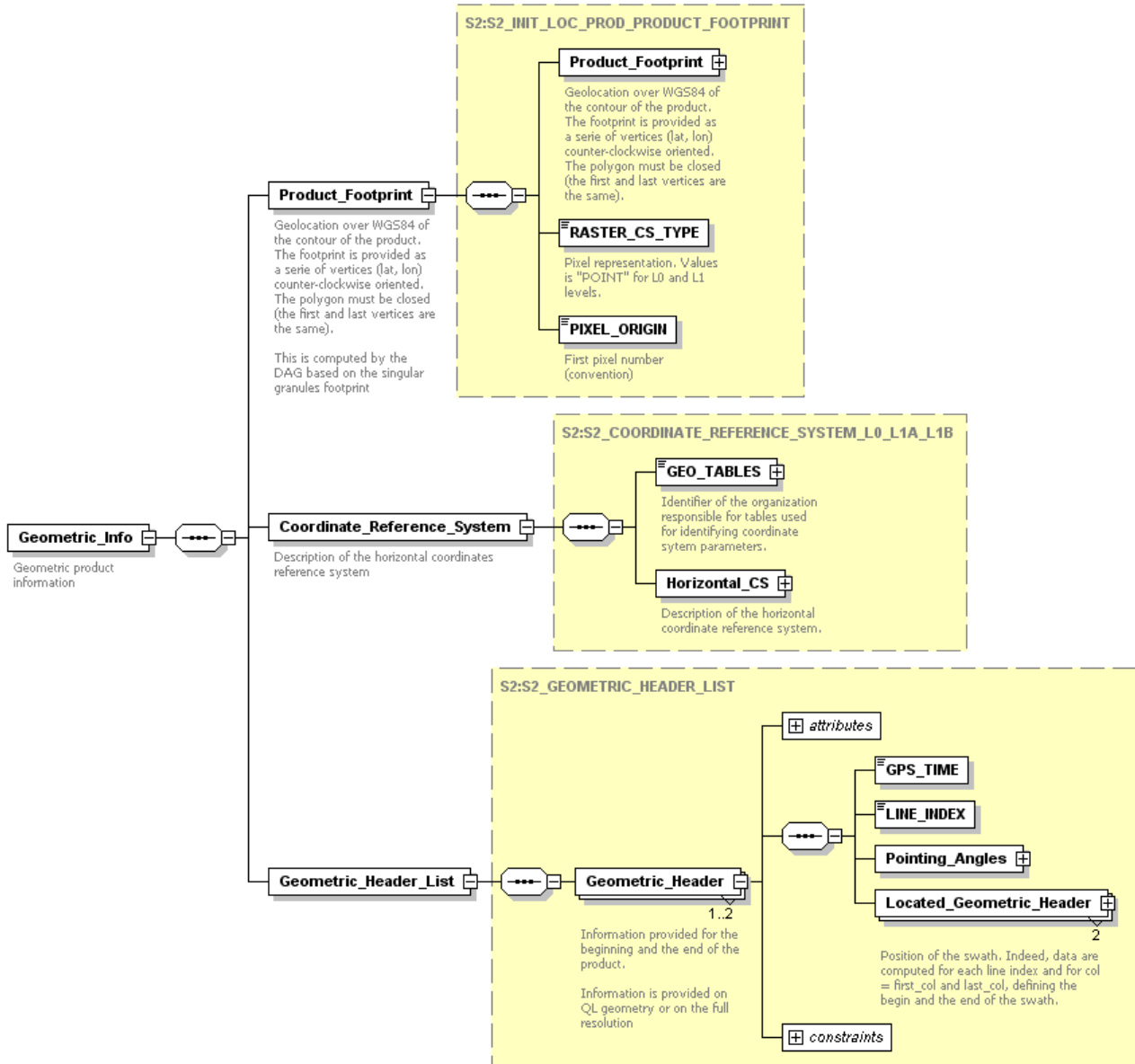

Generated by XMLSpy

www.altova.com

Figure 78: Level-1A Product\_Metadata\_File – Geometric\_Info Diagram

Auxiliary Data Info:

All auxiliary data information are described in the Table 81.

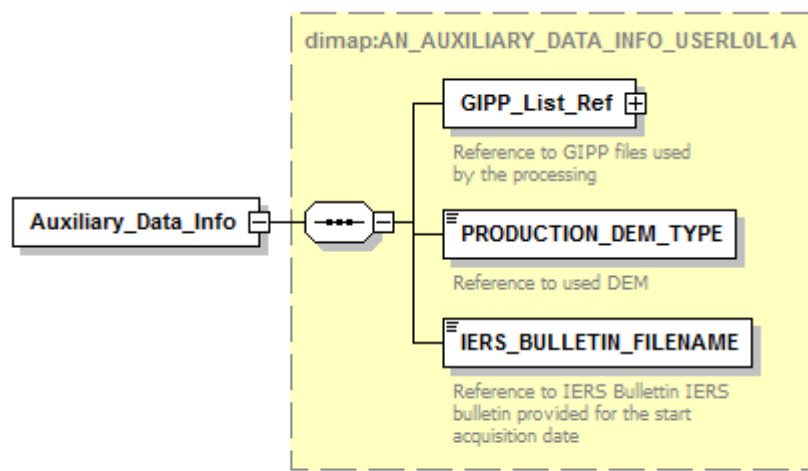

Generated by XMLSpy

www.altova.com

Figure 79 : Level-1A Product\_Metadata\_File – Auxiliary\_Data\_Info Diagram

Quality Indicators Info:

All Quality\_Indicators\_Info are the same described in the Table 82.

All OLQC checks performed on L1A Granules/Datastrips and related to a specific checklist name (cf. Annex C), are in the Table 3-17 and Table 3-24.

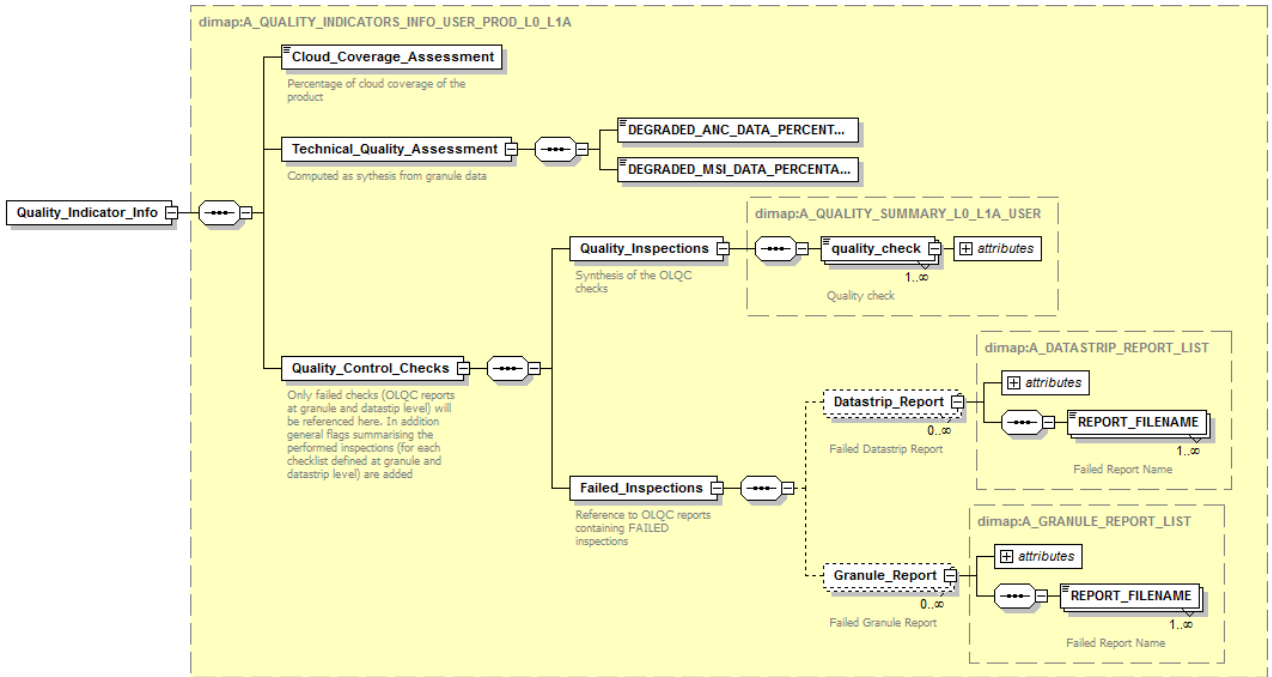

Generated by XMLSpy

www.altova.com

Figure 80 : Level-1A Product\_Metadata\_File – Quality\_Indicators\_Info Diagram

#### 4.7.7.2 GRANULE

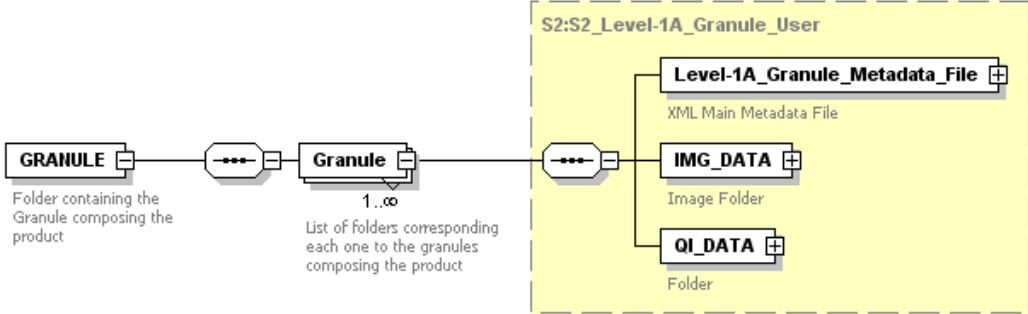
<p>diagram</p>	 <p align="center">Generated by XMLSpy <span style="float:right">www.altova.com</span></p>
<p>annotation</p>	<p>GRANULE folder is a “folder of folders” each one corresponding to the Granules composing the product and identified by proper PDI_ID (Granule_ID). The structure of each Granule included in the product is the same of the Level-1A Granule PDI described in the section 3.7.3 taking into account that:</p> <ol style="list-style-type: none"> <li>1. the Granule metadata copied in the User Product as they are except for the <i>metadataLevel</i> attribute (Brief/Standard/Expertise) always set as empty string (cf. section 4.7.6),</li> <li>2. the XML Level-1A_Granule_Metadata_File is validated using the <i>S2_PDI_Level-1A_Granule_Metadata.xsd</i> schema annexed to the document,</li> <li>3. the <i>Inventory_Metadata.xml</i>, <i>manifest.safe</i> and <i>rep_info</i> are removed when the Granule PDI is included in the User Product (cf. section 3.7.3).</li> </ol>

#### 4.7.7.3 DATASTRIP

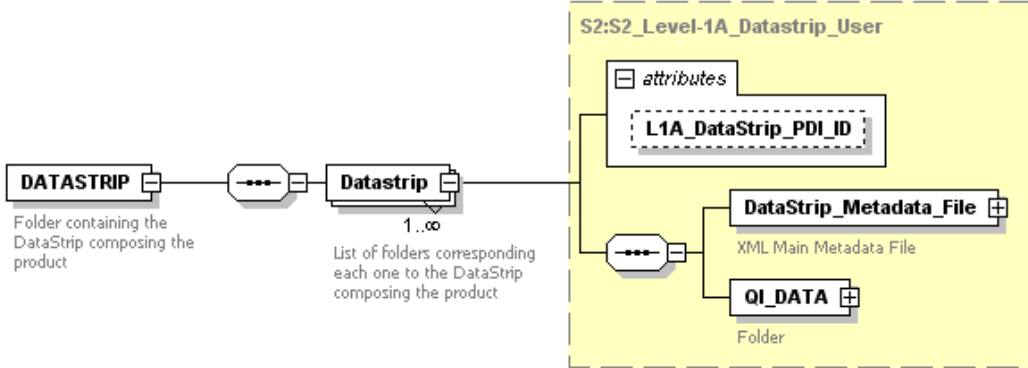
<p>diagram</p>	 <p align="center">Generated by XMLSpy <span style="float:right">www.altova.com</span></p>
<p>annotation</p>	<p>DATASTRIP folder is a “folder of folders” each one corresponding to the Datastrip composing the product and identified by proper PDI_ID (Datastrip_ID). The structure of each Datastrip included in the product is the same of the Level-1A Datastrip PDI described in the section 3.8.3 taking into account that:</p> <ol style="list-style-type: none"> <li>1. the Datastrips metadata are copied in the User Product as they are except for the <i>metadataLevel</i> attribute (Brief/Standard/Expertise) always set as empty string (cf.</li> </ol>

- section 4.7.6),
2. the XML Datastrip\_Metadata\_File is validated using the *S2\_PDI\_Level-1A\_Datastrip\_Metadata.xsd* schema annexed to the document,
  3. *Inventory\_Metadata.xml*, *manifest.safe* and *rep\_info* are removed when the Datastrip PDI is included in the User Product (cf. section 3.8.3).

#### 4.7.7.4 AUX\_DATA

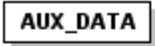
diagram	 <p>Folder containing (if requested by the user, download option) all Auxiliary Data used for the processing</p> <p align="center">Generated by XMLSpy <a href="http://www.altova.com">www.altova.com</a></p>
annotation	<p>All Auxiliary Data used for Level-1A processing are referenced through the Product_Metadata_File. GIPP files and IERS Bulletin file can be provided if requested by the user (download option). DEM is not provided itself inside the product but only as a reference to the data used.</p>

#### 4.7.7.5 Browse\_Image

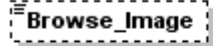
diagram	 <p>Browse Image File (PNG)</p> <p align="center">Generated by XMLSpy <a href="http://www.altova.com">www.altova.com</a></p>
annotation	<p>Browse Image file in PNG format. The Browse Image is included in the User Product if required by the user (download option). This Browse Image is based on the PVI extracted from the Level-1C Tile PDI (JPEG2000 low resolution extraction, 3 visible-bands in ground geometry at 320m resolution, RGB). The final geometric representation of the preview is defined by the user according to its region of interest (either geographic or cartographic representation).</p>

#### 4.7.8 Level-1A Granules Aggregation

As image viewer may not support well the high number of Granules constituting the L1A/L1B S2 User Products.

To handle more easily the Level-1A (and Level-1B) products, it is possible, when requested as a download-option, merge the Granule data and metadata of a Level-1A product (and Level-1B) along the satellite track direction.

This option (known as *concatenation of Granules along-track* or *aggregation of Granules*) allows to create one image per detector grouping all single Granules along track therefore producing at maximum 12 JPEG2000 images per band that can be displayed with a JPEG2000 viewer.

The following figure shows an example of L1A Granules (on the right) and L1A/L1B granules aggregated along-track (on the left) included in an Area-Of-Interest selected by the user.

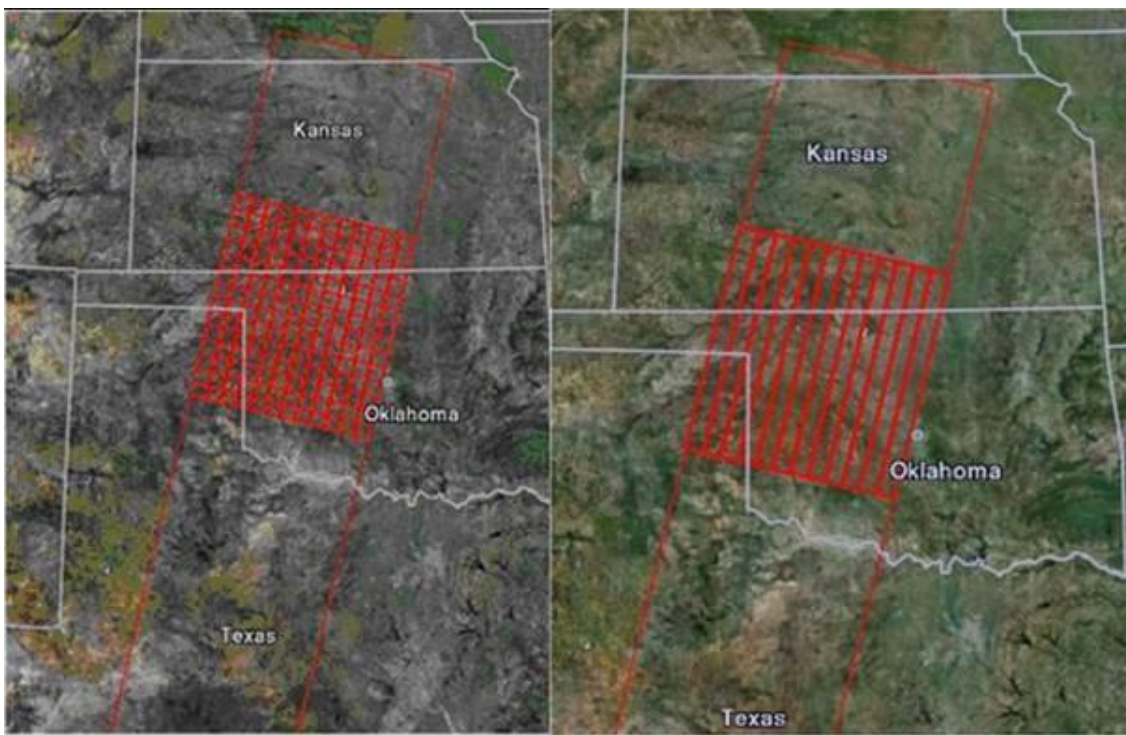

Figure 81 : Example of Level-1A Granules Aggregation

The Along-Track Aggregation Granules is a download option that can be selected by the user (cf. Section 4.4).

In this case the GRANULE folder of the User Product does not contain one folder for each elementary Granule composing the product but one folder for each Granule Aggregated and, as

mentioned above, the User Product contains at maximum 12 folders each one corresponding to one detector.

Inside each folder, there are 13 image data files in JPEG2000 format (one for each spectral band) stored in the IMG\_DATA sub-folder and ONE metadata file which envelops all the elementary Granules composing the aggregation.

#### 4.7.8.1 Aggregated Granules ID

The Granule ID in case of L1A and L1B Granule aggregated follows the same naming convention defined in the sections 3.7.1 and 3.9.1 with file type **MSI\_L1A\_GA** and **MSI\_L1B\_GA**.

File name template:

- S2A\_OPER\_MSI\_L1A\_GA\_SGS\_\_20130419T100000\_S20091211T165928\_D07\_N01.01
- S2A\_OPER\_MSI\_L1B\_GA\_SGS\_\_20130419T100000\_S20091211T165928\_D05\_N01.01

#### 4.7.8.2 Level-1A Aggregated Granules Physical Format

Based on Level-1A Granule PDI Physical format, the Granule aggregated is composed by:

- **Metadata\_File (one XML file):**

Template name:

S2A\_OPER\_MTD\_L1A\_GA\_SGS\_\_20130419T100000\_S20091211T165928\_D07.xml

Validated using the S2\_PDI\_Level-1A\_Granule\_Metadata.xsd schema annexed to the document.

- **IMG\_DATA (fixed folder name):**

Template names for the image files contained in the IMG\_DATA folder of the Granule aggregated corresponding to the Detector 7:

S2A\_OPER\_MSI\_L1A\_GA\_SGS\_\_20130419T100000\_S20091211T165928\_D07\_B01.jp2

S2A\_OPER\_MSI\_L1A\_GA\_SGS\_\_20130419T100000\_S20091211T165928\_D07\_B02.jp2

S2A\_OPER\_MSI\_L1A\_GA\_SGS\_\_20130419T100000\_S20091211T165928\_D07\_B03.jp2

...

S2A\_OPER\_MSI\_L1A\_GA\_SGS\_\_20130419T100000\_S20091211T165928\_D07\_B12.jp2

- **QI\_DATA (fixed folder name):**

QI\_DATA folder contains:

- All OLQC\_Report.xml reports;

Template filename:

S2A\_OPER\_MSI\_L1A\_GA\_SGS\_\_20130419T100000\_S20091211T165928\_D07\_SENSOR\_GEOMETRY.xml

- Quality\_Masks (one for each type, GML/JPEG2000).

Template masks filename:

S2A\_OPER\_MSK\_CLOLOW\_SGS\_\_00000000T000000\_S20091211T165928\_D07\_B00\_MSIL1A.gml

S2A\_OPER\_MSK\_DEFECT\_SGS\_\_00000000T000000\_S20091211T165928\_D07\_B00\_MSIL1A.gml

S2A\_OPER\_MSK\_NODATA\_SGS\_\_00000000T000000\_S20091211T165928\_D07\_B00\_MSIL1A.gml

S2A\_OPER\_MSK\_SATURA\_SGS\_\_00000000T000000\_S20091211T165928\_D07\_B00\_MSIL1A.gml

S2A\_OPER\_MSK\_TECQUA\_SGS\_\_00000000T000000\_S20091211T165928\_D07\_B00\_MSIL1A.gml

Note that the quality masks are aggregated as well. This means that the quality masks are generated performing an APPEND of all mask files related to each Granule concatenated.

#### 4.7.8.3 Metadata of Aggregated Granules

The metadata file envelops all the Granule metadata PDI composing the aggregation. The schema used to validate it is the same of the ones defined for L1A/L1B Granule PDI and annexed to the document.

The following table describes the meaning of each Granule metadata in case of Granule aggregated.

General_Info		
Field Name	L1A Granule	L1A Granule Aggregated
GRANULE_ID	Granule PDI Identifier.	Granule Aggregated Identifier as defined in the section 4.7.8.1.
DETECTOR_ID	Detector identifier.	Detector Identifier.
DATASTRIP_ID	Datastrip Identifier.	As the two uncompleted Tiles are on two Datastrip, this metadata contains two different Datastrip Identifiers.
DOWNLINK_PRIORITY	Downlink priority flag.	Downlink priority flag.
SENSING_TIME	Imaging Start Time in UTC data time.	Imaging Start Time in UTC data time.
Archiving_Info/ARCHIVING_CENTRE	Archiving Centre.	Archiving Centre.
Archiving_Info/ARCHIVING_TIME	Archiving date (UTC data time).	Archiving date (UTC data time).
Geometric_Info		
Field Name	Description	
Granule_Footprint/Granule_Footprint	Geolocation of the four corners of the elementary Granule (Lat, Lon, H coordinates with horizontal CRS as WGS84 and altitude given over EGM96).	Geolocation of the four corners of the Granule aggregated (Lat, Lon, H coordinates with horizontal CRS as WGS84 and altitude given over EGM96).
Granule_Footprint/RASTER_CS_TYPE	Pixel representation. Fixed values is "POINT".	Pixel representation. Fixed values is "POINT".



Granule_Footprint/PIXEL_ORIGIN	First pixel number (convention). Fixed value is "1".	First pixel number (convention). Fixed value is "1".
Granule_Position/POSITION	Position of the Granule in the Datatake. This position is identified through the position of the first line of the first scene in the Datatake and it is expressed as number of 10m resolution images lines.	Position of the Granule in the Datatake. This position is identified through the position of the first line of the first scene in the Datatake and it is expressed as number of 10m resolution images lines.
Granule_Position/Geometric_Head er/GROUND_CENTER	Geolocation of the Granule centre (Lat, Lon, H).	Geolocation of the centre (Lat, Lon, H) of the Granule aggregated.
Granule_Position/Geometric_Head er/QL_CENTER	The Granule centre in the QL display: 1 (r,c) point.	The Granule aggregated centre in the QL display: 1 (r,c) point.
Granule_Position/Geometric_Head er/Incidence_Angles	Incidence angles corresponding to the centre of the Granule.	Incidence angles corresponding to the centre of the Granule aggregated.
Granule_Position/Geometric_Head er/Solar_Angles	Solar angles corresponding to the centre of the Granule.	Solar angles corresponding to the centre of the Granule aggregated.
Granule_Dimension/Size/NROWS	Granule dimensions provided for each resolution band (10m, 20m and 60m)  Number of Row	Granule aggregated dimensions provided for each resolution band (10m, 20m and 60m)  Total Number of Row
Granule_Dimension/Size/NCOLS	Granule dimensions provided for each resolution band (10m, 20m and 60m)  Number of Columns	Granule aggregated dimensions provided for each resolution band (10m, 20m and 60m)  Number of Columns  It is the same of an elementary Granule.

Quality Indicators Info		
Field Name	Description	
Image_Content_QI/CLOUDY_PIXEL_PERCENTAGE	Percentage of cloud coverage for each L1A Granule.	Average of the percentage of cloud coverage computed for each L1A Granule composing the Granule aggregated.
Image_Content_QI/DEGRADED_MSI_DATA_PERCENTAGE	Percentage of degraded MSI data for each L1A Granule.	Average of the percentage of degraded MSI data computed for each L1A Granule composing the Granule aggregated.
Pixel_Level_QI/MASK_FILENAME	Pointer to the mask files contained in the QI_DATA folder of the Granule.	Pointer to the mask files contained in the QI_DATA



**Sentinel-2 Products  
Specification Document**

REF : S2-PDGS-TAS-DI-PSD  
ISSUE : 14.5  
DATE : 14/03/2018  
PAGE : 386 / 510

folder of the Granule  
aggregated.

An example of the Granules aggregated metadata file is provided in the Annex F.

Note that the Aggregation option is addressed at product level setting TRUE the AGGREGATION\_FLAG metadata.



#### 4.7.9 User Product Level-1A SAFE Manifest synoptic table

The final User Product contains only one main *manifest.safe* file. The *manifest.safe* files related to each Granules/Datastrips composing the product are available at PDI level but they are not included in the User Product, all lower level PDI are removed.

This chapter provides a detailed description of the content of the SAFE Manifest for the Level-1A User Product, including a synoptic table with the list of the metadata information to be included in the SAFE Manifest.

Since the User Product metadata refers to the contained Granules and Datastrips, the structure of the Manifest is based on the Level-1A Manifests provided for Granules and Datastrip (cf. sections 3.7.4 and 3.8.4).

Same considerations as in section 4.6.8 applies for what concerns compliancy to SAFE specification [SAFE-SPEC] and content of the synoptic tables, with the exception that the Data Objects Section does not contain, differently from the Level-0 User Product, an ANC\_DATA folder.

A practical example of Manifest file for the Level-1A User Product is provided as annexed zip file to this document (S2-PDGS-TAS-DI-PSD-V14\_SAFE.zip).

SAFE Manifest		Corresponding metadata in the S2_User_Product_Level-1A_Metadata.xsd	Description	Data Type	Occurrence	Allowed range of values
Metadata name	Name of tag or attribute (in bold)	Tag name				
platform						
	nssdcIdentifier	N.A.	Unique identifier of the platform, defined by the World Data center for Satellite Information (WDC-SI)		1	WDC is discontinued; this tag is set to a default value 0000-0000
	familyName	Level-1A_User_Product->General_Info->Product_Info->Datatake->SPACECRAFT_NAME	The mission name of the platform	string enum	0..1	Sentinel
	number	Level-1A_User_Product->General_Info->Product_Info->Datatake->SPACECRAFT_NAME	Sequence identifier of the platform among the mission	string enum	0..1	2A, 2B, 2C
	instrument->familyName	N.A.	The instrument name used for acquiring the product data	string enum	0..1	Multi-Spectral Instrument
	instrument-> <b>abbreviation</b>	N.A.	Abbreviation of the instrument name	string enum	0..1	MSI
	instrument->mode	Level-1A_User_Product->General_Info->Product_Info->Datatake->DATATAKE_TYPE	The mode of the instrument	string enum	0..1	Nominal_Observation Dark_Signal_Calibration Extended_Observation Absolute_Radiometry_Calibration Vicarious_Calibration Raw_Measurement Test_Mode

SAFE Manifest		Corresponding metadata in the S2_User_Product_Level-1A_Metadata.xsd	Description	Data Type	Occurrence	Allowed range of values
Metadata name	Name of tag or attribute (in bold)	Tag name				
	instrument->mode-> <b>identifier</b>	Level-1A_User_Product->General_Info->Product_Info->Datatake->DATATAKE_TYPE	The identifier of the instrument mode	string enum	1	INS-NOBS INS-EOBS INS-DASC INS-ABSR INS-VIC INS-RAW INS-TST
processing			Textual description of the history of processings that lead to the current product and of all the relevant resources involved in the processing (facilities, software, applicable documents etc)		1	
	<b>name</b>		Name of the L0 to L1A Processing	string	0..1	Generation of L1A User Product
	<b>start</b>	Level-1A_User_Product->General_Info->Product_Info->GENERATION_TIME	Processing start date (UTC)	xs:dateTime	0..1	
	facility	N.A.	Description of Processing Centre		0..*	
	facility-> <b>name</b>	N.A.	Extended name of Origin Centre	string	1	
	facility-> <b>organization</b>	N.A.	Organization to which the Origin center belongs	string	0..1	
	facility-> <b>site</b>	Level-1A_User_Product->GRANULE->General_Info->GRANULE_ID (substring <Site Centre>, cf. section 3.5.6)	Acronym of the Processing center	string enum	0..1	SGS_ MPS_ MTI_ EPA_ MPC_



**Sentinel-2 Products  
Specification Document**

REF : S2-PDGS-TAS-DI-PSD  
 ISSUE : 14.5  
 DATE : 14/03/2018  
 PAGE : 390 / 510

SAFE Manifest		Corresponding metadata in the S2_User_Product_Level-1A_Metadata.xsd	Description	Data Type	Occurrence	Allowed range of values
Metadata name	Name of tag or attribute (in bold)	Tag name				
						UPA_XXXX EDRS zzzL (zzz = first three characters of the LGS location)
	facility-> <b>country</b>	N.A.	Country where Origin Centre is located	string	0..1	
	facility->software	N.A.	Description of software component used for Processing		0..*	
	facility->software-> <b>name</b>	N.A.	Name of the software component	string	1	
	facility->software-> <b>version</b>	N.A.	Version of the software component	string	0..1	
	resource		List of auxiliary data files used by the processors to support radiometric and geometric correction (GIPP, DEM, GRI, IERS Bulletin etc.) and of SAD Raw Data file containing the satellite ancillary telemetry; these files are provided with the product.		0..*	
	resource-> <b>name</b>	Level-1A_User_Product->DATASTRIP->Satellite_Ancillary_Data_Info->ANC_DATA_REF (reference to the folder containing the SAD Raw Data files)	Name of the auxiliary or ancillary files/folders needed for the Processing	string	1	





**Sentinel-2 Products  
Specification Document**

REF : S2-PDGS-TAS-DI-PSD  
ISSUE : 14.5  
DATE : 14/03/2018  
PAGE : 391 / 510

SAFE Manifest		Corresponding metadata in the S2_User_Product_Level-1A_Metadata.xsd	Description	Data Type	Occurrence	Allowed range of values
Metadata name	Name of tag or attribute (in bold)	Tag name				
		Level-1A_User_Product->DATASTRIP->Auxiliary_Data_Info->IERS_Bulletin  Level-1A_User_Product->DATASTRIP->Auxiliary_Data_Info->GIPP_List->GIPP_FILENAME				
	resource-> <b>role</b>	N.A.	Role of the resource	string	1	Auxiliary data, Ancillary data
acquisitionPeriod					1	
	acquisitionPeriod ->startTime	Level-1A_User_Product->General_Info->Product_Info->Datatake->DATATAKE_SENSING_START	Reference time of acquisition of the product	xs:dateTime	1	
measurementFrameSet					1	
	footPrint	Derived from Level-1A_User_Product->Geometric_Info->Product_Footprint	Product footprint (namely imaged landscape corresponding to the whole product)	string (gml:linearRingType namely blank separated list of comma-separated long/lat coordinates of footprint closed polygon with last vertex equal to first)	0..1	
measurementOrbitReference						



SAFE Manifest		Corresponding metadata in the S2_User_Product_Level-1A_Metadata.xsd	Description	Data Type	Occurrence	Allowed range of values
Metadata name	Name of tag or attribute (in bold)	Tag name				
	orbitNumber	Level-1A_User_Product->General_Info->Product_Info->Datatake->DatatakeIdentifier (substring <AbsoluteOrbitNumber>)	Absolute orbit number		0..1	> 0
	orbitNumber-> <b>type</b>	N.A.	Absolute orbit number type (possible values "start" or "stop"). Set to "start" since the absolute orbit number refers to the first line of the first Granule of the User Product		0..1	start
	orbitNumber-> <b>groundTrackDirection</b>	Level-1A_User_Product->General_Info->Product_Info->Datatake->SENSING_ORBIT_DIRECTION	Direction of the ground track of the Sentinel-2 platform at the time corresponding to orbitNumber->type (start or stop)		0..1	ascending, descending
	relativeOrbitNumber	Level-1A_User_Product->General_Info->Product_Info->Datatake->SENSING_ORBIT_NUMBER	Relative orbit number (within the cycle)		0..1	1 to 143
	relativeOrbitNumber-> <b>type</b>	N.A.	Relative orbit number type (possible values "start" or "stop"). Set to "start" since the absolute orbit number refers to the first line of the Datastrip		0..1	start
metadataComponents		Level-1A_User_Product->DATASTRIP->Satellite_Ancillary_Data_Info->ANC_DATA_REF (reference to the folder containing the SAD Raw Data files)  Level-1A_User_Product->DATASTRIP->	A reference to all ancillary/auxiliary Metadata files/folders included in the product (e.g. the XML Metadata file, the INSPIRE		1..*	





**Sentinel-2 Products  
Specification Document**

REF : S2-PDGS-TAS-DI-PSD  
 ISSUE : 14.5  
 DATE : 14/03/2018  
 PAGE : 393 / 510

SAFE Manifest		Corresponding metadata in the S2_User_Product_Level-1A_Metadata.xsd	Description	Data Type	Occurrence	Allowed range of values
Metadata name	Name of tag or attribute (in bold)	Tag name				
		Auxiliary_Data_Info-> IERS_Bulletin Level-1A_User_Product->DATASTRIP-> Auxiliary_Data_Info-> GIPP_List->GIPP_FILENAME	Metadata file, the Auxiliary Data files) or external to the product (the Ancillary Data files)			
metadataComponentSchemas		N.A	A reference to the Schemas used to validate the Metadata files included in the product (e.g. the XML Metadata file Schema)		0..1	

Table 88 - Content of Metadata section for Level-1A User Product SAFE Manifest



## 4.8 Level-1B User Product specification

### 4.8.1 Introduction

The Level-1B User Product is a *Radio-corrected and geo-refined* product obtained by performing radiometric corrections on the Level-1A data and refining its geometric model.

The Radiometric corrections are applied to obtain a Level-1B User Product but the geo-refinement model is only appended to the metadata and never applied to the product.

The following table introduces the input data of Level-1B processing:

Input of Level-1B processing	Description
Metadata	Metadata from Level-1A product
Image Data	Uncompressed image data (from Level-1A, in the data flow)
Auxiliary Data	GIPP : Parameters from Level-1A complemented by radiometric and geometric processing parameters. GRI (Global Reference Images): only the reference to the data used is provided. DEM: only the reference to the data used is provided.
Quality Indicator Data	Quality Indicator files from Level-1B

Table 89: Input for Level-1B processing

The Level-1B corrections include:

- Radiometric corrections:
  - dark signal
  - pixel response non uniformity
  - crosstalk correction
  - defective pixels
  - High spatial resolution bands restoration: deconvolution and denoising based on a wavelet processing (if necessary according to certain noise criteria).
  - Binning for 60m bands (spatial filtering)
- Physical geometric model refinement using GCPs provided by the GRI; this model is not applied to the image but appended to the metadata
- Pixel classification: singular pixels detections (defectives pixels, saturations, nodata).

No resampling is performed up to Level-1B.

The geometric model refinement of the Level-1B is optional. A dedicated flag in the metadata notifies whether the geometric model provided is the raw model or the refined model.

Note that one Level-1B product:

- refers always to one Datatake;
- refer to one or several Datastrip from the same Datatake;
- may cover the full Datatake or an extract of the Datatake.

In the case of an extract, the image data are provided to cover only the selected area.

The following figure gives an overview of the Level-1B User Product physical format. The yellow boxes correspond to folders and the white ones to files:

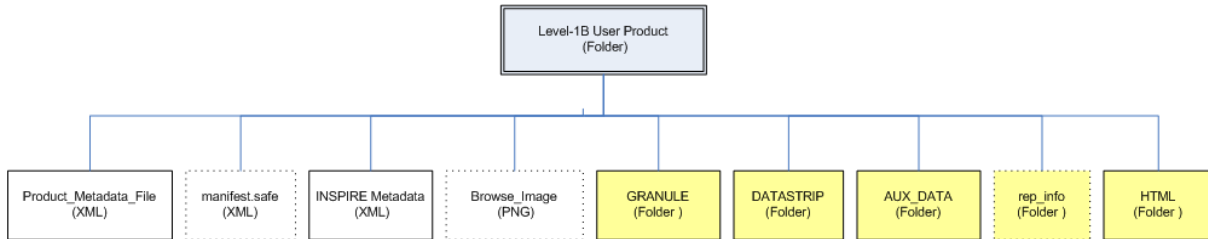

Figure 82: Level-1B User Product Structure

The Level-1B User Product consists of:

1. **Product\_Metadata\_File**: mandatory XML main metadata file.
2. **manifest.safe**: SAFE metadata file (optional). It is included in the product only if the user requests the SAFE as output format (download option).
3. **GRANULE**: folder containing all Granules composing the product (Image Data). The Image Data extent (raster files) correspond to a set of Granules and can covers up to *12 detectors \* 13 bands* of the orbit in full resolution. A sub-set of the 13 bands can be provided (download option).
4. **DATASTRIP**: folder containing the Datastrip composing the product linked to the selected Granules.
5. **AUX\_DATA**: folder containing, if requested by the user (download option), the GIPP files and IERS Bulletins used for the Level-1B User Product production. All Level-1B auxiliary data are referenced in the product metadata file.
6. **Browse\_Image**: PNG file consisting of an image limited to 3 visible-bands in ground geometry at 320m resolution. This file, provided if requested by the user (download option), gives an overview of the product (sub-sampled) mainly for image data browsing and selection purposes.
7. **rep\_info**: folder containing the XSD schema provided inside the product. This folder is optional. It is included in the User Product if the user selects the SAFE format as output format (download option).
8. **INSPIRE**: XML INSPIRE metadata file (cf. Annex B).
9. **HTML**: folder containing an HTML product presentation file (UserProduct\_index.html) and the corresponding stylesheet (UserProduct\_index.xsl).

#### 4.8.2 Image Data

The Level-1B image data correspond to a collection of Granules. The image data extent correspond to a set of Granules and can cover *up to 12 detectors \* 13 bands of the orbit in full resolution*. A sub-set of the 13 bands can be provided (same approach as Level-1A).

Each Level-1B Granule is identified in a unique way, using a unique identifier PDI\_ID defined in the section 3.9.1.

#### 4.8.2.1 Image Data Encoding and Files

Each image pixel value is encoded on 12 useful bits (as on-board).

The image data are provided as separated files for each spectral band (i.e. in total of 13 GML/JPEG2000 files per Granule).

As per a Level-1A product, the Level-1B product will be available to the final user according to two delivery options:

- Either one file per spectral band and per Granule;
- Either a file per spectral band corresponding to the concatenation of *Granules along-track* also called *aggregation of Granules* (§ 4.7.8).

#### 4.8.3 Ancillary Data

The raw Satellite Ancillary Data are not embedded in the Level-1B User.

#### 4.8.4 Auxiliary Data

All Auxiliary Data used for Level-1B processing are referenced in the product metadata file:

- IERS bulletin file,
- Ground Image Processing Parameters (GIPPs) files (cf. Annex D),
- Reference to the used DEM;
- Reference to the used GRI.

The final user, according to a specific download option, will be able to include in the Level-1B User Product, the IERS bulletin and/or the used GIPP files. DEM and GRI are never provided within the product but only referenced at metadata level.

#### 4.8.5 Quality Indicators

Level-1B quality indicators are derived from Level-1A ones and are complemented by quality indicators relevant to the processing applied.

The *Product Level Quality Indicators* are provided at product level and referenced through the metadata file.

The *Granule Level Quality Indicators* are provided at Granule level and referenced through the metadata file.

The *Pixel Level Quality Indicators* are provided at Granule level through dedicated quality mask files pointed through the Granule level metadata file.



**Sentinel-2 Products  
Specification Document**

REF : S2-PDGS-TAS-DI-PSD

ISSUE : 14.5

DATE : 14/03/2018

PAGE : 397 / 510



#### 4.8.6 Metadata

The following table shows the groups of metadata provided inside a Level-1B User Product:

Level-1B User Product Metadata	
<b>Product Level Metadata</b>	All product level metadata, specific for the User level, are consolidated/computed because not present at Granule and Datastrip level.
<b>Granule Level Metadata (Brief/Standard/Expertise)</b>	All Brief/Standard/Expertise metadata (download option, cf. section 4.4) defined at Granule level are copied from the input Granules to the User Product.
<b>DATASTRIP Level Metadata (Brief/Standard/Expertise)</b>	All Brief/Standard/Expertise metadata (download option, cf. section 4.4) defined at Datastrip level are copied from the input Datastrips to the User Product;

Table 90: Level-1B Product Metadata

As mentioned in the section 2.10, the User Product metadata (all) are not provided with a *metadataLevel* attribute (Brief/Standard/Expertise) unlike what happens for all Granule and Datastrip metadata.

During the User Product assembling, this attribute is used to select by filtering, according to a download option, the set of metadata that must be included in the User Product.

For these filtered fields, the *metadataLevel* attribute is not written in the User Product's metadata.

Note that a User Product for an expert user (Expertise download option) will contain all level of metadata (Brief/Standard/Expertise). A User Product for a user with "Standard" or "Brief" permission will contain only Brief/Standard or Brief metadata.

In addition to the metadata in the table above, the User Product contains the *manifest.safe* metadata (when the User Product is SAFE format) and the INSPIRE metadata.

The Level-1B Product Metadata are detailed in the section 4.8.7.

#### 4.8.7 User Product Level-1B Structure

The *S2\_User\_Product\_Level-1B\_Structure.xsd* schema annexed to the document and shown in the following diagram, represents the structure of a S2 Level-1B User Product. This schema is provided for information only as it is actually not expected to be used for the validation of a XML file. The diagram reflects exactly the structure shown in the Figure 72.

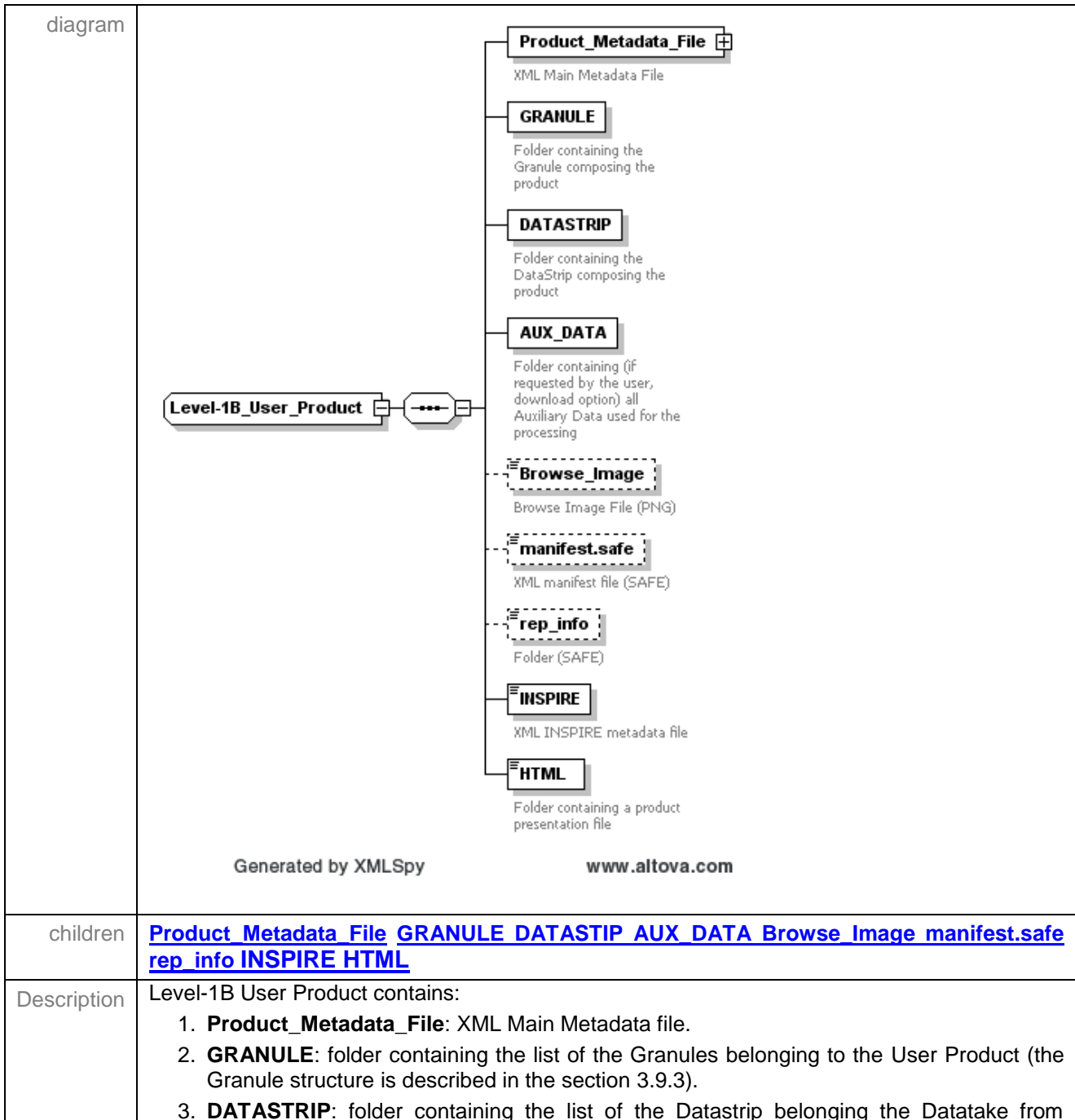

which Level-1B User Product has been selected (the Datastrip structure is described in the section 3.10.3). .

4. **AUX\_DATA**: folder containing all Auxiliary Data used for Level-1B processing (optional, the aux data will be included in the product if selected according to a specific download option).
5. **Browse\_Image**: PNG file for image data browsing and selection purposes.
6. **manifest.safe**: XML SAFE Manifest file
7. **rep\_info**: optional folder containing the XSD schema
8. **INSPIRE.xml**: XML INSPIRE metadata file
9. **HTML**: folder containing an HTML product presentation file and the corresponding stylesheet



#### 4.8.7.1 Product\_Metadata\_File Schema

Product\_Metadata\_File is the XML metadata file provided inside the S2 Level-1B User Product. The XSD schema annexed to this document and used to validate it is *S2\_User\_Product\_Level-1B\_Metadata.xsd*.

A detailed description of the schema is given here but for specific details regarding each metadata (e.g. type, default value, fixed value, enumerations, occurrences, etc...) refers to the XSD file.

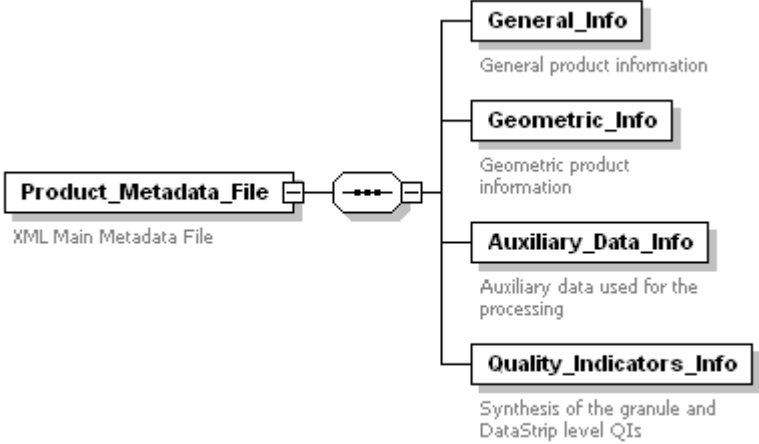
<p>diagram</p>	 <p align="center">Generated by XMLSpy <span style="float:right">www.altova.com</span></p>
<p>children</p>	<p><a href="#">General_Info</a> <a href="#">Geometric_Info</a> <a href="#">Auxiliary_Data_Info</a> <a href="#">Quality_Indicators_Info</a></p>
<p>Description</p>	<p>The Product_Metadata_File describes the product data items. It is presented to the user as a structured container of information. Product_Metadata_File is an XML file containing:</p> <ol style="list-style-type: none"> <li>1. <b>General_Info</b>: provides general product information.</li> <li>2. <b>Geometric_Info</b>: describing the geolocation over WGS84 of the contour of the product.</li> <li>3. <b>Auxiliary_Data_Info</b>: Links to the AUX_DATA items.</li> <li>4. <b>Quality_Indicators_Info</b>: Synthesis of the Granule and Datastrip level QIs.</li> </ol>

The following figures and tables give a complete description of the User Product metadata.

General Info:

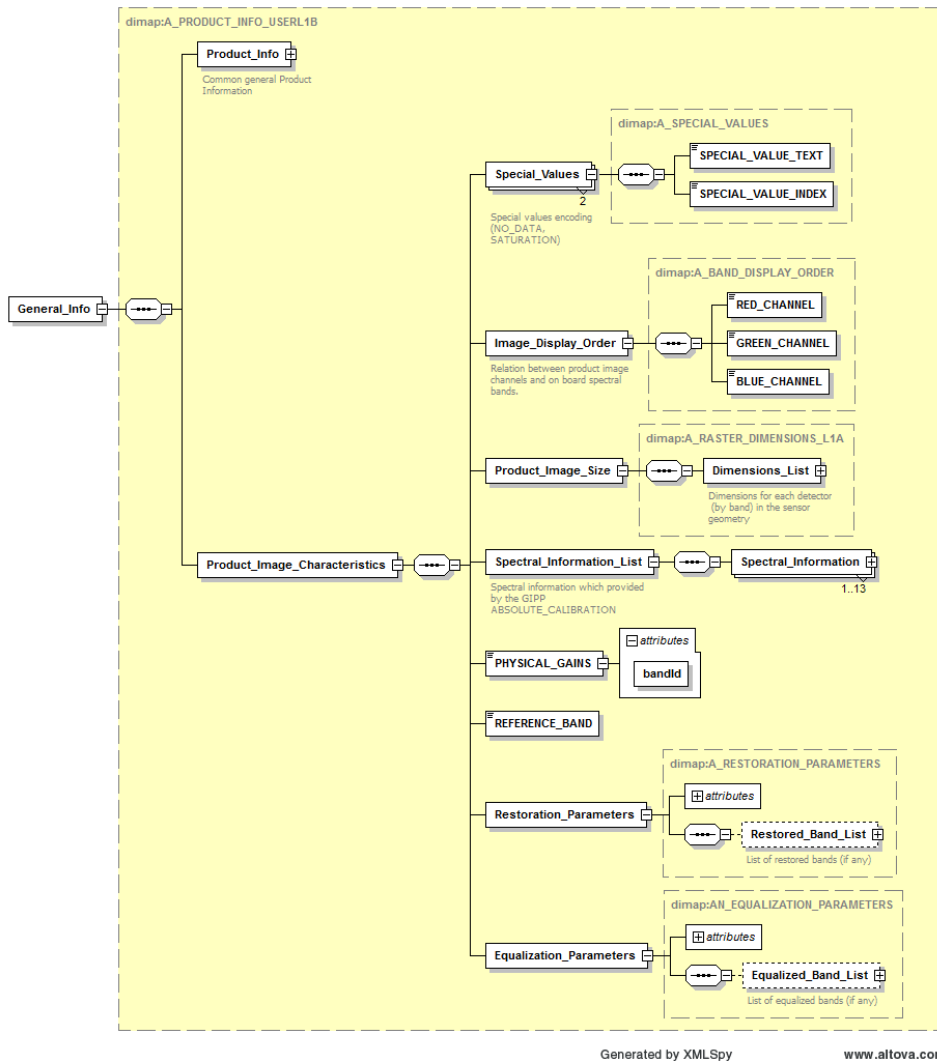

Figure 83 : Level-1B Product\_Metadata\_File - General\_Info Diagram



## Sentinel-2 Products Specification Document

REF : S2-PDGS-TAS-DI-PSD  
 ISSUE : 14.5  
 DATE : 14/03/2018  
 PAGE : 403 / 510

General_Info		
Field Name	Description	Note
Product_Info	This group of metadata is described in the Table 79.	Table 79
Product_Image_Characteristics/Special_Values/SPECIAL_VALUE_TEXT Product_Image_Characteristics/Special_Values/SPECIAL_VALUE_INDEX	Special values encoding (e.g. NODATA, SATURATION)	Based on Radiometric_Info (PIXELS_NO_DATA_PROC and SATURATED_PIXELS_PROC) available at Datastrip level.
Product_Image_Characteristics/Image_Display_Order/RED_CHANNEL Product_Image_Characteristics/Image_Display_Order/GREEN_CHANNEL Product_Image_Characteristics/Image_Display_Order/BLUE_CHANNEL	Spectral bands (Relation between product image channels and on board spectral bands)	Information available at Datastrip level (cf. Table 53).
Product_Image_Characteristics/Product_Image_SizeDimension_List/Dimensions/ Detector_Dimensions/NROWS Product_Image_Characteristics/Product_Image_SizeDimension_List/Dimensions/ Detector_Dimensions/NCOLS	Product Image size (by band x detector)	Based on Granule dimensions
Product_Image_Characteristics/Spectral_Information_List/Spectral_Information/RESOLUTION Product_Image_Characteristics/Spectral_Information_List/Spectral_Information/Wavelength/MIN Product_Image_Characteristics/Spectral_Information_List/Spectral_Information/ Wavelength/MAX Product_Image_Characteristics/Spectral_Information_List/Spectral_Information/ Wavelength/CENTRAL Product_Image_Characteristics/Spectral_Information_List/Spectral_Information/Spectral_Response/STEP Product_Image_Characteristics/Spectral_Information_List/Spectral_Information/Spectral_Response/VALUES	Spectral filter information provided by the GIPP ABSOLUTE_CALIBRATION	Information available at Datastrip level
Product_Image_Characteristics/PHYSICAL_GAINS	Physical Gain for each band	
Product_Image_Characteristics/REFERENCE_BAND	Reference Band used in the processing	
Restoration_Parameters/Restored_Band_List/Restored_Band/RESTORATION_SCENARIO Restoration_Parameters/Restored_Band_List/Restored_Band/Levelling_Values/XMIN Restoration_Parameters/Restored_Band_List/Restored_Band/Levelling_Values/XMAX	Restoration parameters (list of restored bands, type of restoration and levelling)	Available at Datastrip level, cf. Table 53





## Sentinel-2 Products Specification Document

REF : S2-PDGS-TAS-DI-PSD  
ISSUE : 14.5  
DATE : 14/03/2018  
PAGE : 404 / 510

General_Info		
Field Name	Description	Note
	values).	
Equalization_Parameters/Equalized_Band_List/Equalized_Band/OFFSET_PROC Equalization_Parameters/Equalized_Band_List/Equalized_Band/DARK_SIGNAL_NON_UNIFORMITY_PROC	Equalization parameters	Available at Datastrip level, cf. Table 53

Table 91: Level-1B Product\_Metadata\_File - General\_Info Description



Geometric Info:

all geometric product information are described in the Table 80.

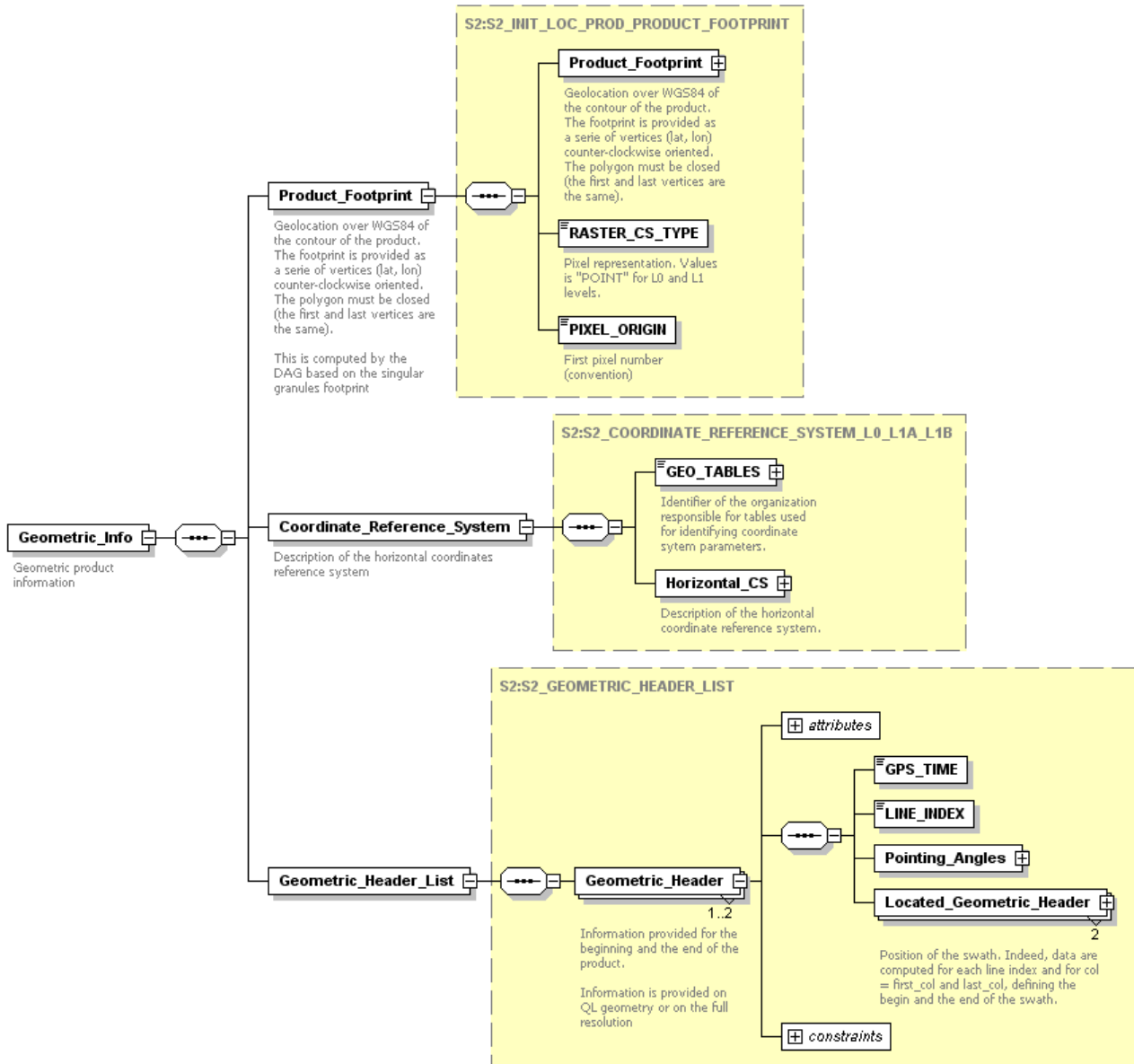

Generated by XMLSpy

www.altova.com

Figure 84: Level-1B Product\_Metadata\_File – Geometric\_Info Diagram

Auxiliary Data Info:

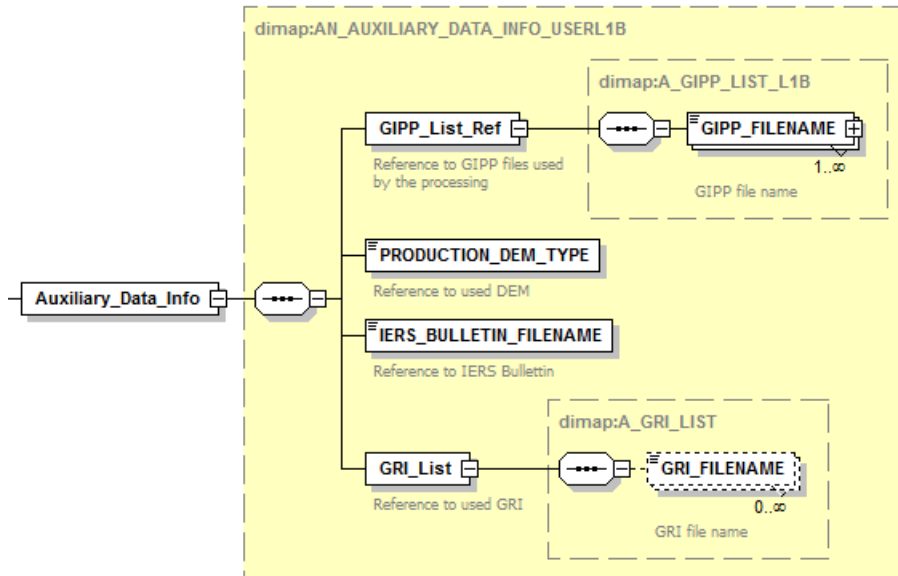

Figure 85 : Level-1B Product\_Metadata\_File – Auxiliary\_Data\_Info Diagram

Auxiliary_Data_Info		
Field Name	Description	Note
GIPP_FILENAME	Reference to the used GIPP files.	Available at Datastrip level, cf. Table 55
PRODUCTION_DEM_TYPE	Reference to the used DEM	Available at Datastrip level, cf. Table 55
IERS_BULLETIN_FILENAME	Reference to the used IERS Bulletin	Available at Datastrip level, cf. Table 55
GRI_FILENAME	Reference to the used GRI data	Available at Datastrip level, cf. Table 55

Table 92: Level-1B Product\_Metadata\_File - Auxiliary\_Info Description

Quality Indicators Info:

The Quality\_Indicators\_Info are described in the Table 82.

In addition the Level-1B User Product contains the RADIOMETRIC\_QUALITY check based on the OLQC reports contained in the Datastrips/QI\_DATA with RADIOMETRIC\_QUALITY checklist name.

RADIOMETRIC\_QUALITY check is FAILED if at least one report at Datastrip level is with *globalStatus* FAILED.

All OLQC checks performed on L1B Granules/Datastrips and related to a specific checklist name (cf. Annex C), are in the Table 3-17 and Table 3-24.

#### 4.8.7.2 GRANULE

<p>diagram</p>	<p align="center">Generated by XMLSpy <span style="float:right">www.altova.com</span></p>
<p>annotation</p>	<p>GRANULE folder is a “folder of folders” each one corresponding to the Granules composing the product and identified by proper PDI_ID (Granule_ID). The structure of each Granule included in the product is the same of the Level-1B Granule PDI described in the section 3.9.3 taking into account that:</p> <ol style="list-style-type: none"> <li>1. the Granule metadata are copied in the User Product as they are except for the <i>metadataLevel</i> attribute (Brief/Standard/Expertise) always set as empty string (cf. section 4.8.6),</li> <li>2. the XML Level-1B_Granule_Metadata_File is validated using the <i>S2_PDI_Level-1B_Granule_Metadata.xsd</i> schema annexed to the document,</li> <li>3. the <i>Inventory_Metadata.xml</i>, <i>manifest.safe</i> and <i>rep_info</i> are removed when the Granule PDI is included in the User Product (cf. section 3.9.3).</li> </ol>

#### 4.8.7.3 DATASTRIP

<p>diagram</p>	<p align="center">Generated by XMLSpy <span style="float:right">www.altova.com</span></p>
<p>annotation</p>	<p>DATASTRIP folder is a “folder of folders” each one corresponding to the Datastrip composing the product and identified by proper PDI_ID (Datastrip_ID). The structure of each Datastrip included in the product is the same of the Level-1B Datastrip PDI described in the section 3.10.3 taking into account that:</p>

1. the Datastrips metadata are copied in the User Product as they are except for the *metadataLevel* attribute (Brief/Standard/Expertise) always set as empty string (cf. section 4.8.6),
2. the XML Datastrip\_Metadata\_File is validated using the *S2\_PDI\_Level-1B\_Datastrip\_Metadata.xsd* schema annexed to the document,
3. *Inventory\_Metadata.xml*, *manifest.safe* and *rep\_info* are removed when the Datastrip PDI is included in the User Product (cf. section 3.10.3).

#### 4.8.7.4 AUX\_DATA

diagram	 <p>Folder containing (if requested by the user, download option) all Auxiliary Data used for the processing</p> <p align="center">Generated by XMLSpy <a href="http://www.altova.com">www.altova.com</a></p>
annotation	<p>All Auxiliary Data used for Level-1B processing are referenced through the Product_Metadata_File. GIPP files and IERS Bulletin file can be provided if requested by the user (download option). DEM and GRI are not provided itself inside the product but only as a reference to the data used.</p>

#### 4.8.7.5 Browse\_Image

diagram	 <p>Browse Image File (PNG)</p> <p align="center">Generated by XMLSpy <a href="http://www.altova.com">www.altova.com</a></p>
annotation	<p>Browse Image file in PNG format. The Browse Image is included in the User Product if required by the user (download option). This Browse Image is based on the PVI extracted from the Level-1C Tile PDI (JPEG2000 low resolution extraction, 3 visible-bands in ground geometry at 320m resolution, RGB). The final geometric representation of the preview is defined by the user according to its region of interest (either geographic or cartographic representation).</p>



#### 4.8.8 User Product Level-1B SAFE Manifest synoptic table

The final User Product contains only one main *manifest.safe* file. The *manifest.safe* files related to each Granules/Datastrips composing the product are available at PDI level but they are not included in the User Product, all lower level PDI are removed.

The content of the SAFE Manifest for the Level-1B User Product level is the same as for the Level-1A User Product level and can be exhaustively described through Table 31, Table 83 and Table 83 , except for the following minor differences in Table 83:

- a few specific text string in the “processing” section (containing “L1B” instead of “L1A”)
- the Level-1B User Product Manifest includes a reference to the GRI Auxiliary file, contained in the AUX\_DATA folder (differently from Level-1A User Product); see tag “metadataComponents” in Table 83.

Since the User Product metadata refers to the contained Granules and Datastrips, the structure of the Manifest is based on the Level-1B Manifests provided for Granules and Datastrip (cf. sections 3.9.4 and 3.10.4).

A practical example of Manifest file for the Level-1B User Product is provided as annexed zip file to this document (S2-PDGS-TAS-DI-PSD-V14\_SAFE.zip).

## 4.9 Level-1C User Product Specification

### 4.9.1 Introduction

The Level-1C User Product is an orthoimage product, i.e. a map projection of the acquired image using a system DEM to correct ground geometric distortions. Pixel radiometric measurements are provided in Top-Of-Atmosphere (TOA) reflectances with all parameters to transform them into radiances.

The conversion formulae to apply to image Digital Numbers (DN) to obtain physical values is:

Reflectance (float) =  $DC / (QUANTIFICATION\_VALUE)$

Note that the reflectance meaningful values go from "1" to "65535" as "0" is reserved for the NO\_DATA.

Level-1C products are resampled with a constant GSD (Ground Sampling Distance) of 10m, 20m and 60m according to the native resolution of the different spectral bands.

Input of Level-1C processing	Description
Metadata	Metadata from Level-1B
Image Data	Radiometrically and geometrically corrected image data
Ancillary Data	Ancillary data from the Level-1B (satellite and ground ancillary data, including the refined geometric model)
Auxiliary Data	GIIP: Parameters from Level-1B complemented by radiometric and geometric processing parameters
Quality Indicator Data	Quality Indicator files from Level-1B

Table 93: Input of Level-1C Processing

Note that one Level-1C product:

- refers always to one Datatake;
- refer to one or several Datastrip from the same Datatake;
- may cover the full Datatake or an extract of the Datatake.

In the case of an extract, the image data are provided to cover only the selected area.

By default, Level-1C is geometrically refined. Some Level-1C may not be geometrically refined (e.g. for Cal/Val purposes). These products are identified with a dedicated flag in the metadata.

The following figure gives an overview of the Level-1C User Product physical format. The yellow boxes correspond to folders and the white ones to files:

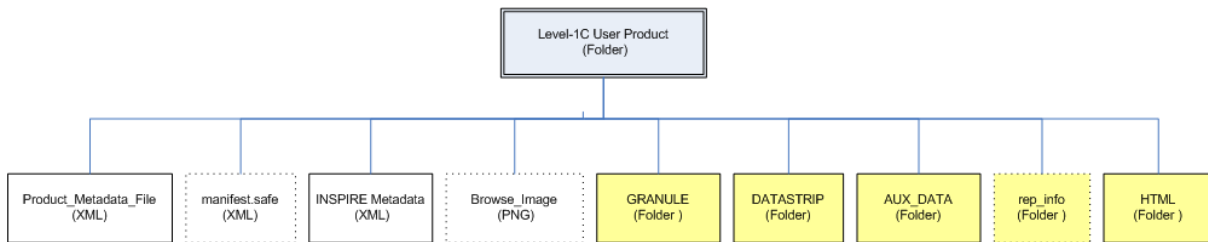

Figure 86: Level-1C User Product Structure

The Level-1C User product consists of:

1. **Product\_Metadata\_File**: mandatory XML main metadata file.
2. **manifest.safe**: SAFE metadata file (optional). It is included in the product only if the user requests the SAFE as output format (download option).
3. **GRANULE**: this folder (the name is chosen for homogeneity with respect to the other User Product but should be TILE) contains the tiles composing the product (Image Data). The Image Data corresponds to a set of Tiles containing one image file per band and the TCI corresponding to the coverage of the Tile itself. A sub-set of the 13 bands can be provided (download option).
4. **DATASTRIP**: folder containing the Datastrip composing the product linked to the selected tiles.
5. **AUX\_DATA**: folder containing, if requested by the user (download option), the GIPP files and IERS Bulletins used for the Level-1C User Product production. All Level-1C auxiliary data are referenced in the product metadata file. In addition, the Level-1C User Product embeds always at GRANULE (TILE) level an elementary set of meteorological datasets resampled ECMWF in tile geometry.
6. **Browse\_Image**: PNG file consisting of an image limited to 3 visible-bands in ground geometry at 320m resolution. This file, provided if requested by the user (download option), gives an overview of the product (sub-sampled) mainly for image data browsing and selection purposes,
7. **rep\_info**: folder containing the XSD schema provided inside the product. This folder is optional. It will be included in the User Product if the user selects the SAFE format as output format (cf. section 1.6.4).
8. **INSPIRE**: XML INSPIRE metadata file (cf. Annex B).
9. **HTML**: folder containing an HTML product presentation file (UserProduct\_index.html) and the corresponding stylesheet (UserProduct\_index.xsl).

#### 4.9.2 Image Data

The final projection of the product is **UTM** (over **WGS84**). The appropriate UTM zone will be selected according to each Tile of the product.

The image data is tiled in several elementary units. Each Tile is defined (with an appropriate GIPP file passed to the Level-1C processing chain), by:

- Its projection code (UTM code),
- Its anchorage point (ground coordinates of the upper-left pixel of the Tile),
- Pixel size in line and column,
- Tile size in number of lines and columns (rectangle)

This definition insures for all resolutions:

- upper-left corner is at the same location
- the number of pixels in the Tile is an integer

However, depending on the information inside the GIPP defining the Tiles, coverage of a Tile could be slightly different depending on the resolutions. Consequently, the lower-right corner could be at different locations depending on the resolutions.

The tiling definition shall ensure an overlap between tiles at the UTM zone borders.

A UTM tiling following the US-MGRS (US Military Grid Reference System) approach is proposed (100x100km<sup>2</sup>).

The tiling concept is illustrated on Figure 78 showing the standard **6° longitude x 8° latitude UTM zones divided into 100km x 100km tiles**.

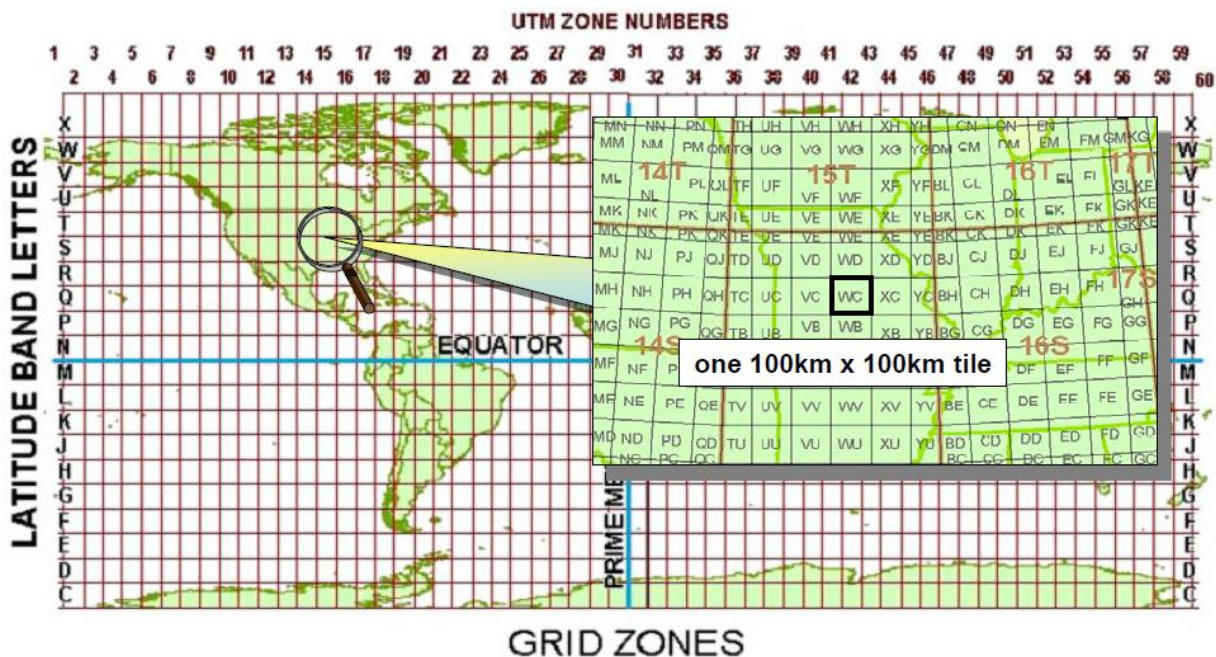

Figure 87: Level-1C Tiling Concept in UTM

Each Tile is then identified by 5 characters:

- The first two characters represent the 6° wide UTM zone.
  - Leading zeroes are included so that Zone 9 is “09”.
- The third character is a letter designating a band of latitude.

- Beginning at 80°S and proceeding northward, the 20 bands are lettered C through X, omitting I and O.
- The bands are all 8° high except band X, which is 12° high.
- The fourth and fifth characters are a pair of letters designating one of the 100,000-meter side grid squares inside the grid zone.

For example, in the previous figure, the black-squared Tile is identified 15SWC.

#### 4.9.2.1 Image Data Encoding and Files

The image data are provided as separated raster files for each spectral band (i.e. in total of 13 GML/JPEG2000 files per Tile plus one additional file for the TCI).

Each image file is compressed using the JPEG2000 algorithm. The parameters of the JPEG2000 compression are specified in the Annex G. The upper-left pixel corner coordinates of all bands shall have the same coordinates and shall be a multiple of 60m. For each file, the JPEG2000 header contains GML-JP2 information for ortho-image georeferencing. Each Tile is therefore georeferenced.

#### 4.9.3 Ancillary Data

The raw Satellite Ancillary Data are not embedded in the Level-1C User.

#### 4.9.4 Auxiliary Data

All Auxiliary Data used for Level-1C processing are referenced in the product metadata file.

The Level-1C auxiliary data (GIPPs and IERS bulletin) are provided with the product if requested by the user (download option).

In addition, the Level-1C User Product embeds always a GRANULE (TILE) level an elementary set of meteorological datasets extracted and resampled from ECMWF forecast output (cf. [ECMWF-FCAST]) and relevant to down-stream processing (e.g. atmospheric corrections).

The ECMWF auxiliary data embedded in the Level-1C at Tile level includes the following parameters:

- Total column ozone (TCO3) [Kg/m<sup>2</sup>];
- Total column water vapour (TCWV) [Kg/m<sup>2</sup>];
- Mean sea level pressure (MSL) [hPa].

Resulting from a temporal and spatial interpolation of the raw ECMWF global forecast dataset, this data will be provided as part of the Level-1C auxiliary data resampled and distributed in grid information tiles with the same dimensions as the Level-1C Tiles. Grid points are provided in latitude/longitude using WGS84 reference system.



## Sentinel-2 Products Specification Document

REF : S2-PDGS-TAS-DI-PSD

ISSUE : 14.5

DATE : 14/03/2018

PAGE : 414 / 510

They are interpolated from original ECMWF data to match L1C Tiles both temporally (linear) and geometrically (bilinear with a Ground Sample Distance of 12.5km) and provided in GRIB V1 format.



#### 4.9.5 Quality Indicators

Level-1C quality indicators are derived from Level-1B ones and are complemented by quality indicators relevant to the processing applied.

The *Product Level Quality Indicators* are provided at product level and referenced through the metadata file.

The *Tile Level Quality Indicators* are provided at Tile level in the standard structure of the metadata file.

The *Pixel Level Quality Indicators* are provided at Tile level through dedicated quality masks that provide quality information at pixel level. The Tile level metadata file (Standard structure) contains a pointer to the mask file.

There is one vector file for each type of mask and each Tile (or aggregation of tiles). Each vector mask file consists of a set of polygons defined in ground geometry: (X, Y) in the projected reference frame.

#### 4.9.6 Metadata

The following table shows the groups of metadata provided inside a Level-1C User Product:

Level-1C User Product Metadata	
<b>Product Level Metadata</b>	All product level metadata, specific for the User level, are consolidated/computed because not present at Granule and Datastrip level.
<b>Granule Level Metadata (Brief/Standard/Expertise)</b>	All Brief/Standard/Expertise metadata (download option, cf. section 4.4) defined at Granule level are copied from the input Granules to the User Product.
<b>DATASTRIP Level Metadata (Brief/Standard/Expertise)</b>	All Brief/Standard/Expertise metadata (download option, cf. section 4.4) defined at Datastrip level are copied from the input Datastrips to the User Product;

Table 94: Level-1C Product Metadata

As mentioned in the section 2.10, the User Product metadata (all) are not provided with a *metadataLevel* attribute (Brief/Standard/Expertise) unlike what happens for all Granule and Datastrip metadata.

During the User Product assembling, this attribute is used to select by filtering, according to a download option, the set of metadata that must be included in the User Product.

For these filtered fields, the *metadataLevel* attribute is not written in the User Product's metadata.

Note that an User Product for an expert user (Expertise download option) will contain all level of metadata (Brief/Standard/Expertise). An User Product for a user with "Standard" or "Brief" permission will contain only Brief/Standard or Brief metadata.

In addition to the metadata in the table above, the User Product contains the *manifest.safe* metadata (when the User Product is SAFE format) and the INSPIRE metadata.

The Level-1C Product Metadata are detailed in the section 4.9.7.



## 4.9.7 User Product Level-1C Structure

The *S2\_User\_Product\_Level-1C\_Structure.xsd* schema annexed to the document and shown in the following diagram, represents the structure of a S2 Level-1C User Product. This schema is provided for information only as It is actually not expected to be used for the validation of a XML file. The diagram reflects exactly the structure shown in the Figure 76.

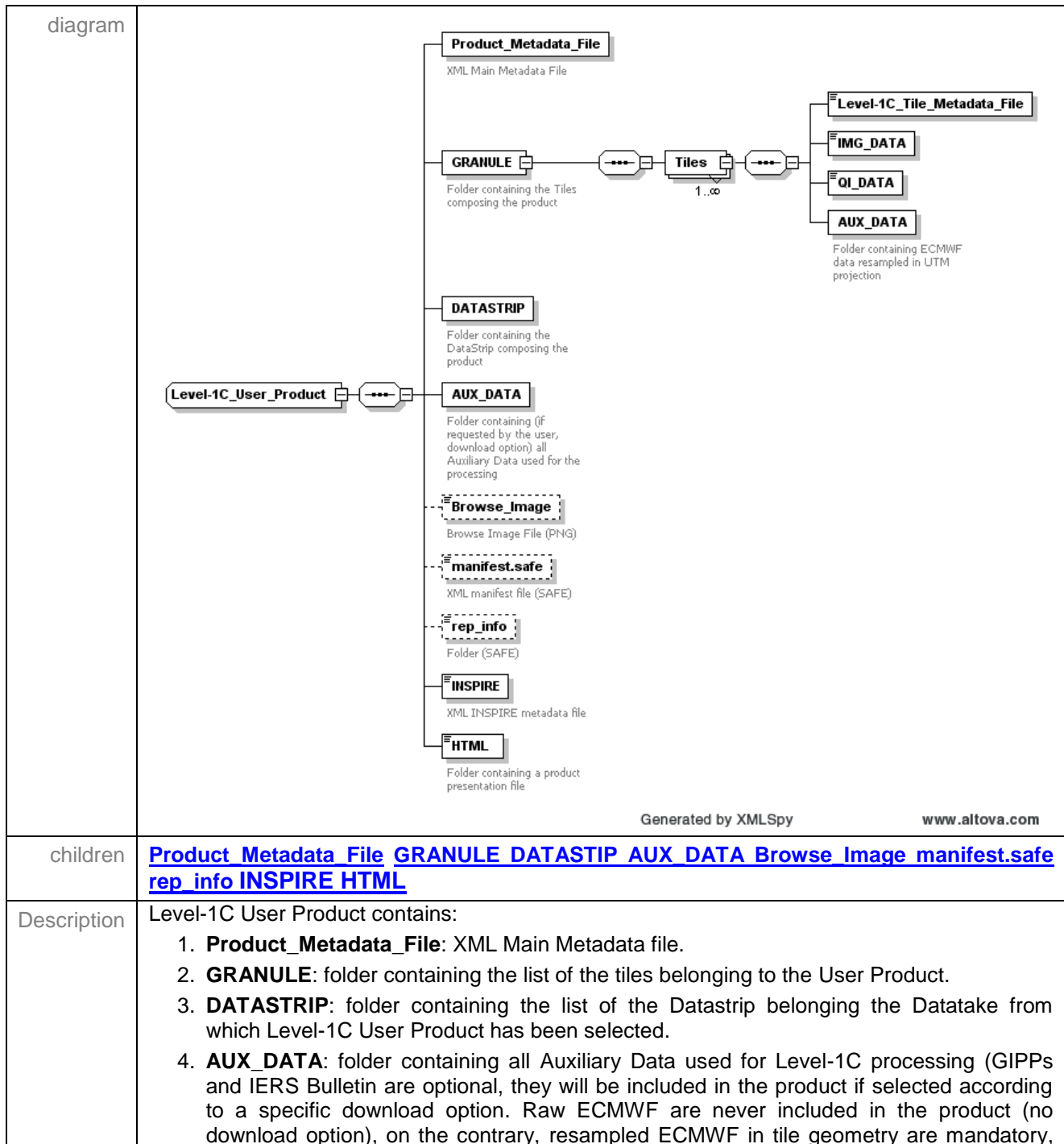

always embed in the product at GRANULE level.

5. **Browse\_Image**: PNG file for image data browsing and selection purposes.
6. **manifest.safe**: XML SAFE Manifest file
7. **rep\_info**: optional folder containing the XSD schema
8. **INSPIRE.xml**: XML INSPIRE metadata file
9. **HTML**: folder containing an HTML product presentation file and the corresponding stylesheet.

Note that the folder containing the tiles is named "GRANULE" to maintain the same naming used for L0/L1A/L1B products.

#### 4.9.7.1 Product\_Metadata\_File Schema

Product\_Metadata\_File is the XML metadata file provided inside the S2 Level-1C User Product. The XSD schema annexed to this document and used to validate it is *S2\_User\_Product\_Level-1C\_Metadata.xsd*.

A detailed description of the schema is given here but for specific details regarding each metadata (e.g. type, default value, fixed value, enumerations, occurrences, etc...) refers to the XSD file.

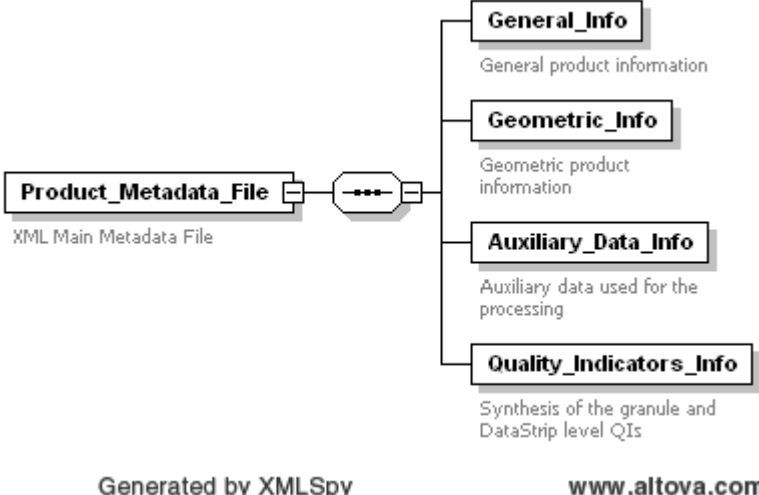
<p>diagram</p>	
<p>children</p>	<p><a href="#">General_Info</a> <a href="#">Geometric_Info</a> <a href="#">Auxiliary_Data_Info</a> <a href="#">Quality_Indicators_Info</a></p>
<p>Description</p>	<p>The Product_Metadata_File describes the product data items. It is presented to the user as a structured container of information. Product_Metadata_File is an XML file containing:</p> <ol style="list-style-type: none"> <li>1. <b>General_Info</b>: provides general product information.</li> <li>2. <b>Geometric_Info</b>: describing the geolocation over WGS84 of the contour of the product.</li> <li>3. <b>Auxiliary_Data_Info</b>: Links to the AUX_DATA items.</li> <li>4. <b>Quality_Indicators_Info</b>: Synthesis of the Granule and Datastrip level QIs.</li> </ol>

The following figures and tables give a complete description of the User Product metadata.

#### General\_Info:

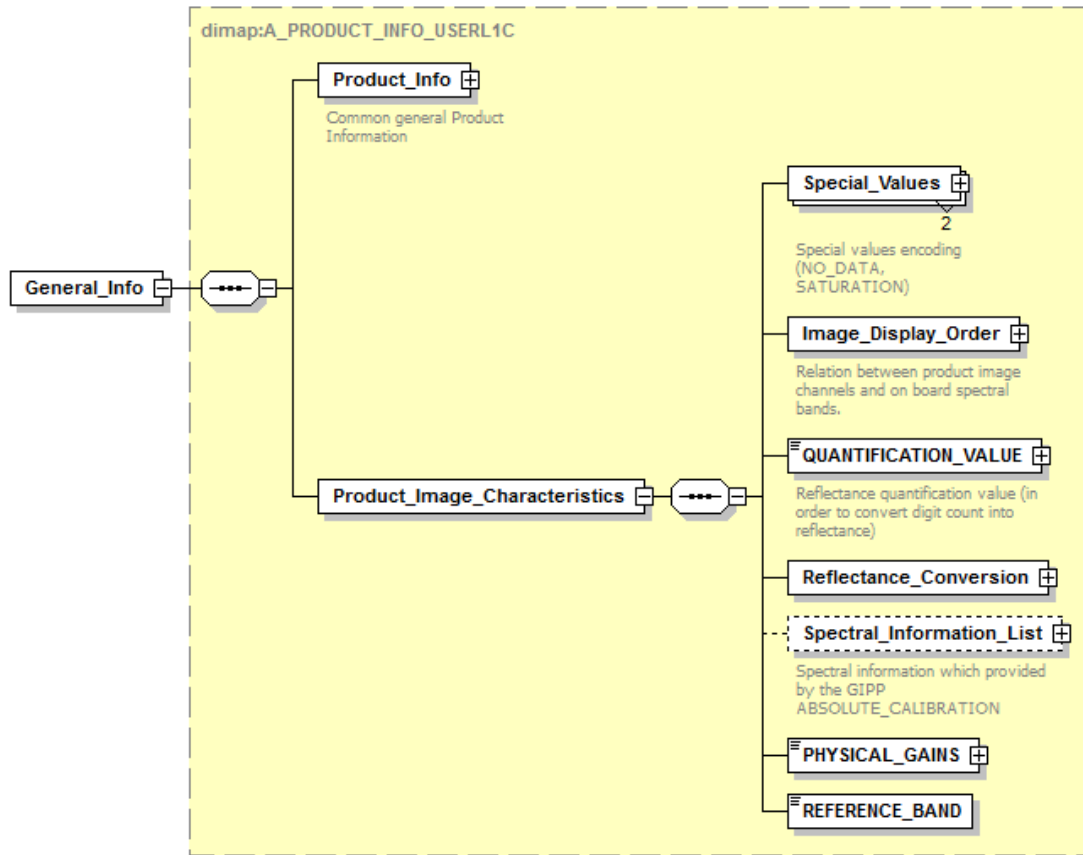

Generated by XMLSpy

www.altova.com

Figure 88 : Level-1C\_Product\_Metadata\_File - General\_Info Diagram



**Sentinel-2 Products  
Specification Document**

REF : S2-PDGS-TAS-DI-PSD  
 ISSUE : 14.5  
 DATE : 14/03/2018  
 PAGE : 421 / 510

General_Info		
Field Name	Description	Note
Product_Info	This group of metadata is described in the Table 79.	Cf. Table 79
Product_Image_Characteristics/Special_Values/SPECIAL_VALUE_TEXT Product_Image_Characteristics/Special_Values/SPECIAL_VALUE_INDEX	Cf. Table 87	Cf. Table 87
Product_Image_Characteristics/Image_Display_Order/RED_CHANNEL Product_Image_Characteristics/Image_Display_Order/GREEN_CHANNEL Product_Image_Characteristics/Image_Display_Order/BLUE_CHANNEL	Spectral bands (Relation between product image channels and on board spectral bands)	Information available at Datastrip level (cf. Table 3-59)
Product_Image_Characteristics/QUANTIFICATION_VALUE	Reflectance quantification value (in order to convert digit count into reflectance) and unit.	Information available at Datastrip level (cf. Table 3-59)
Product_Image_Characteristics/Reflectance_Conversion/U	Correction to take into account the Sun-Earth distance variation (this correction is computed using the acquisition date)	Information available at Datastrip level (cf. Table 3-59)
Product_Image_Characteristics/Reflectance_Conversion/Solar_Irradiance_List/SOLAR_IRRADIANCE	Reflectance parameters defined for each band	Information available at Datastrip level (cf. Table 3-59)
Product_Image_Characteristics/Spectral_Information_List/Spectral_Information/RESOLUTION Product_Image_Characteristics/Spectral_Information_List/Spectral_Information/Wavelength/MIN Product_Image_Characteristics/Spectral_Information_List/Spectral_Information/Wavelength/MAX Product_Image_Characteristics/Spectral_Information_List/Spectral_Information/Wavelength/CENTRAL Product_Image_Characteristics/Spectral_Information_List/Spectral_Information/Spectral_Response/STEP Product_Image_Characteristics/Spectral_Information_List/Spectral_Information/Spectral_Response/STEP	Spectral filter information provided by the GIPP ABSOLUTE_CALIBRATION	Information available at Datastrip level (cf. Table 3-56)
Product_Image_Characteristics/PHYSICAL_GAIN	Physical Gain for each band	Information available at Datastrip level
Product_Image_Characteristics/REFERENCE_BAND	Used Reference Band	Information available at Datastrip level

Table 95: Level-1C\_Product\_Metadata\_File - General\_Info Description





**Sentinel-2 Products  
Specification Document**

REF : S2-PDGS-TAS-DI-PSD  
ISSUE : 14.5  
DATE : 14/03/2018  
PAGE : 422 / 510



Geometric Info:

All geometric product information are described in the Table 4-10 except for *Geometric\_Header\_List* node not relevant for a Level-1C User Product.

Auxiliary Data Info:

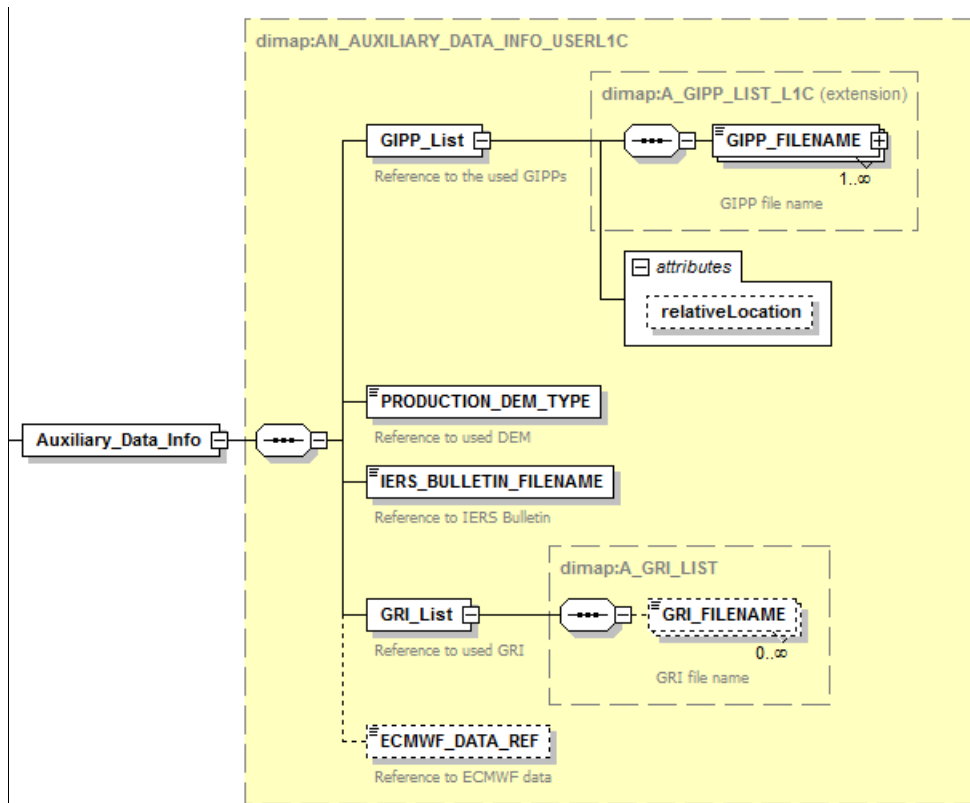

Figure 89 : Level-1C Product\_Metadata\_File – Auxiliary\_Data\_Info Diagram

Auxiliary Data Info		
Field Name	Description	Note
GIPP_FILENAME	Reference to the used GIPP files.	Available at Datastrip level
PRODUCTION_DEM_TYPE	Reference to the used DEM	Available at Datastrip level
IERS_BULLETIN_FILENAME	Reference to the used IERS Bulletin	Available at Datastrip level
GRI_FILENAME	Reference to the used GRI data	Available at Datastrip level
ECMWF_DATA_REF	Reference to the used ECMWF data	Available at Datastrip level

Table 96: Level-1C Product\_Metadata\_File - Auxiliary\_Info Description

Quality Indicators Info:

The Quality\_Indicators\_Info are described in the Table 82.

In addition the Level-1C User Product contains the RADIOMETRIC\_QUALITY check based on the OLQC reports contained in the Datastrips/QI\_DATA with RADIOMETRIC\_QUALITY checklist name.

RADIOMETRIC\_QUALITY check is FAILED if at least one report at Datastrip level is with *globalStatus* FAILED.

All OLQC checks performed on L1C Tiles/Datastrips and related to a specific checklist name (cf. Annex C), are in the Table 3-17 and Table 3-24.

#### 4.9.7.2 GRANULE

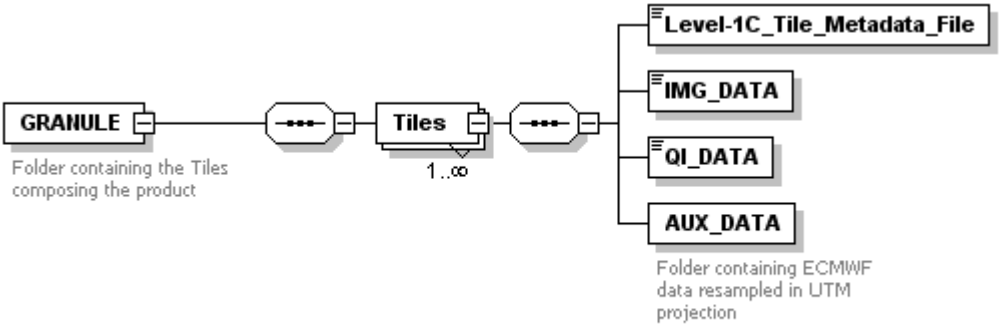
<p>diagram</p>	 <p align="center">Generated by XMLSpy <span style="float: right;">www.altova.com</span></p>
<p>annotation</p>	<p>Note: "GRANULE" name has been chosen for homogeneity with respect to the others User Product but should be TILE.</p> <p>GRANULE folder is a "folder of folders" each one corresponding to the Tiles composing the product and identified by proper PDI_ID (Tile ID).        The structure of each Tile included in the product is the same of the Level-1C Tile PDI described in the section 3.11.3 taking into account that:</p> <ol style="list-style-type: none"> <li>1. the Tile metadata are copied in the User Product as they are except for the <i>metadataLevel</i> attribute (Brief/Standard/Expertise) always set as empty string (cf. section 4.9.6),</li> <li>2. the XML <i>Level-1C_Tile_Metadata_File</i> is validated using the <i>S2_PDI_Level-1C_Tile_Metadata.xsd</i> schema annexed to the document,</li> <li>3. the <i>Inventory_Metadata.xml</i>, <i>manifest.safe</i> and <i>rep_info</i> are removed when the Tile PDI is included in the User Product (cf. section 3.11.3).</li> </ol>

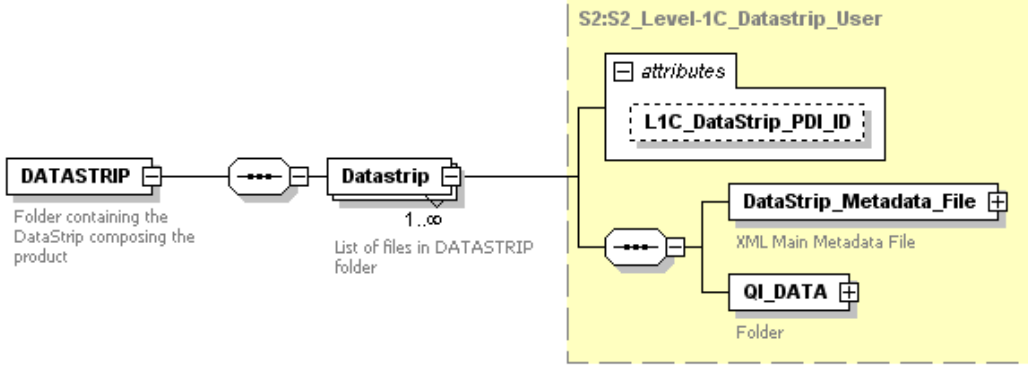

#### 4.9.7.3 DATASTRIP

<p>diagram</p>	 <p align="center">Generated by XMLSpy <span style="float:right">www.altova.com</span></p>
<p>annotation</p>	<p>DATASTRIP folder is a “folder of folders” each one corresponding to the Datastrip composing the product and identified by proper PDI_ID (Datastrip_ID). The structure of each Datastrip included in the product is the same of the Level-1A Datastrip PDI described in the section 3.13.3 taking into account that:</p> <ol style="list-style-type: none"> <li>1. the Datastrips metadata are copied in the User Product as they are except for the <i>metadataLevel</i> attribute (Brief/Standard/Expertise) always set as empty string (cf. section 4.9.6),</li> <li>2. the XML Datastrip_Metadata_File is validated using the <i>S2_PDI_Level-1C_Datastrip_Metadata.xsd</i> schema annexed to the document,</li> <li>3. <i>Inventory_Metadata.xml</i>, <i>manifest.safe</i> and <i>rep_info</i> are removed when the Datastrip PDI is included in the User Product (cf. section 3.13.3).</li> </ol>

#### 4.9.7.4 AUX\_DATA

<p>diagram</p>	 <p align="center">Generated by XMLSpy <span style="float:right">www.altova.com</span></p>
<p>annotation</p>	<p>All Auxiliary Data used for Level-1C processing are referenced through the Product_Metadata_File. GIPP files and IERS Bulletin are included in the product if requested by the user (download option).</p> <p>In addition, ECMWF auxiliary data (resampled in UTM projection) are mandatory and always embedded in the Level-1C User Product at tile level (within the ANX_DATA folder defined at GRANULE level).</p>

#### 4.9.7.5 Browse\_Image

diagram	
annotation	<p>Browse Image in PNG format. The Browse Image is included in the User Product if required by the user (download option). This Browse Image is based on the PVI extracted from the Level-1C Tile PDI (JPEG2000 low resolution extraction, 3 visible-bands in ground geometry at 320m resolution, RGB). The final geometric representation of the preview is defined by the user according to its region of interest (either geographic or cartographic representation).</p>

#### 4.9.8 Tiles Consolidation

Two adjacent Tiles of the same Datatake but at the edge of two consecutive Datastrips have to be “consolidated” to create a complete one.

During the UTM Tile consolidation processing, the image part of 2 uncompleted and complementary Tiles are merged together.

Consolidation shall be performed on metadata too, based on the metadata of the 2 source tiles.

Tile consolidation process is applied to TCI too.

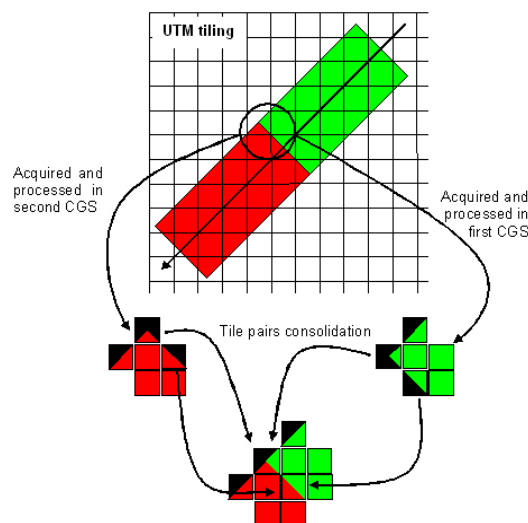

Figure 90: Tile pairs consolidation

If the Tile Consolidation option is activated in parallel with the *Single Tile Product Packaging* download option, the Tile consolidation process shall be performed prior to the Level-1C Single Tile User Products generation. In this way each Single Tile User Products shall contain each one a single consolidated Tile.

##### 4.9.8.1 Tiles Consolidated ID

The Tile ID of a Tile consolidated resulting from a merging of the two uncompleted Tiles is the same described in the section 3.4.2 with file type **MSI\_L1C\_CO**:

PDI\_ID = MMM\_CCCC\_TTTTTTTTTT\_<Instance\_ID>

Where:

<Instance\_Id> = <Site Centre>\_<Creation Date>\_<Absolute Orbit>\_<Tile>\_<Processing Baseline>

Template name:

S2A\_OPER\_MSI\_L1C\_CO\_EPA\_20141104T134012\_A012345\_T15SWC\_N01.01.tar

The physical organization (file system) of incomplete and complete Tiles is the same as described in the section 3.11.

Note that the merging of uncompleted Tiles is a download option that can be selected by the user (cf. Section 4.4). If this option is selected, then the User Product contains only completed tiles (which includes merged tiles, that is the user does not receive uncompleted tiles).

#### 4.9.8.2 Metadata of a Consolidated Tile

All the metadata describing a consolidated Tile are the same of the ones described in the Section 3.11.3.1.

General_Info		
Field Name	Tile	Tile Consolidated
TILE_ID	TILE identifier (PDI_ID) defined in section 3.11.1	Tile ID defined above
DATASTRIP_ID	Identifier of the Datastrip containing the Tile	As the two uncompleted Tiles are on two Datastrip, this metadata contains two different Datastrip Identifiers
DOWNLINK_PRIORITY	Downlink priority flag. It can be set Nominal/NRT/RT	Downlink priority flag. It can be set Nominal/NRT/RT
SENSING_TIME	TILE Start Time. This value is currently set to the Datastrip Start Time (cf. datastrip definition in section 2.3)  Note: set as Type date_time:AN_UTC_DATE_TIME	As the two uncompleted Tiles are on two Datastrip, this metadata contains two different Datastrip Start Time
Archiving_Info/ARCHIVING_CENTRE	The starting point of the circulation data. The allowed values are: <ul style="list-style-type: none"> <li>• SGS_</li> <li>• MPS_</li> <li>• MTI_</li> <li>• EPA_</li> <li>• UPA_</li> <li>• CDAM</li> <li>• MPC_</li> </ul>	"EPA_" assigned to Spanish PAC
Archiving_Info/ARCHIVING_TIME	Processing/archiving date (UTC data time)	Processing/archiving date (UTC data time)
Geometric_Info		

Field Name	Tile	Tile Consolidated
Tile_Geocoding/HORIZONTAL_CS_NAME	Name of horizontal coordinate reference system	Name of horizontal coordinate reference system
Tile_Geocoding/HORIZONTAL_CS_CODE	Code of horizontal coordinate reference system	Code of horizontal coordinate reference system
Tile_Geocoding/Size	Tile dimensions for each resolution band	Tile dimensions for each resolution band
Tile_Geocoding/Geoposition	XDIM and YDIM for each resolution band	XDIM and YDIM for each resolution band
Tile_Angles/Sun_Angles_Grid	Grid of sun angles (zenith and azimuth) and the correction which takes into account earth-sun distance variation and for each band sun equivalent irradiance	Grid of sun angles (zenith and azimuth) and the correction which takes into account earth-sun distance variation and for each band sun equivalent irradiance
Tile_Angles/Mean_Sun_Angle	Mean value containing sun zenith and azimuth angle average for all bands and detectors	Mean value containing sun zenith and azimuth angle average for all bands and detectors
Tile_Angles/Mean_Incidence_Angle	List of mean values containing viewing incidence zenith and azimuth angle average for each band and for all detectors	List of mean values containing viewing incidence zenith and azimuth angle average for each band and for all detectors
Tile_Angles/Viewing_Incidence_Angles_Grids	Grid of incidence angles (zenith and azimuth) (per bands and detectors)	Grid of incidence angles (zenith and azimuth) (per bands and detectors)
<b>Quality Indicators Info</b>		
Field Name	Tile	Tile Consolidated
CLOUDY_PIXEL_PERCENTAGE	Percentage of the cloud coverage	Average of cloud coverage percentages computed for each uncompleted Tile
DEGRADED_MSI_DATA_PERCENTAGE	Percentage of degraded MSI data	Average of the percentages of degraded MSI data computed for each uncompleted Tile
Pixel_Level_QI/MASK_FILENAME	Pointer to the mask files contained in the QI_DATA folder: - Finer cloud mask files	Pointer to the consolidated mask files contained in the



## Sentinel-2 Products Specification Document

REF : S2-PDGS-TAS-DI-PSD  
ISSUE : 14.5  
DATE : 14/03/2018  
PAGE : 430 / 510

	<ul style="list-style-type: none"><li>- Technical quality mask files</li><li>- Detector footprint mask</li><li>- Radiometric quality masks</li></ul>	QI_DATA folder of the consolidated Tile
Pixel_Level_QI/PVI_FILENAME	Reference to PVI contained in the QI_DATA folder	Reference to PVI contained in QI_DATA folder of the consolidated Tile



#### 4.9.9 User Product Level-1C SAFE Manifest synoptic table

The final User Product contains only one main *manifest.safe* file. The *manifest.safe* files related to each Granules/Datastrips composing the product are available at PDI level but they are not included in the User Product, all lower level PDI are removed.

This chapter provides a detailed description of the content of the SAFE Manifest for the Level-1C User Product, including a synoptic table with the list of the metadata information to be included in the SAFE Manifest.

The structure of the Manifest is based on the Level-1C Manifests provided for Tiles and Datastrip (cf. sections 3.11.4 and 3.12.4).

Same considerations as in section 4.6.8 **apply** for what concerns compliancy to SAFE specification [SAFE-SPEC] and content of synoptic tables (except for the Data Objects Section that does not contain an ANC\_DATA folder).

A practical example of Manifest file for the Level-1C User Product is provided as annexed zip file to this document (S2-PDGS-TAS-DI-PSD-V14\_SAFE.zip).

SAFE Manifest		Corresponding metadata in the S2_User_Product_Level-1C_Metadata.xsd	Description	Data Type	Occurrence	Allowed range of values
Metadata name	Name of tag or attribute (in bold)	Tag name				
platform						
	nssdcIdentifier	N.A.	Unique identifier of the platform, defined by the World Data center for Satellite Information (WDC-SI)		1	WDC is discontinued; this tag is set to a default value 0000-0000
	familyName	Level-1C_User_Product->General_Info->Product_Info->Datatake->SPACECRAFT_NAME	The mission name of the platform	string enum	0..1	Sentinel
	number	Level-1C_User_Product->General_Info->Product_Info->Datatake->SPACECRAFT_NAME	Sequence identifier of the platform among the mission	string enum	0..1	2A, 2B, 2C
	instrument->familyName	N.A.	The instrument name used for acquiring the product data	string enum	0..1	Multi-Spectral Instrument
	instrument-> <b>abbreviation</b>	N.A.	Abbreviation of the instrument name	string enum	0..1	MSI
	instrument->mode	Level-1C_User_Product->General_Info->Product_info->Datatake->DATATAKE_TYPE	The mode of the instrument	string enum	0..1	Nominal_Observation Dark_Signal_Calibration Extended_Observation Absolute_Radiometry_Calibration Vicarious_Calibration Raw_Measurement Test_Mode





## Sentinel-2 Products Specification Document

REF : S2-PDGS-TAS-DI-PSD  
 ISSUE : 14.5  
 DATE : 14/03/2018  
 PAGE : 433 / 510

SAFE Manifest		Corresponding metadata in the S2_User_Product_Level-1C_Metadata.xsd	Description	Data Type	Occurrence	Allowed range of values
Metadata name	Name of tag or attribute (in bold)	Tag name				
	instrument->mode-> <b>identifier</b>	Level-1C_User_Product->General_Info-> Product_info->Datatake->DATATAKE_TYPE	The identifier of the instrument mode	string enum	1	INS-NOBS INS-EOBS INS-DASC INS-ABSR INS-VIC INS-RAW INS-TST
processing			Textual description of the history of processings that lead to the current product and of all the relevant resources involved in the processing (facilities, software, applicable documents etc)		1	
	<b>name</b>		Name of the L1B to L1C Processing	string	0..1	Generation of L1C User Product
	<b>start</b>	Level-1C_User_Product->General_Info->Product_info->GENERATION_TIME	Processing start date (UTC)	xs:dateTime	0..1	
	<b>stop</b>	N.A.	Processing stop date (UTC)	xs:dateTime	0..1	
	facility	N.A.	Description of Processing Centre		0..*	
	facility-> <b>name</b>	N.A.	Extended name of Origin Centre	string	1	
	facility-> <b>organization</b>	N.A.	Organization to which the Origin center belongs	string	0..1	



SAFE Manifest		Corresponding metadata in the S2_User_Product_Level-1C_Metadata.xsd	Description	Data Type	Occurrence	Allowed range of values
Metadata name	Name of tag or attribute (in bold)	Tag name				
	facility-> <b>site</b>	Level-1C_User_Product->GRANULE->General_Info->GRANULE_ID (substring <Site Centre>, cf. section 3.11.1)	Acronym of the Processing center	string enum	0..1	SGS_ MPS_ MTI_ EPA_ MPC_ UPA_ XXXX EDRS zzzL (zzz = first three characters of the LGS location)
	facility-> <b>country</b>	N.A.	Country where Origin Centre is located	string	0..1	
	facility->software	N.A.	Description of software component used for Processing		0..*	
	facility->software-> <b>name</b>	N.A.	Name of the software component	string	1	
	facility->software-> <b>version</b>	N.A.	Version of the software component	string	0..1	
	resource		List of auxiliary data files used by the processors to support radiometric and geometric correction (GIPP, DEM, GRI, IERS Bulletin etc.) and of SAD Raw Data file containing the satellite ancillary telemetry;		0..*	



## Sentinel-2 Products Specification Document

REF : S2-PDGS-TAS-DI-PSD  
 ISSUE : 14.5  
 DATE : 14/03/2018  
 PAGE : 435 / 510

SAFE Manifest		Corresponding metadata in the S2_User_Product_Level-1C_Metadata.xsd	Description	Data Type	Occurrence	Allowed range of values
Metadata name	Name of tag or attribute (in bold)	Tag name				
			these files are provided with the product.			
	resource-> <b>name</b>	Level-1C_User_Product->DATASTRIP->Satellite_Ancillary_Data_Info->ANC_DATA_REF (reference to the folder containing the SAD Raw Data files)  Level-1C_User_Product->DATASTRIP->Auxiliary_Data_Info->IERS_Bulletin  Level-1C_User_Product->DATASTRIP->Auxiliary_Data_Info->GIPP_List->GIPP_FILENAME	Name of the auxiliary or ancillary files/folders needed for the Processing	string	1	
	resource-> <b>role</b>	N.A.	Role of the resource	string	1	Auxiliary data, Ancillary data
acquisitionPeriod					1	
	acquisitionPeriod -> start <b>Time</b>	Level-1C_User_Product->General_Info->Product_Info->Datatake->DATATAKE_SENSING_START	Reference time of acquisition of the product	xs:dateTime	1	
measurementFrameSet					1	
	footPrint	Derived from Level-1C_User_Product->Geometric_Info->Product_Footprint->Product_Footprint	Product footprint (namely imaged landscape corresponding to the whole product)	string (gml:linearRingType namely blank separated list of comma-separated long/lat coordinates of footprint closed polygon with last	0..1	





**Sentinel-2 Products  
Specification Document**

REF : S2-PDGS-TAS-DI-PSD  
 ISSUE : 14.5  
 DATE : 14/03/2018  
 PAGE : 436 / 510

SAFE Manifest		Corresponding metadata in the S2_User_Product_Level-1C_Metadata.xsd	Description	Data Type	Occurrence	Allowed range of values
Metadata name	Name of tag or attribute (in bold)	Tag name				
				vertex equal to first)		
measurementOrbitReference						
	orbitNumber	Level-1C_User_Product->General_Info->Product_Info->Datatake->DatatakeIdentifier (substring <AbsoluteOrbitNumber>)	Absolute orbit number		0..1	> 0
	orbitNumber->type	N.A.	Absolute orbit number type (possible values "start" or "stop"). Set to "start" since the absolute orbit number refers to the first line of the first Granule of the User Product		0..1	start
	orbitNumber->groundTrackDirection	Level-1C_User_Product->General_Info->Product_Info->Datatake->SENSING_ORBIT_DIRECTION	Direction of the ground track of the Sentinel-2 platform at the time corresponding to orbitNumber->type (start or stop)		0..1	ascending, descending
	relativeOrbitNumber	Level-1C_User_Product->General_Info->Product_Info->Datatake->SENSING_ORBIT_NUMBER	Relative orbit number (within the cycle)		0..1	1 to 143
	relativeOrbitNumber->type	N.A.	Relative orbit number type (possible values "start" or "stop"). Set to "start" since the absolute orbit number refers to the first line of		0..1	start



SAFE Manifest		Corresponding metadata in the S2_User_Product_Level-1C_Metadata.xsd	Description	Data Type	Occurrence	Allowed range of values
Metadata name	Name of tag or attribute (in bold)	Tag name				
			the Datastrip			
metadataComponents		Level-1C_User_Product->DATASTRIP Satellite_Ancillary_Data_Info->ANC_DATA_REF (reference to the folder containing the SAD Raw Data files)  Level-1C_User_Product->DATASTRIP-> Auxiliary_Data_Info->IERS_Bulletin  Level-1C_User_Product->DATASTRIP-> Auxiliary_Data_Info->GIPP_List->GIPP_FILENAME	A reference to all ancillary/auxiliary Metadata files/folders included in the product (e.g. the XML Metadata file, the INSPIRE Metadata file, the Auxiliary Data files) or external to the product (the Ancillary Data files)		1..*	
metadataComponentSchemas		N.A	A reference to the Schemas used to validate the Metadata files included in the product (e.g. the XML Metadata file Schema)		0..1	

Table 97- Content of Metadata section for Level-1C User Product SAFE Manifest

#### 4.9.10 Compact Naming Convention for L1C

This section contains the rules applied to define the compact naming convention for a Level-1C User Product. Based on the standard User Product naming convention described in the section 4.2, the rules in the following table are described.

Notice that some metadata changes to keep the product coherency and navigation capabilities.

Level-1C User Product Components	Compact Naming Rules
<p><b>Product Name Root Directory</b></p>	<p>The <b>Product Name Root</b> Directory follows this naming convention:</p> <p>MMM_MSIL1C_ YYYYMMDDTHHMMSS_Nxxyy_Rooo_&lt;Product Discriminator&gt;.SAFE</p> <p>where:</p> <ul style="list-style-type: none"> <li>• <i>MMM</i> is the mission identifiers S2A / S2B</li> <li>• <i>MSIL1C</i> is the fixed string to identify Level-1C products</li> <li>• <i>YYYYMMDDTHHMMSS</i>: is the <i>Datatake</i> sensing time</li> <li>• <i>Nxxyy</i> is the production baseline (e.g. N0201)</li> <li>• <i>Rooo</i> is the relative orbit number (e.g. R101)</li> <li>• <i>&lt;Product Discriminator&gt;</i> is a 15-characters string discriminator to distinguish different end user products associated to the same datatake</li> </ul> <p>Example below:</p> <p>S2A_MSIL1C_20150802T105414_N0102_R008_20150803T124046.SAFE</p>
<p><b>Product_Metadata_File</b></p>	<p>MTD_MSIL1C.xml</p>
<p><b>manifest.safe</b></p>	<p>None</p>

**Level-1C User Product  
Components**

**Compact Naming Rules**

**GRANULE**

1. Each **Tile folder name** follows the naming convention:

L1C\_Txxxxx\_Azzzzzz\_<tile discriminator>

where:

- <tile\_discriminator>: is a 15-characters string discriminator to distinguish between partial tiles generated out of the same datatake
- zzzzzz: is the Absolute Orbit Number
- xxxxx: is the Tile ID according to US-MGRS naming convention

2. The **Tile Metadata** filename is *MTD\_TL.xml*

3. The **Image File name** of the tiles follows this naming convention:

Txxxxx\_YYYYMMDDTHHMMSS\_Byy.jp2

where:

- YYYYMMDDTHHMMSS: is the *Datatake* sensing time
- xxxxxx: is the Tile ID according to US-MGRS naming convention
- yy: is the band index (01, 02, 03, 04, 05, 06, 07, 08, 8A, 09, 10, 11, 12)

Accordingly, the **TCl as a band filename** is harmonised with the tile images above defined:

Txxxxx\_YYYYMMDDTHHMMSS\_TCl.jp2

where:

- YYYYMMDDTHHMMSS: is the *Datatake* start sensing time
- xxxxxx: is the Tile ID according to US-MGRS naming convention

**Level-1C User Product  
Components**

**Compact Naming Rules**

4. The **PVI filename** is harmonised to the tile above defined:

Txxxxx\_YYYYMMDDTHHMMSS\_PVI.jp2

where:

- YYYYMMDDTHHMMSS: is the Datatake start sensing time
- xxxxxx: is the Tile ID according to US-MGRS naming convention

5. The **Masks filename** follows the naming convention:

TTTTTTTTTT\_Byy.gml

where:

TTTTTTTTTT =

- MSK\_CLOUDS (Finer cloud mask files)
- MSK\_TECQUA (Technical quality mask files)
- MSK\_DETFOO (Detector footprint mask files)
- MSK\_DEFECT (Radiometric quality masks)
- MSK\_SATURA (Radiometric quality masks)
- MSK\_NODATA (Radiometric quality masks)

6. The **OLQC report** filename follows the naming convention:

<checklistname>.xml

where <checklistname>=

- SENSOR\_QUALITY
- GEOMETRIC\_QUALITY
- GENERAL\_QUALITY
- FORMAT\_CORRECTNESS



Level-1C User Product Components	Compact Naming Rules
	<p>7. The <b>ECMWF auxiliary</b> data filename is <i>AUX_ECMWFT</i></p>
<p><b>DATASTRIP</b></p>	<p>1. The datastrip directory name follows the naming convention</p> <p><i>DS_ssss_yyyymmddThhmmss_S YYYYMMDDTHHMSS</i></p> <p>Where:</p> <ul style="list-style-type: none"> <li>• ssss is the Site Centre of the file originator</li> <li>• yyyymmddThhmmss is the creation date</li> <li>• YYYYMMDDTHHMSS is the datastrip sensing start time</li> </ul> <p><i>DS_SGS_20150802T122135_S20150802T105331</i></p> <p>2. The Datastrip Metadata filename is <i>MTD_DS.xml</i></p> <p>3. The <b>OLQC report</b> filename is compacted to refer only to the checklistname:</p> <p><i>&lt;checklistname&gt;.xml</i></p> <p>where <i>&lt;checklistname&gt;=</i></p> <p>SENSOR_QUALITY GEOMETRIC_QUALITY GENERAL_QUALITY RADIOMETRIC_QUALITY FORMAT_CORRECTNESS</p>
<p><b>AUX_DATA</b></p>	<p>1. The <b>IERS auxiliary</b> data filename is <i>AUX_UT1UTC.txt</i></p>



## Sentinel-2 Products Specification Document

REF : S2-PDGS-TAS-DI-PSD  
ISSUE : 14.5  
DATE : 14/03/2018  
PAGE : 442 / 510

Level-1C User Product Components	Compact Naming Rules
	2. The GIPP files are physically grouped altogether into tar file named <i>GIPP.tar</i>
<b>Browse_Image</b>	The <b>Browse Image</b> filename is <File-Type>.png : BWI_MSIL1C.png
<b>rep_info</b>	None
<b>INSPIRE</b>	None
<b>HTML</b>	None



In the following examples of Level-1C products tree with the standard naming convention and the corresponding compact naming convention are shown for better understanding of the differences.

Level-1C User Product tree defined using the Standard Naming Convention:

S2A\_OPER\_PRD\_MSIL1C\_PDMC\_20160615T141550\_R121\_V20160615T082012\_20160615T083135.SAFE

└─AUX\_DATA

| └─S2A\_OPER\_GIP\_BLINDP\_MPC\_\_20150605T094736\_V20150622T000000\_21000101T000000\_B00.TGZ

| └─....

| └─S2A\_OPER\_GIP\_VIEDIR\_MPC\_\_20151117T131051\_V20150703T000000\_21000101T000000\_B12.TGZ

| └─S2\_\_OPER\_AUX\_UT1UTC\_PDMC\_20160609T000000\_V20160610T000000\_20170609T000000.txt

└─DATASTRIP

| └─S2A\_OPER\_MSI\_L1C\_DS\_MTI\_\_20160615T115939\_S20160615T083135\_N02.04

| └─QI\_DATA

| └─S2A\_OPER\_MTD\_L1C\_DS\_MTI\_\_20160615T115939\_S20160615T083135.xml

└─GRANULE

| └─S2A\_OPER\_MSI\_L1C\_TL\_MTI\_\_20160615T115939\_A005123\_T36RVT\_N02.04





## Sentinel-2 Products Specification Document

REF : S2-PDGS-TAS-DI-PSD  
ISSUE : 14.5  
DATE : 14/03/2018  
PAGE : 444 / 510

```
|| └─AUX_DATA  
  
|| └─S2A_OPER_AUX_ECMWFT_MTI__20160615T115939_V20160615T060000_20160615T180000  
  
|| └─IMG_DATA  
  
|| └─S2A_OPER_MSI_L1C_TL_MTI__20160615T115939_A005123_T36RVT_B01.jp2  
|| └─S2A_OPER_MSI_L1C_TL_MTI__20160615T115939_A005123_T36RVT_TCI.jp2  
  
|| └─....  
  
|| └─QI_DATA  
  
|| └─S2A_OPER_MSK_CLOUDS_MTI__20160615T115939_A005123_T36RVT_B00_MSIL1C.gml  
  
|| └─....  
  
|| └─S2A_OPER_PVI_L1C_TL_MTI__20160615T115939_A005123_T36RVT.jp2  
  
|| └─S2A_OPER_MTD_L1C_TL_MTI__20160615T115939_A005123_T36RVT.xml  
  
| └─S2A_OPER_MSI_L1C_TL_MTI__20160615T115939_A005123_T36RVU_N02.04  
  
|| └─AUX_DATA  
  
|| └─S2A_OPER_AUX_ECMWFT_MTI__20160615T115939_V20160615T060000_20160615T180000  
  
|| └─IMG_DATA
```





## Sentinel-2 Products Specification Document

REF : S2-PDGS-TAS-DI-PSD  
ISSUE : 14.5  
DATE : 14/03/2018  
PAGE : 445 / 510

||| |—S2A\_OPER\_MSI\_L1C\_TL\_MTI\_\_20160615T115939\_A005123\_T36RVU\_B01.jp2  
||| |—...  
|| |—QI\_DATA  
||| |—S2A\_OPER\_MSK\_CLOUDS\_MTI\_\_20160615T115939\_A005123\_T36RVU\_B00\_MSIL1C.gml  
||| |—...  
|| |—S2A\_OPER\_PVI\_L1C\_TL\_MTI\_\_20160615T115939\_A005123\_T36RVU.jp2  
|| |—S2A\_OPER\_MTD\_L1C\_TL\_MTI\_\_20160615T115939\_A005123\_T36RVU.xml  
|—HTML  
| |—banner\_1.png  
| |—banner\_2.png  
| |—banner\_3.png  
| |—star\_bg.jpg  
| |—UserProduct\_index.html  
| |—UserProduct\_index.xsl





## Sentinel-2 Products Specification Document

REF : S2-PDGS-TAS-DI-PSD  
ISSUE : 14.5  
DATE : 14/03/2018  
PAGE : 446 / 510

|—INSPIRE.xml

|—manifest.safe

|—rep\_info

|—S2\_User\_Product\_Level-1C\_Metadata.xsd

|—S2A\_OPER\_MTD\_SAFL1C\_PDMC\_20160615T141550\_R121\_V20160615T082012\_20160615T083135.xml

|—S2A\_OPER\_BWI\_MSIL1C\_PDMC\_20130424T120700\_R054\_V20091210235100\_20091210235134.png





## Sentinel-2 Products Specification Document

REF : S2-PDGS-TAS-DI-PSD  
ISSUE : 14.5  
DATE : 14/03/2018  
PAGE : 447 / 510

Level-1C User Product tree defined using the Compact Naming Convention:

S2A\_MSIL1C\_20150802T105414\_N0102\_R008\_20150803T124046.SAFE

|—AUX\_DATA

| |—GIPP.tar

| |—AUX\_UT1UTC.txt

|—DATASTRIP

| |—DS\_SGS\_20150802T122135\_S20150802T105331

| | |—QI\_DATA

| | |—MTD\_DS.xml

|—GRANULE

| |—L1C\_T36RVT\_A005123\_20160615T115939

| | |—AUX\_DATA

| | | |—AUX\_ECMWFT

| | |—IMG\_DATA





## Sentinel-2 Products Specification Document

REF : S2-PDGS-TAS-DI-PSD  
ISSUE : 14.5  
DATE : 14/03/2018  
PAGE : 448 / 510

||| |— T36RVT\_20160615T115939\_B01.jp2  
||| |— T30RWQ\_20150802T122135\_TCI.jp2

||| |—....

|| |—QI\_DATA

||| |—MSK\_CLOUDS\_B00.gml

||| |—....

||| |— T36RVT\_20160615T115939\_PVI.jp2

|| |—MTD\_TL.xml

| |—L1C\_T36RVU\_A005123\_20160615T115939

|| |—AUX\_DATA

||| |—AUX\_ECMWFT

|| |—IMG\_DATA

||| |— T36RVU\_20160615T115939\_B01.jp2

||| |— T30RWQ\_20150802T122135\_TCI.jp2

||| |—....







## Sentinel-2 Products Specification Document

REF : S2-PDGS-TAS-DI-PSD  
ISSUE : 14.5  
DATE : 14/03/2018  
PAGE : 449 / 510

- || |—QI\_DATA
- || | |—MSK\_CLOUDS\_B00.gml
- || | |—....
- || | |— T36RVU\_20160615T115939\_PVI.jp2
- || |—MTD\_TL.xml
- |—HTML
- | |—banner\_1.png
- | |—banner\_2.png
- | |—banner\_3.png
- | |—star\_bg.jpg
- | |—UserProduct\_index.html
- | |—UserProduct\_index.xsl
- |—INSPIRE.xml
- |—manifest.safe



└─ rep\_info

| └─ S2\_User\_Product\_Level-1C\_Metadata.xsd

└─ MTD\_MSIL1C.xml

└─ BWI\_MSIL1C.png

#### 4.9.11 Single Tile User Product

The Level-1C Single Tile User Product is a download option applicable to the Level-1C User Product (*Single Tile Product Packaging* download option).

The Level-1C Single Tile User Product format is based on the Level-1C Used Product format defined in the section 4.9. For each Tile composing the Level-1C User Product a separate set of self-standing and fully consistent Level-1C Single Tile User-Products are generated covering one single Tile.



Figure 91: Level-1C User Product decomposition

The Level-1C Single Tile User Product physical format is the same defined in the section 4.9 and reported hereafter. In this case (*Single Tile Product Packaging* download option set to TRUE) the **GRANULE** folder contains one single Tile (one image file per band).



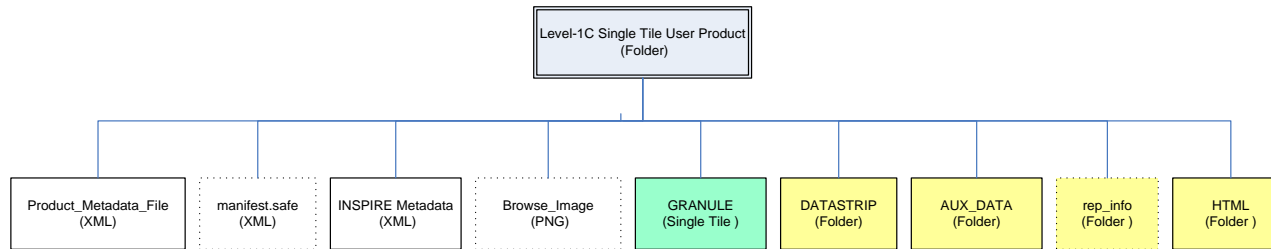

Figure 92: Level-1C Single Tile User Product Physical Format

The Level-1C Single Tile package output format shall be comply with the output format selected as download option for the Level-1C User Product (DIMAP,SAFE, SAFE\_COMPACT); in other words, if the Level-1C User Product is requested via download option in SAFE format, the related Level-1C Single Tile products shall be generated in SAFE format as well.

#### 4.9.11.1 Single Tile Naming Convention

The Level-1C Single Tile product name follows this naming convention:

MMM\_MSIL1C\_YYYYMMDDTHHMMSS\_Nxxyy\_ROOO\_Txxxxx\_<Product Discriminator>

where:

- MMM: is the mission ID (S2A/S2B)
- YYYYMMDDTHHMMSS: is the Datatake Sensing Time



- xxyy: identifies the current processing baseline
- OOO: is the relative orbit number
- Txxxx: is the tile ID
- <Product Discriminator>: this field guarantees the uniqueness of the Single Tile product name; its value is the Level-1C Single Tile product CREATION DATE in the format yyyyymmddThhmmss.

For instance:

S2A\_MSIL1C\_20150802T105414\_N0102\_R008\_T30RWQ\_20150803T124046.SAFE

#### 4.9.11.2 Complete Single Tile Download Option

As anticipated in the section 4.4, the *Complete Single Tile* download option allows to include as part of the Level-1C Single Tile User Product all the full data associated to every single Tile in terms of any kind of imagery and metadata (i.e. expertise).

The *Complete Single Tile* product features all the characteristics of the *Single Tile Product in which all product items* (all Spectral Bands, the TCI band, Expertise level of metadata) are included. The Complete Single Tile does not include auxiliary data and BWI.

In addition, the <Product Discriminator> field of the product root directory name is specialised to ensure a deterministic repeatable name across time for the same product.

Example of the product root directory name for product in Complete Single Tile format:

S2A\_MSIL1C\_20160914T074612\_N0204\_R135\_T36JTT\_20160914T081456.SAFE



**Sentinel-2 Products  
Specification Document**

REF : S2-PDGS-TAS-DI-PSD  
ISSUE : 14.5  
DATE : 14/03/2018  
PAGE : 453 / 510



#### 4.9.12 True Colour Image Naming Convention

This section defines the different naming conventions applicable to the TCI files when they are selected as any other spectral band (cf. band selection download option for Level-1C products defined in section 4.4). The name of the TCI files are harmonised with the name of the Level-1C tiles where the band suffix 'Bxx' is replaced with the literal string 'TCI'.

Example of the name of TCI files when downloaded as band in SAFE format:

S2A\_OPER\_MSI\_L1C\_TL\_MTI\_\_20160615T115939\_A005123\_T36RVT\_TCI.jp2

Example of the name of TCI files when downloaded as band in SAFE\_COMPACT format:

T30RWQ\_20150802T122135\_TCI.jp2

### 4.10 Level-2A User Product Specification

#### 4.10.1 Introduction

The Level-2A product contains: Bottom-Of-Atmosphere (BOA) reflectance orthoimage, Aerosol Optical Thickness (AOT) map, Water Vapour (WV) map, Scene Classification map and Quality Indicators data.

Level-2A products are resampled as Level-1C products with a constant GSD (Ground Sampling Distance) of 10 m, 20 m and 60 m according to the native resolution of the different spectral bands.

The geographic coverage of Level-2A products is the same as the Level-1C input products.

Note that one Level-2A product:

- refers always to one Datatake;
- refer to one or several Datastrip from the same Datatake;
- may cover the full Datatake or an extract of the Datatake.





**Sentinel-2 Products  
Specification Document**

REF : S2-PDGS-TAS-DI-PSD  
ISSUE : 14.5  
DATE : 14/03/2018  
PAGE : 455 / 510

In the case of an extract, the image data are provided to cover the selected extract.

Figure **93** gives an overview of the L2A Product Physical Format. Please refer to following sections of this document for more details.

The Level-2A user product output format will be SAFE\_COMPACT.



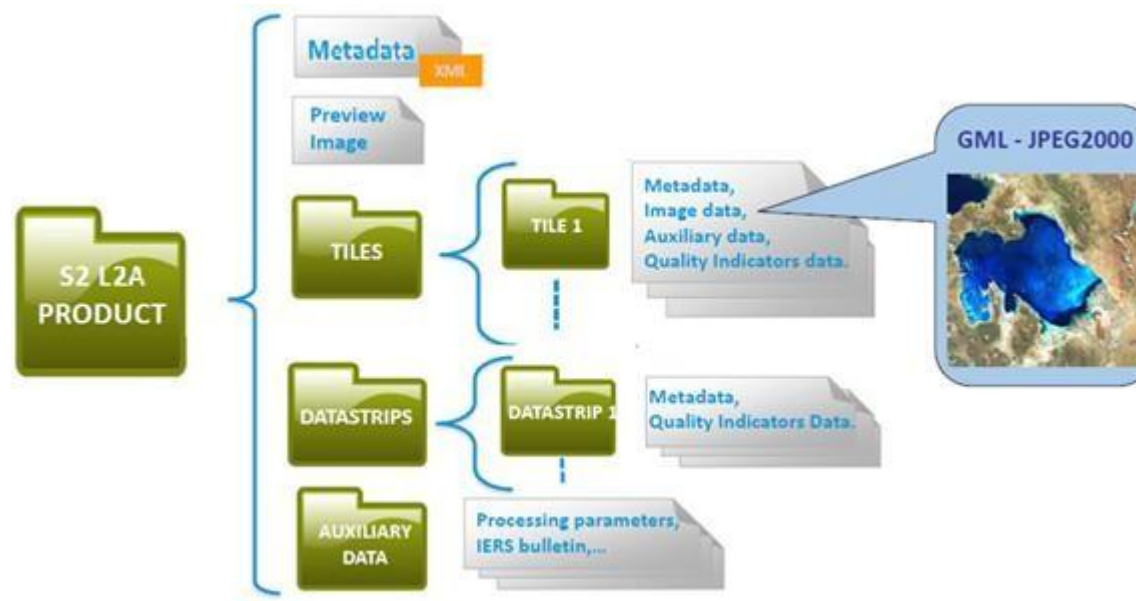

Figure 93: Level-2A Product Physical Format

Level-2A user product naming convention follows section 4.2.1



#### 4.10.2 Image Data

The Level-2 A image data is composed of BOA reflectance images, Aerosol Optical Thickness (AOT) maps, Water Vapour (WV) maps and Scene classification map (SCL).

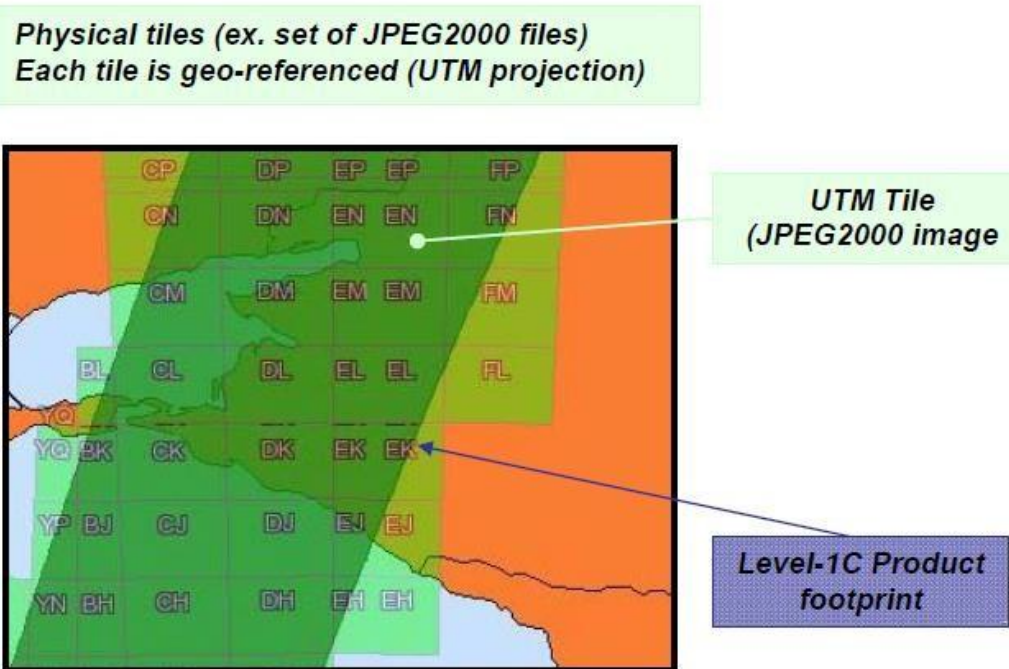

Figure 94: Example of Level-2A product tiled in several files

The Level-2A image data product uses the same tiling, encoding and filling structure as Level-1C.

The image data are provided as separated raster files see 3.13.2.2.

Each image file is compressed using the JPEG2000 algorithm. The parameters of the JPEG2000 compression are specified in the Annex G. The upper-left pixel corner coordinates of all bands shall have the same coordinates and shall be a multiple of 60m. For each file, the JPEG2000 header contains GML-JP2 information for ortho-image georeferencing. Each Tile is therefore geo-referenced.

#### 4.10.3 Ancillary data

The raw Satellite Ancillary Data are not embedded in the Level-2A User.

#### 4.10.4 Auxiliary Data

All Auxiliary Data used for Level-2A processing are referenced in the product metadata file.

The Level-2A auxiliary data (only GIPPs and IERS bulletin) are provided with the product if requested by the user (download option).

In addition, the Level-2A User Product embeds always at TILE level an elementary set of meteorological datasets extracted and resampled from ECMWF forecast output (cf. [ECMWF-FCAST]) and relevant to down-stream processing (e.g. atmospheric corrections).

The ECMWF auxiliary data embedded is processed **at Level-1C Tile level and** it is described in section **4.9.4**.

DEM, Snow Climatology Map used for Scene Classification, Water Bodies Map used for Scene Classification, Land Cover Map used for Scene Classification, Snow Condition Map Folder used for Scene Classification, libRadtran Look Up Tables used for Atmospheric Correction will be referenced in user product metadata but will **not provided** within the product.

#### 4.10.5 Quality Indicators

The *Product Level Quality Indicators* are provided at product level and referenced through the metadata file.

The *Tile Level Quality Indicators* are provided at Tile level in the standard structure of the metadata file.

The *Pixel Level Quality Indicators* are provided at Tile level through dedicated quality masks that provide quality information at pixel level. The Tile level metadata file (Standard structure) contains a pointer to the mask file.

Some QIs provided in Level-2A products are inherited from Level-1C QIs. QIs inherited from Level-1C products are provided as vector files; one for each type of mask and each tile. Each vector mask file consists of a set of polygons defined in ground geometry: (X, Y) in the projected frame.

#### 4.10.6 Metadata

The following table shows the groups of metadata provided inside a Level-2A User Product:

Level-2A User Product Metadata	
<b>Product Level Metadata</b>	All product level metadata, specific for the User level, are consolidated/computed because not present at Granule and Datastrip level.
<b>Granule Level Metadata (Brief/Standard/Expertise)</b>	All Brief/Standard/Expertise metadata (download option, cf. section 4.4) defined at Granule level are copied from the input Granules to the User Product.
<b>DATASTRIP Level Metadata (Brief/Standard/Expertise)</b>	All Brief/Standard/Expertise metadata (download option, cf. section 4.4) defined at Datastrip level are copied from the input Datastrips to the User Product;

Table 98: Level-2A Product Metadata

As mentioned in the section 2.10, the User Product metadata (all) are not provided with a *metadataLevel* attribute (Brief/Standard/Expertise) unlike what happens for all Granule and Datastrip metadata.

During the User Product assembling, this attribute is used to select by filtering, according to a download option, the set of metadata that must be included in the User Product.

For these filtered fields, the *metadataLevel* attribute is not written in the User Product's metadata.

Note that an User Product for an expert user (Expertise download option) will contain all level of metadata (Brief/Standard/Expertise). An User Product for a user with "Standard" or "Brief" permission will contain only Brief/Standard or Brief metadata.

In addition to the metadata in the table above, the User Product contains the *manifest.safe* metadata and the INSPIRE metadata.

The Level-2A Product Metadata are detailed in the section 4.10.74.9.7.

#### 4.10.7 User product Level-2A Structure

The *S2\_User\_Product\_Level-2A\_Structure.xsd* schema annexed to the document and shown in the following diagram, represents the structure of a S2 Level-2A User Product. This schema is



provided for information only as it is actually not expected to be used for the validation of a XML file.

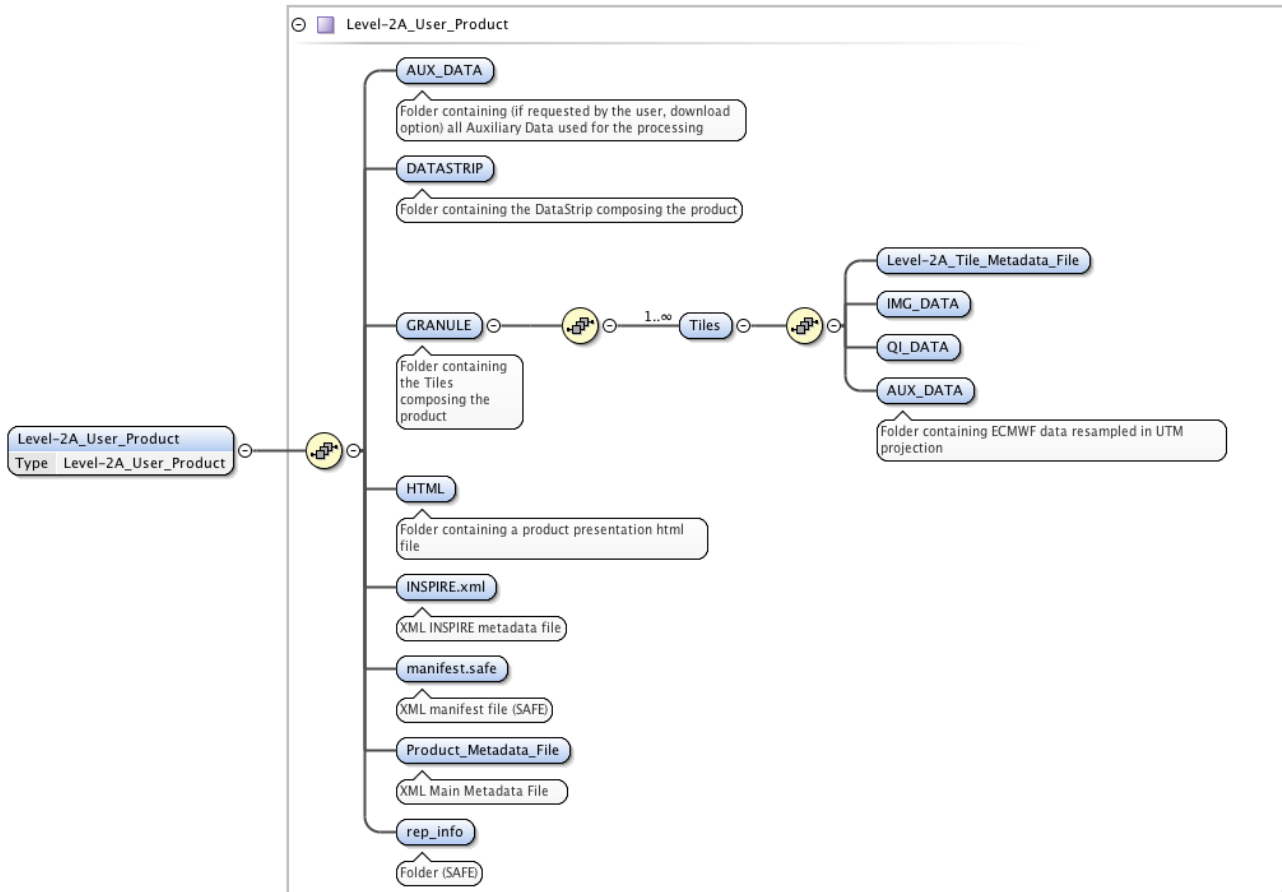
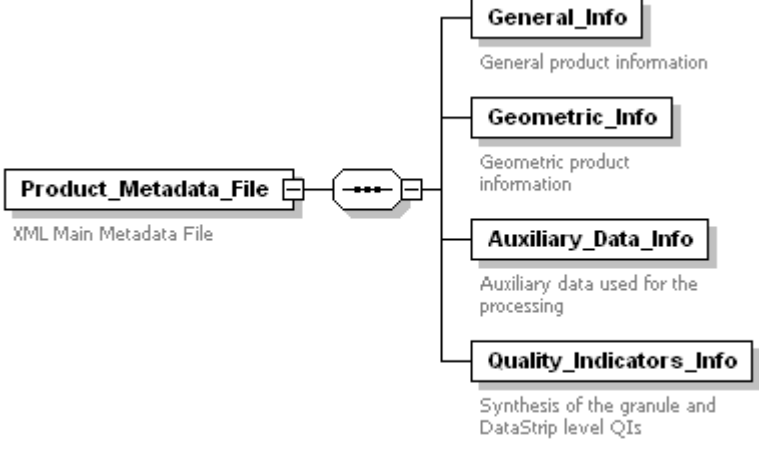

Figure 95: Level-2A user product structure

#### 4.10.7.1 Product\_Metadata\_File Schema

Product\_Metadata\_File is the XML metadata file provided inside the S2 Level-2A User Product. The XSD schema annexed to this document and used to validate it is *S2\_User\_Product\_Level-2A\_Metadata.xsd*.

A detailed description of the schema is given here but for specific details regarding each metadata (e.g. type, default value, fixed value, enumerations, occurrences, etc...) refers to the XSD file.

<p>diagram</p>	 <p>Generated by XMLSpy <a href="http://www.altova.com">www.altova.com</a></p>
<p>children</p>	<p><a href="#">General_Info</a> <a href="#">Geometric_Info</a> <a href="#">Auxiliary_Data_Info</a> <a href="#">Quality_Indicators_Info</a></p>
<p>Description</p>	<p>The Product_Metadata_File describes the product data items. It is presented to the user as a structured container of information. Product_Metadata_File is an XML file containing:</p> <ol style="list-style-type: none"> <li>1. <b>General_Info</b>: provides general product information.</li> <li>2. <b>Geometric_Info</b>: describing the geolocation over WGS84 of the contour of the product.</li> <li>3. <b>Auxiliary_Data_Info</b>: Links to the AUX_DATA items.</li> <li>4. <b>Quality_Indicators_Info</b>: Synthesis of the Granule and Datastrip level QIs.</li> </ol>

The following figures and tables give a complete description of the User Product metadata. All geometric product information are the same of L1C products.

General Info:

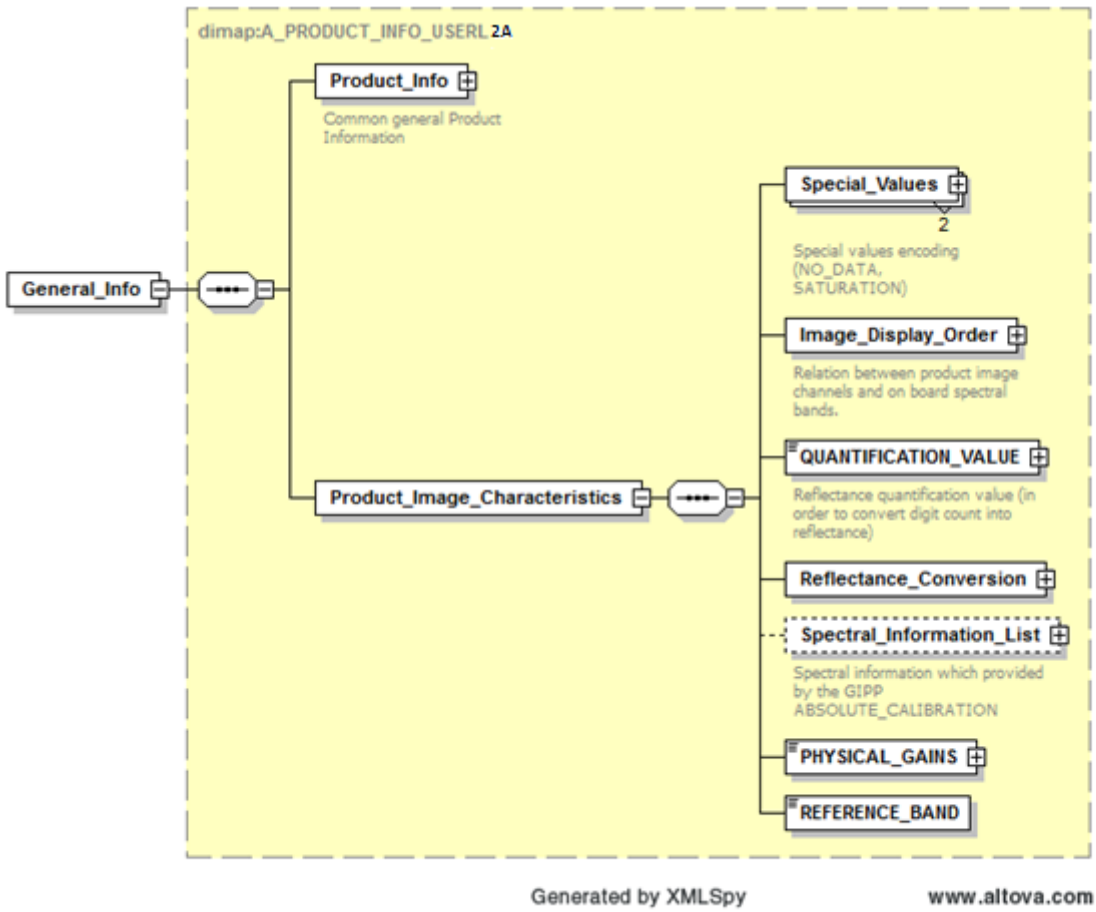

Figure 96: Level-2A\_Product\_Metadata\_File - General\_Info Diagram

General_Info	
Field Name	Description
Product_Info	This group of metadata is the same of L1C format
Product_Image_Characteristics/Special_Values/SPECIAL_VALUE_TEXT Product_Image_Characteristics/Special_Values/SPECIAL_VALUE_INDEX	This group of metadata is the same of L1C format
Product_Image_Characteristics/Image_Display_Order/RED_CHANNEL Product_Image_Characteristics/Image_Display_Order/GREEN_CHANNEL Product_Image_Characteristics/Image_Display_Order/BLUE_CHANNEL	Spectral bands (Relation between product image channels and on board spectral bands)
Product_Image_Characteristics/QUANTIFICATION_VALUE	Reflectances, Aerosol Optical Thickness and Water Vapor quantification values
Product_Image_Characteristics/Reflectance_Conversion/U	Correction to take into account the Sun-Earth distance variation (this correction is computed using the acquisition date)
Product_Image_Characteristics/ Reflectance_Conversion/Solar_Irradiance_List/SOLAR_IRRADIANCE	Reflectance parameters defined for each band
Product_Image_Characteristics/Spectral_Information_List/Spectral_Information/RESOLUTION Product_Image_Characteristics/Spectral_Information_List/Spectral_Information/Wavelength/MIN Product_Image_Characteristics/Spectral_Information_List/Spectral_Information/ Wavelength/MAX Product_Image_Characteristics/Spectral_Information_List/Spectral_Information/ Wavelength/CENTRAL Product_Image_Characteristics/Spectral_Information_List/Spectral_Information/Spectral_Response/STEP Product_Image_Characteristics/Spectral_Information_List/Spectral_	Spectral filter information
Product_Image_Characteristics/PHYSICAL_GAIN	Physical Gain for each band
Product_Image_Characteristics/REFERENCE_BAND	Used Reference Band

Table 99: Level-2A\_Product\_Metadata\_File - General\_Info Description



Auxiliary Data Info:

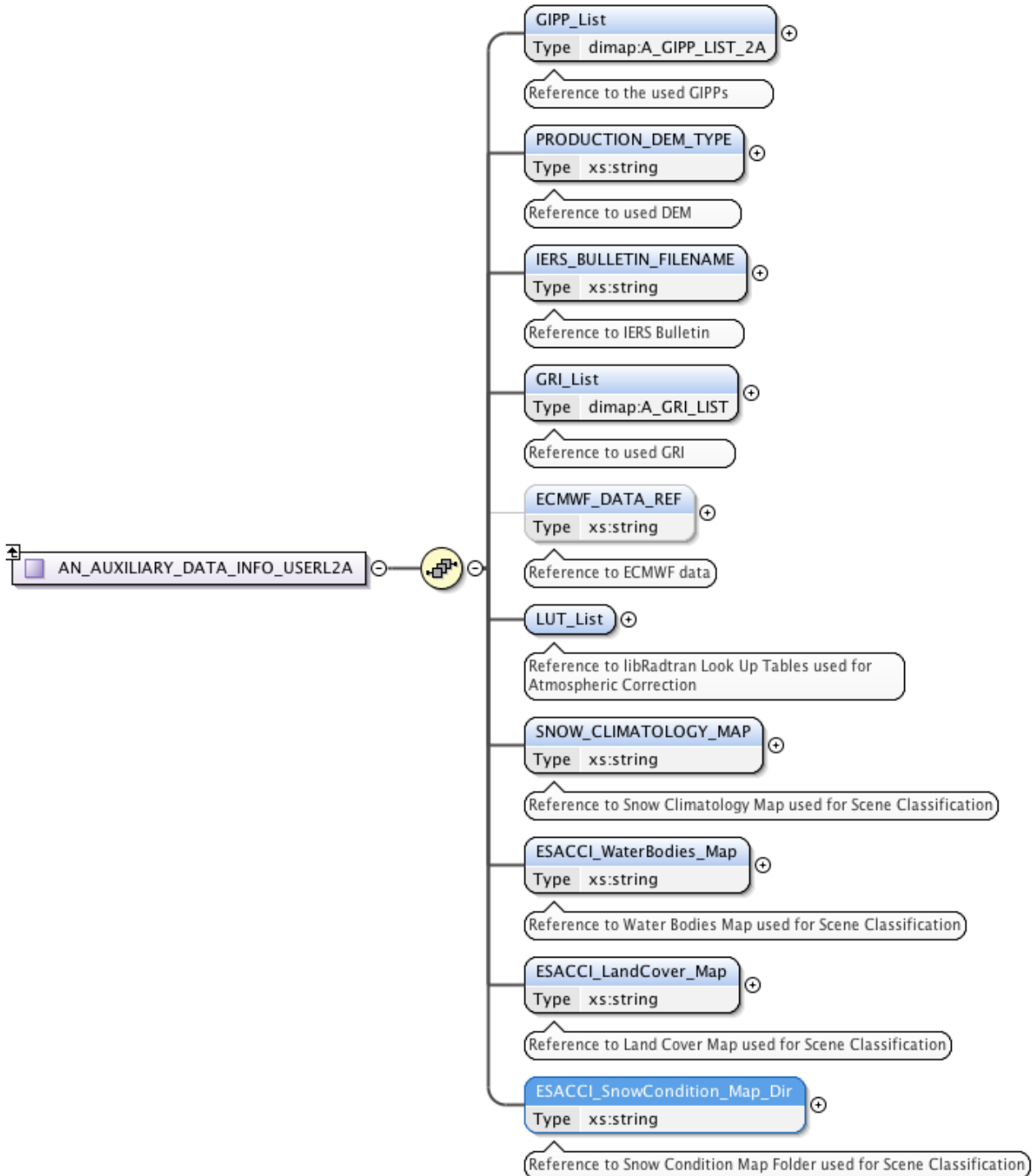

Figure 97: Level-2A Product\_Metadata\_File – Auxiliary\_Data\_Info Diagram

Auxiliary_Data_Info	
Field Name	Description
GIPP_FILENAME	Reference to the used GIPP files.
PRODUCTION_DEM_TYPE	Reference to the used DEM
IERS_BULLETIN_FILENAME	Reference to the used IERS Bulletin
GRI_FILENAME	Reference to the used GRI data
ECMWF_DATA_REF	Reference to the used ECMWF data
SNOW_CLIMATOLOGY_MAP	Reference to Snow Climatology Map used for Scene Classification
ESACCI_WaterBodies_Map	Reference to Water Bodies Map used for Scene Classification
ESACCI_LandCover_Map	R Reference to Land Cover Map used for Scene Classification
ESACCI_SnowCondition_Map_Dir	Reference to Snow Condition Map Folder used for Scene Classification
LUT_List	Reference to libRadtran Look Up Tables used for Atmospheric Correction

Table 100: Level-2A Product\_Metadata\_File - Auxiliary\_Info Description

Quality Indicators Info:

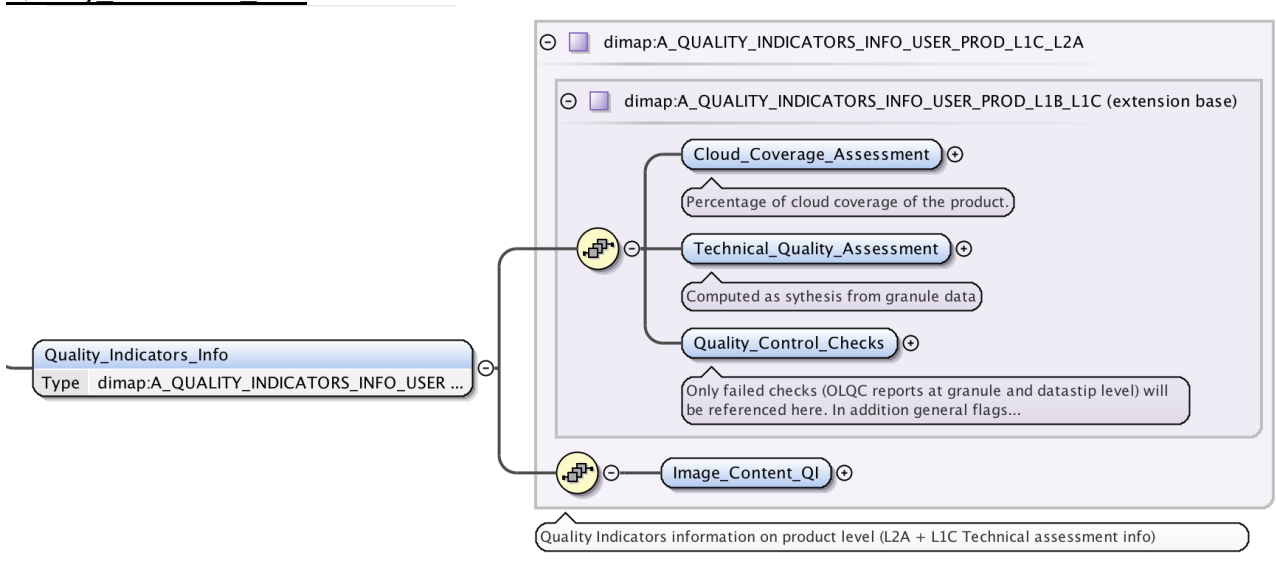

Figure 98: Level-2A Product\_Metadata\_File – Quality\_Indicators\_Info Diagram

Quality_Indicators_Info	
Field Name	Description
Cloud_Coverage_Assessment	Percentage of cloud coverage of the product.
Technical_Quality_Assessment	Computed as sythesis from granule data
Quality_Control_Checks	OLQC reports at tile and datastrip level
Image_Content_QI	Described in 3.13.2.1

Table 101: Level-2A Product\_Metadata\_File - Quality\_Indicators\_Info Description

#### 4.10.7.2 GRANULE

GRANULE folder contains a list of folders; each one containing a tile PDI composing the Level-2A user product. The content of tile PDI is described in 3.13.

The naming convention of the tile folders is:

L2A\_<Tile>\_<AbsoluteOrbit>\_<TileDiscriminator>

as described in the following table:

Field	Signification	Length (max)	Example Value
Tile	According to US-MGRS naming convention. (Inherited from Level-1C tile)	6	T32TNS
Absolute Orbit	Absolute Orbit Number A000000	7	A012360
Tile Discriminator	String discriminator to distinguish between partial tiles generated out of the same datatake	15	20171103T102724

Table 102: Level-2A Tile ID – Naming Convention

Example of S2 L2A tile name (Tile ID) is:

L2A\_T32TNS\_A012360\_20171103T102724

#### 4.10.7.3 DATASTRIP

DATASTRIP folder contains the list of folders each one corresponding to the Datastrips composing the Level-2A user product. The content of the Datastrip PDI is described in section 3.14.2

The name of each folder follows the syntax:

DS\_<Centre>\_<CreationDate>\_S<SensingStart>

The sub-fields are described in the following table:

Field	Signification	Length (max)	Example Value
Centre	Site Centre	4	MPS_
Creation Date	UTC Date/Time of creation date with seconds resolution : YYYYMMDDThhmmss	15	20171106T195236
Sensing Start	This time refers to the sensing start time of the Datastrip in UTC time. 14 digits, date and time, preceded by the character 'S' and separated by the character 'T'.	15	20171103T102724

Table 103: Level-2A Datastrip\_ID – Instance\_Id Naming Convention

Example of a S2 L2A Datastrip\_ID filename is:

DS\_MPS\_\_20171106T195236\_S20171103T102724

#### 4.10.7.4 AUX\_DATA

AUX\_DATA folder contains the auxiliary data files used for the processing. The naming convention used to identify each auxiliary file is the same of L1C SAFE COMPACT format. The GIPP files are physically grouped altogether into tar file named GIPP.tar as described in 4.9.10.

#### 4.10.8 Tiles Consolidation

For tile consolidation for Level-2A products refer to 4.9.8

#### 4.10.9 Single Tile User Product

The Level-2A Single Tile User Product is a download option applicable to the Level-2A User Product (*Single Tile Product Packaging* download option).

The Level-2A Single Tile User Product format is based on the Level-2A Used Product format defined in the section 4.10. For each Tile composing the Level-2A User Product a separate set of self-standing and fully consistent Level-2A Single Tile User-Products are generated covering one single Tile.



Figure 99: Level-2A User Product decomposition

The Level-2A Single Tile User Product physical format is the same defined in the section 4.10 and reported hereafter. In this case (*Single Tile Product Packaging* download option set to TRUE) the **GRANULE** folder contains one single Tile.

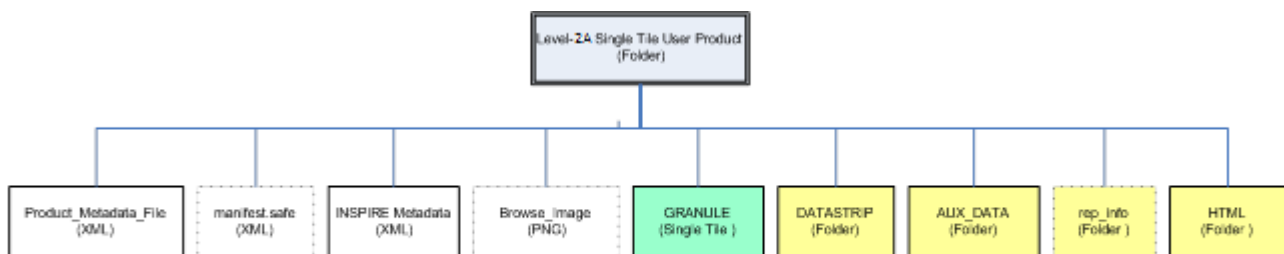

Figure 100: Level-2A Single Tile User Product Physical Format

The Level-2A Single Tile package output format will be SAFE\_COMPACT.

The Level-2A user product can be Complete Single Tile as described in 4.9.11.2

#### 4.10.9.1.1 Single Tile Naming Convention

Level-2A main product directory is identified according to the syntax derived from section 4.9.11. L1C and L2A products available from the Copernicus Open Hub are in complete single tile format: MMM\_DDDDDD\_<Instance\_ID>

Where: <Instance\_ID> =

[Datatake Sensing Time]\_Nxxyy\_ROOO\_Txxxxx\_[Product Discriminator]

Field	Signification	Length (max)	Example Value
MMM	Mission ID, e.g. S2A, S2B	3	S2A
n/a	Separator	1	_
DDDDDD	Semantic Descriptor, fixed string to identify Level-2A products	6	MSIL2A
n/a	Separator	1	_
Datatake Sensing Time	UTC Date/Time with second's resolution. Format: YYYYMMDDThhmmss	15	20171103T102201
n/a	Separator	1	_
Nxxyy	Production baseline	5	N0206
n/a	Separator	1	_
ROOO	Orbit Number (Relative orbit number) R000-R143	4	R065
n/a	Separator	1	_
Txxxxx	Tile number	6	T32TNS
n/a	Separator	1	_
Product Discriminator	Fixed string to distinguish different end user products associated to the same datatake. Format: YYYYMMDDThhmmss	15	20171106T195236
	<b>Total length for main product directory name without extension.</b>	<b>60</b>	

Table 104: Level-2A Single Tile Product name Nomenclature

Example of S2 L2A single tile product main directory:

S2A\_MSIL2A\_20171103T102201\_N0206\_R065\_T32TNS\_20171106T195236.SAFE

**ANNEX A: USER PRODUCT BASED ON DIMAP FORMAT**

A User Product based on DIMAP format has the same structure of the SAFE format one except for the product components specific of a SAFE product that are:

- *manifest.safe*
- *rep\_info*

For instance, the following diagram related to a L1A User Product, represents the structure of the product SAFE formatted when the *manifest.safe* and *rep\_info* are provided, differently it represents the structure of a product DIMAP formatted when *manifest.safe* and *rep\_info* are missing.

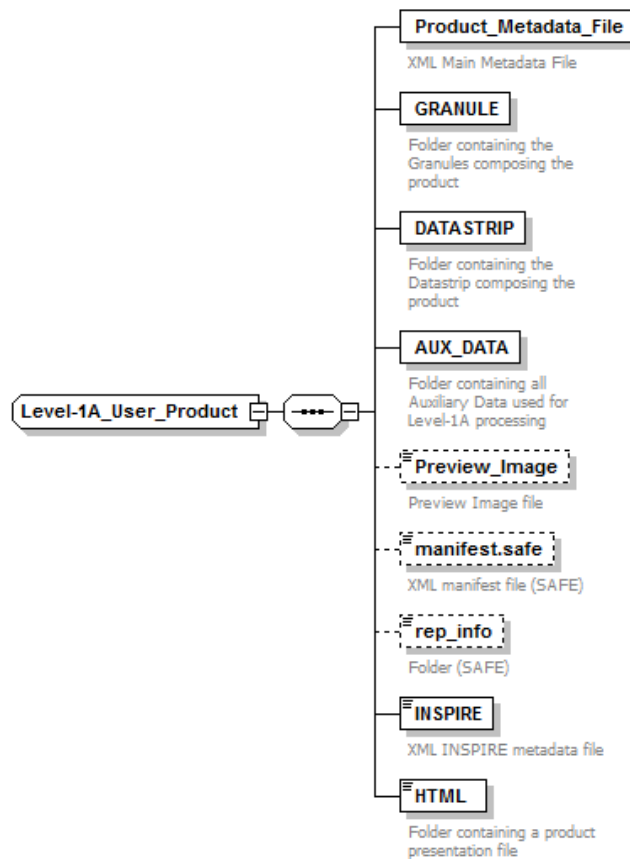

Generated by XMLSpy

www.altova.com

## ANNEX B: INSPIRE METADATA

**Infrastructure for Spatial Information in the European Community (INSPIRE)** is “an European Union initiative to establish an infrastructure for spatial information in Europe that helps to make spatial or geographical information more accessible and interoperable for a wide range of purposes supporting sustainable development”.

In Europe a major recent development has been the entering in force of the INSPIRE Directive in March 2007 (cf. [EC-INSPIRE-DIR]) establishing an Infrastructure for Spatial Information in Europe to support Community environmental policies, and policies or activities which may have an impact on the environment.

The Directive addresses [34 spatial data themes](#) needed for environmental applications

To ensure that the spatial data infrastructures of the Member States (27 Member States of the European Union) are compatible and usable in a Community and trans-boundary context, the Directive requires that common Implementing Rules (IR) are adopted in a number of specific areas (Metadata, Data Specifications, Network Services, Data and Service Sharing and Monitoring and Reporting).

Since, for the proper functioning of that infrastructure, it is necessary for a user to be able to find spatial data sets and services and to establish whether they may be used and for what purpose, Member States should provide descriptions in the form of metadata for those spatial data sets and services. Since such metadata should be compatible and usable in a Community and trans-boundary context, it is necessary to lay down rules concerning the metadata used to describe the spatial data sets and services corresponding to each theme.

In this context, the INSPIRE Metadata regulation [EC-INSPIRE-CR] dated 03/12/2008 defines a set of metadata necessary to allow identification of the information resource for which metadata is created, its classification and identification of its geographic location and temporal reference, quality and validity, conformity with implementing rules on the interoperability of spatial data sets and services, constraints related to access and use, and organization responsible for the resource. Metadata elements related to the metadata record itself are also necessary to monitor that the metadata created are kept up to date, and for identifying the organization responsible for the creation and maintenance of the metadata. This is the minimum set of metadata elements necessary to comply with Directive 2007/2/EC.

Moreover, instructions are necessary for the validation of metadata regarding to the conditions and expected multiplicity, the value domain of each metadata element is necessary to ensure interoperability of metadata in a multilingual context and that value domain should be able to take the form of free text, dates, codes derived from international standards, such as language codes, keywords derived from controlled lists or thesauri, or character strings.

INSPIRE Implementing Rules shall take account of relevant, existing international standards and user requirements. In the context of metadata for spatial data and spatial data services, the standards EN ISO 19115, EN ISO 19119 have been identified as important standards. XML representation of those metadata is ISO/TS 19139 encoded.

(cfr. <http://inspire.jrc.ec.europa.eu/index.cfm/pageid/101>)

For all details regarding INSPIRE DIRECTIVE Establishing an Infrastructure for Spatial Information and for INSPIRE REGULATION regarding Metadata generation, refers to the applicable

documents [EC-INSPIRE-DIR] and [EC-INSPIRE-CR] (cfr. <http://inspire.jrc.ec.europa.eu/index.cfm>).

As part of the GMES program, S2 PDGS support and use INSPIRE Metadata regulation (cfr. [EC-INSPIRE-CR] and [EC-INSPIRE-DIR]).

The Sentinel-2 datasets in their inherent quality of describing spatial data are fully entitled to comply with the directive and hence the INSPIRE Metadata directive applies in entirety to the Sentinel-2 product set.

In this context, the proposed approach is to generate an XML INSPIRE file 19115/19139 encoded, including the set of metadata characterizing the User Product, to be included in the product itself. A tailoring of the metadata filling the XML INSPIRE file has been done selecting the “Metadata elements” listed in the PART B of the applicable document [EC-INSPIRE-CR] and they are set out in the following tables. For each group of metadata, status (Dynamic (D), Static (S) or not applicable (-)), the multiplicity, the value domain and an example of the possible value are reported.

An example of XML INSPIRE metadata file has been generated and validated using the **Metadata Editor** tool provided in the INSPIRE Geoportal (<http://inspire-geoportal.ec.europa.eu/editor/>).

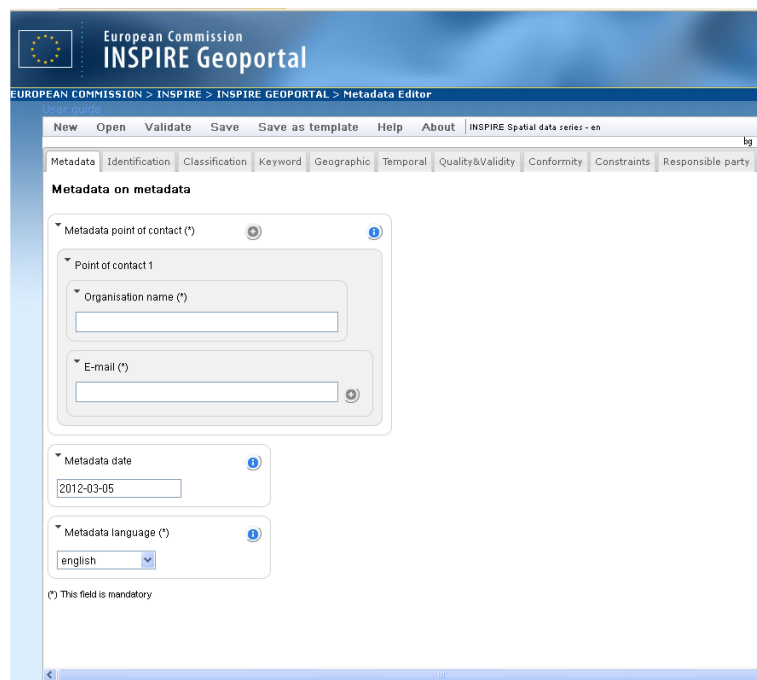

Figure 101: HMI of INSPIRE Metadata editor



**IDENTIFICATION**

Element name	INSPIRE Definition	(S)tatic (D)ynamic (-) N/A	Multiplicity	Value Domain	Value
Resource title	This is a characteristic, and often unique, name by which the resource is known.	D	1	free text	Product_Filename
Resource abstract	This is a brief narrative summary of the content of the resource.	D	1	free text	Product corresponding to a user-defined geographical selection
Resource type	This is the type of resource being described by the metadata.	S	1	From Part D.1 of [EC-INSPIRE-CR].	series
Resource locator	The resource locator defines the link(s) to the resource and/or the link to additional information about the resource.	D	01..*	character string (URL)	<a href="http://www.fao.org/geonetwork/srv/en/main.home">http://www.fao.org/geonetwork/srv/en/main.home</a>
Unique resource identifier	A value uniquely identifying the resource.	D	1..*	mandatory character string code, generally assigned by the data owner, and	“ <a href="http://www.isotc211.org/2005/resources/codeList.xml#CI_RoleCode">http://www.isotc211.org/2005/resources/codeList.xml#CI_RoleCode</a> ” “publisher”



**Sentinel-2 Products  
Specification Document**

REF : S2-PDGS-TAS-DI-PSD  
 ISSUE : 14.5  
 DATE : 14/03/2018  
 PAGE : 474 / 510

Element name	INSPIRE Definition	(S)tatic (D)ynamic (-) N/A	Multiplicity	Value Domain	Value
				a character string namespace uniquely identifying the context of the identifier code (for example, the data owner).	
Resource language	The language(s) used within the resource.	S	10..*	The value domain limited to the languages defined in ISO 639-2.	eng

**CLASSIFICATION OF SPATIAL DATA AND SERVICES**

Element name	INSPIRE Definition	(S)tatic (D)ynamic (-) N/A	Multiplicity	Value Domain	Value



Element name	INSPIRE Definition	(S)tatic (D)ynamic (-) N/A	Multiplicity	Value Domain	Value
Topic category	The topic category is a high-level classification scheme to assist in the grouping and topic-based search of available spatial data resources.	S	1..*	The value domain of this metadata element is defined in Part D.2 of [EC-INSPIRE-CR]. 2.10. Imagery / Base Maps / Earth Cover (imageryBaseMapsEarthCover) Base maps. This category applies to the following Directive 2007/2/EC spatial data themes: Annex II(3) Orthoimagery, Annex II(2) Land cover.	imageryBaseMapsEarthCover

#### KEYWORD

If a resource is a spatial data set, at least one keyword shall be provided from the general environmental multilingual thesaurus (GEMET) describing the relevant spatial data theme as defined in Annex I, II or III to Directive 2007/2/EC.

For each keyword, the following metadata elements shall be provided:

Element name	INSPIRE Definition	(S)tatic (D)ynamic (-) N/A	Multiplicity	Value Domain	Value
Keyword value	The keyword value is a commonly used word, formalised word or phrase used to describe the subject. While the topic	S	1..*	free text	Processing

Element name	INSPIRE Definition	(S)tatic (D)ynamic (-) N/A	Multiplicity	Value Domain	Value
Originating controlled vocabulary	<p>category is too coarse for detailed queries, keywords help narrowing a full text search and they allow for structured keyword search.</p> <p>If the keyword value originates from a controlled vocabulary (thesaurus, ontology), for example GEMET, the citation of the originating controlled vocabulary shall be provided.</p>	S	1..*	This citation shall include at least the title and a reference date (date of publication, date of last revision or of creation) of the originating controlled vocabulary.	Eionet GEMET Thesaurus Date of last revision 2011-09-12

### GEOGRAFIC LOCATION

The requirement for geographic location referred to in Article 11(2)(e) of Directive 2007/2/EC shall be expressed with the metadata element geographic bounding box.

Element name	INSPIRE Definition	(S)tatic (D)ynamic (-) N/A	Multiplicity	Value Domain	Value
Geographic bounding box	This is the extent of the resource in the geographic space, given as a bounding box.	D	1..*	The bounding box shall be expressed with westbound and eastbound longitudes, and southbound and northbound latitudes in	118.4 86.73 14.55 32.71



**Sentinel-2 Products  
Specification Document**

REF : S2-PDGS-TAS-DI-PSD  
 ISSUE : 14.5  
 DATE : 14/03/2018  
 PAGE : 477 / 510

Element name	INSPIRE Definition	(S)tatic (D)ynamic (-) N/A	Multiplicity	Value Domain	Value
				decimal degrees, with a precision of at least two decimals.	

**TEMPORAL REFERENCE**

Element name	INSPIRE Definition	(S)tatic (D)ynamic (-) N/A	Multiplicity	Value Domain	Value
Temporal extent	<p>The temporal extent defines the time period covered by the content of the resource. This time period may be expressed by:</p> <ul style="list-style-type: none"> <li>• an individual date,</li> <li>• an interval of dates expressed through the starting date and end date of the interval,</li> <li>• a mix of individual dates and intervals of dates.</li> </ul>	-S	01..*	<p>The date shall refer to a temporal reference system and shall be expressed in a form compatible with that system. The default reference system shall be the Gregorian calendar, with dates expressed in accordance with ISO 8601.</p>	2014-01-01
Date of publication	<p>This is the date of publication of the resource when available, or the date of entry into force. There may be more than one date of publication.</p>	S-	01..*	<p>The date shall refer to a temporal reference system and shall be expressed in a form compatible with that system. The default reference system shall be the Gregorian calendar,</p>	2030-01-01



Element name	INSPIRE Definition	(S)tatic (D)ynamic (-) N/A	Multiplicity	Value Domain	Value
				with dates expressed in accordance with ISO 8601.	
Date of last revision	This is the date of last revision of the resource, if the resource has been revised. There shall not be more than one date of last revision.	-	01..*	The date shall refer to a temporal reference system and shall be expressed in a form compatible with that system. The default reference system shall be the Gregorian calendar, with dates expressed in accordance with ISO 8601.	NA
Date of creation	This is the date of creation of the resource. There shall not be more than one date of creation.	D	01..1	The date shall refer to a temporal reference system and shall be expressed in a form compatible with that system. The default reference system shall be the Gregorian calendar, with dates expressed in accordance with ISO 8601.	2014-01-01

## QUALITY AND VALIDITY





**Sentinel-2 Products  
Specification Document**

REF : S2-PDGS-TAS-DI-PSD  
 ISSUE : 14.5  
 DATE : 14/03/2018  
 PAGE : 479 / 510

Element name	INSPIRE Definition	(S)tatic (D)ynamic (-) N/A	Multiplicity	Value Domain	Value
Lineage	This is a statement on process history and/or overall quality of the spatial data set. Where appropriate it may include a statement whether the data set has been validated or quality assured, whether it is the official version (if multiple versions exist), and whether it has legal validity.	D	1	free text	missing
Spatial resolution	Spatial resolution refers to the level of detail of the data set. It shall be expressed as a set of zero to many resolution distances (typically for gridded data and imagery-derived products) or equivalent scales (typically for maps or map-derived products).	D	01..*	A resolution distance shall be expressed as a numerical value associated with a unit of length.	20

**CONFORMITY**

Element name	INSPIRE Definition	(S)tatic (D)ynamic (-) N/A	Multiplicity	Value Domain	Value
Specification	This is a citation of the implementing rules adopted under Article 7(1) of Directive 2007/2/EC or other specification to which a particular resource conforms. A resource may conform to more than one implementing rules adopted under Article 7(1) of Directive	S	1..*	This citation shall include at least the title and a reference date (date of publication, date of last revision or of creation) of the implementing rules	Article 5a(1) to (4) and Article 7 of Decision 1999/468/EC



Element name	INSPIRE Definition	(S)tatic (D)ynamic (-) N/A	Multiplicity	Value Domain	Value
Degree	<p>2007/2/EC or other specification.</p> <p>This is the degree of conformity of the resource to the implementing rules adopted under Article 7(1) of Directive 2007/2/EC or other specification.</p>	S	1..*	<p>adopted under Article 7(1) of [EC-INSPIRE-DIR] or of the specification.</p> <p>From Part D.5 of [EC-INSPIRE-CR]. Degree of Conformity: <b>Conformant (conformant):</b> The resource is fully conformant with the cited specification. <b>Not Conformant (notConformant) :</b> The resource does not conform to the cited specification. <b>Not evaluated (notEvaluated):</b> Conformance has not been evaluated.</p>	conformant

**CONSTRAINT RELATED TO ACCESS AND USE**



Element name	INSPIRE Definition	(S)tatic (D)ynamic (-) N/A	Multiplicity	Value Domain	Value
Conditions applying to access and use	This metadata element defines the conditions for access and use of spatial data sets and services, and where applicable, corresponding fees as required by Article 5(2)(b) and Article 11(2)(f) of Directive 2007/2/EC.	S	1..*	free text  The element must have values. If no conditions apply to the access and use of the resource, "no conditions apply" shall be used. If conditions are unknown, "conditions unknown" shall be used. This element shall also provide information on any fees necessary to access and use the resource, if applicable, or refer to a uniform resource locator (URL) where information on fees is available.	no conditions apply
Limitations on public access	When Member States limit public access to spatial data sets and spatial data services under Article 13 of Directive 2007/2/EC, this metadata element shall provide information on the limitations and the reasons for them.  If there are no limitations on public access, this metadata element shall indicate that fact.	-	1..*	free text	NA



**Sentinel-2 Products  
Specification Document**

REF : S2-PDGS-TAS-DI-PSD  
 ISSUE : 14.5  
 DATE : 14/03/2018  
 PAGE : 482 / 510

**ORGANISATIONS RESPONSIBLE FOR THE ESTABLISHMENT, MANAGEMENT, MAINTENANCE AND DISTRIBUTION OF SPATIAL DATA SETS AND SERVICES**

Element name	INSPIRE Definition	(S)tatic (D)ynamic (-) N/A	Multiplicity	Value Domain	Value
Responsible party	This is the description of the organisation responsible for the establishment, management, maintenance and distribution of the resource.	S	1..*	This description shall include: - the name of the organisation as free text, - a contact e-mail address as a character string.  From Part D.6 of [EC-INSPIRE-CR].  <b>6. RESPONSIBLE PARTY ROLE</b>	respons_party respons_party@org.ext
Responsible party role	This is the role of the responsible organisation.	S	1..*	<b>6.1. Resource Provider (resourceProvider)</b> Party that supplies the resource.  <b>6.2. Custodian (custodian)</b> Party that accepts accountability and responsibility for the data and ensures appropriate care and maintenance of	user



Element name	INSPIRE Definition	(S)tatic (D)ynamic (-) N/A	Multiplicity	Value Domain	Value
				<p>the resource.</p> <p>6.3. Owner (owner) Party that owns the resource.</p> <p>6.4. User (user) Party who uses the resource.</p> <p>6.5. Distributor (distributor) Party who distributes the resource.</p> <p>6.6. Originator (originator) Party who created the resource</p> <p>6.7. Point of Contact (pointOfContact) Party who can be contacted for acquiring knowledge about or acquisition of the resource.</p> <p>6.8. Principal Investigator (principalInvestigator)</p>	

Element name	INSPIRE Definition	(S)tatic (D)ynamic (-) N/A	Multiplicity	Value Domain	Value
				<p>Key party responsible for gathering information and conducting research.</p> <p>6.9. Processor (processor) Party who has processed the data in a manner such that the resource has been modified.</p> <p>6.10. Publisher (publisher) Party who published the resource.</p> <p>6.11. Author (author) Party who authored the resource.</p>	

**METADATA ON METADATA**

Element name	INSPIRE Definition	(S)tatic (D)ynamic (-) N/A	Multiplicity	Value Domain	Value
Metadata point	This is the description of the organisation	S	1..*	This description shall	org_name



Element name	INSPIRE Definition	(S)tatic (D)ynamic (-) N/A	Multiplicity	Value Domain	Value
of contact	responsible for the creation and maintenance of the metadata.			include:  - the name of the organisation as free text,  - a contact e-mail address as a character string.	org_name@org.ext
Metadata date	The date which specifies when the metadata record was created or updated.	D	1	This date shall be expressed in conformity with ISO 8601.	2012-03-05
Metadata language	This is the language in which the metadata elements are expressed.	S	1	The value domain of this metadata element is limited to the official languages of the Community expressed in conformity with ISO 639-2.	eng

Setting the values listed above (in the column “Value”) in the **Metadata Editor** tool provided in the INSPIRE Geoportal (<http://inspire-geoportal.ec.europa.eu/editor/>), the following XML INSPIRE ISO 19115/19139 encoded is provided.

```
<?xml version="1.0" encoding="UTF-8"?><gmd:MD_Metadata xsi:schemaLocation="http://www.isotc211.org/2005/gmd
http://schemas.opengis.net/iso/19139/20060504/gmd/gmd.xsd" xmlns:gmd="http://www.isotc211.org/2005/gmd"
xmlns:gco="http://www.isotc211.org/2005/gco" xmlns:xsi="http://www.w3.org/2001/XMLSchema-instance"
xmlns:gml="http://www.opengis.net/gml" xmlns:xlink="http://www.w3.org/1999/xlink">
<gmd:fileIdentifier>
<gco:CharacterString>publisher</gco:CharacterString>
</gmd:fileIdentifier>
<gmd:language>
<gmd:LanguageCode codeList="http://www.loc.gov/standards/iso639-2/"
codeListValue="eng">eng</gmd:LanguageCode>
</gmd:language>
<gmd:characterSet>
<gmd:MD_CharacterSetCode codeSpace="ISOTC211/19115" codeListValue="MD_CharacterSetCode_utf8"
codeList="http://www.isotc211.org/2005/resources/Codelist/gmxCodeLists.xml#MD_CharacterSetCode">MD_CharacterS
etCode_utf8</gmd:MD_CharacterSetCode>
</gmd:characterSet>
<gmd:hierarchyLevel>
<gmd:MD_ScopeCode
codeList="http://standards.iso.org/ittf/PubliclyAvailableStandards/ISO_19139_Schemas/resources/Codelist/ML_gmxCod
elists.xml#MD_ScopeCode" codeListValue="dataset">dataset</gmd:MD_ScopeCode>
</gmd:hierarchyLevel>
<gmd:contact>
<gmd:CI_ResponsibleParty>
<gmd:organisationName>
<gco:CharacterString>org_name</gco:CharacterString>
</gmd:organisationName>
<gmd:contactInfo>
<gmd:CI_Contact>
<gmd:address>
<gmd:CI_Address>
<gmd:electronicMailAddress>
<gco:CharacterString>org_name@org.ext</gco:CharacterString>
</gmd:electronicMailAddress>
</gmd:CI_Address>
</gmd:address>
</gmd:CI_Contact>
</gmd:contactInfo>
<gmd:role>
<gmd:CI_RoleCode
codeList="http://standards.iso.org/ittf/PubliclyAvailableStandards/ISO_19139_Schemas/resources/Codelist/ML_gmxCod
elists.xml#CI_RoleCode" codeListValue="pointOfContact">pointOfContact</gmd:CI_RoleCode>
</gmd:role>
</gmd:CI_ResponsibleParty>
</gmd:contact>
<gmd:dateStamp>
<gco>Date>2012-03-05</gco>Date>
</gmd:dateStamp>
<gmd:metadataStandardName>
<gco:CharacterString>ISO19115</gco:CharacterString>
</gmd:metadataStandardName>
<gmd:metadataStandardVersion>
<gco:CharacterString>2003/Cor.1:2006</gco:CharacterString>
</gmd:metadataStandardVersion>
<gmd:identificationInfo>
<gmd:MD_DataIdentification>
<gmd:citation>
<gmd:CI_Citation>
<gmd:title>
<gco:CharacterString>Product_Filename</gco:CharacterString>
```

```
</gmd:title>
<gmd:date>
<gmd:CI_Date>
<gmd:date>
<gco:Date>2014-01-01</gco:Date>
</gmd:date>
<gmd:dateType>
<gmd:CI_DateTypeCode
codeList="http://standards.iso.org/ittf/PubliclyAvailableStandards/ISO_19139_Schemas/resources/Codelist/ML_gmxCod
elists.xml#CI_DateTypeCode" codeListValue="creation">creation</gmd:CI_DateTypeCode>
</gmd:dateType>
</gmd:CI_Date>
</gmd:date>
<gmd:identifier>
<gmd:RS_Identifier>
<gmd:code>
<gco:CharacterString>publisher</gco:CharacterString>
</gmd:code>
<gmd:codeSpace>
<gco:CharacterString>http://www.isotc211.org/2005/gmd</gco:CharacterString>
</gmd:codeSpace>
</gmd:RS_Identifier>
</gmd:identifier>
<gmd:identifier>
<gmd:RS_Identifier>
<gmd:code>
<gco:CharacterString>publisher</gco:CharacterString>
</gmd:code>
<gmd:codeSpace>
<gco:CharacterString>http://www.isotc211.org/2005/gmd</gco:CharacterString>
</gmd:codeSpace>
</gmd:RS_Identifier>
</gmd:identifier>
</gmd:CI_Citation>
</gmd:citation>
<gmd:abstract>
<gco:CharacterString>Product corresponding to a user-defined geographical selection</gco:CharacterString>
</gmd:abstract>
<gmd:pointOfContact>
<gmd:CI_ResponsibleParty>
<gmd:organisationName>
<gco:CharacterString>respons_party</gco:CharacterString>
</gmd:organisationName>
<gmd:contactInfo>
<gmd:CI_Contact>
<gmd:address>
<gmd:CI_Address>
<gmd:electronicMailAddress>
<gco:CharacterString>respons_party@org.ext</gco:CharacterString>
</gmd:electronicMailAddress>
</gmd:CI_Address>
</gmd:address>
</gmd:CI_Contact>
</gmd:contactInfo>
<gmd:role>
<gmd:CI_RoleCode
codeList="http://standards.iso.org/ittf/PubliclyAvailableStandards/ISO_19139_Schemas/resources/Codelist/ML_gmxCod
elists.xml#CI_RoleCode" codeListValue="user">user</gmd:CI_RoleCode>
</gmd:role>
</gmd:CI_ResponsibleParty>
```

```
</gmd:pointOfContact>
<gmd:descriptiveKeywords>
<gmd:MD_Keywords>
<gmd:keyword>
<gco:CharacterString>Orthoimagery</gco:CharacterString>
</gmd:keyword>
<gmd:keyword>
<gco:CharacterString>Land cover</gco:CharacterString>
</gmd:keyword>
<gmd:keyword>
<gco:CharacterString>Geographical names</gco:CharacterString>
</gmd:keyword>
<gmd:thesaurusName>
<gmd:CI_Citation>
<gmd:title>
<gco:CharacterString>GEMET - INSPIRE themes, version 1.0</gco:CharacterString>
</gmd:title>
<gmd:date>
<gmd:CI_Date>
<gmd:date>
<gco>Date>2011-09-12</gco>Date>
</gmd:date>
<gmd:dateType>
<gmd:CI_DateTypeCode
codeList="http://standards.iso.org/ittf/PubliclyAvailableStandards/ISO_19139_Schemas/resources/Codelist/ML_gmxCod
elists.xml#CI_DateTypeCode" codeListValue="revision">revision</gmd:CI_DateTypeCode>
</gmd:dateType>
</gmd:CI_Date>
</gmd:date>
</gmd:CI_Citation>
</gmd:thesaurusName>
</gmd:MD_Keywords>
</gmd:descriptiveKeywords>
<gmd:descriptiveKeywords>
<gmd:MD_Keywords>
<gmd:keyword>
<gco:CharacterString>data set series</gco:CharacterString>
</gmd:keyword>
<gmd:thesaurusName>
<gmd:CI_Citation>
<gmd:title>
<gco:CharacterString>INSPIRE - Glossary, version 3</gco:CharacterString>
</gmd:title>
<gmd:date>
<gmd:CI_Date>
<gmd:date>
<gco>Date>2010-01-12</gco>Date>
</gmd:date>
<gmd:dateType>
<gmd:CI_DateTypeCode
codeList="http://standards.iso.org/ittf/PubliclyAvailableStandards/ISO_19139_Schemas/resources/Codelist/ML_gmxCod
elists.xml#CI_DateTypeCode" codeListValue="publication">publication</gmd:CI_DateTypeCode>
</gmd:dateType>
</gmd:CI_Date>
</gmd:date>
</gmd:CI_Citation>
</gmd:thesaurusName>
</gmd:MD_Keywords>
</gmd:descriptiveKeywords>
<gmd:descriptiveKeywords>
```



```
<gmd:MD_Keywords>
<gmd:keyword>
<gco:CharacterString>processing</gco:CharacterString>
</gmd:keyword>
<gmd:thesaurusName>
<gmd:CI_Citation>
<gmd:title>
<gco:CharacterString>Eionet GEMET Thesaurus</gco:CharacterString>
</gmd:title>
<gmd:date>
<gmd:CI_Date>
<gmd:date>
<gco>Date>2011-09-12</gco>Date>
</gmd:date>
<gmd:dateType>
<gmd:CI_DateTypeCode
codeList="http://standards.iso.org/ittf/PubliclyAvailableStandards/ISO_19139_Schemas/resources/Codelist/ML_gmxCod
elists.xml#CI_DateTypeCode" codeListValue="revision">revision</gmd:CI_DateTypeCode>
</gmd:dateType>
</gmd:CI_Date>
</gmd:date>
</gmd:CI_Citation>
</gmd:thesaurusName>
</gmd:MD_Keywords>
</gmd:descriptiveKeywords>
<gmd:resourceConstraints>
<gmd:MD_Constraints>
<gmd:useLimitation>
<gco:CharacterString>no conditions apply</gco:CharacterString>
</gmd:useLimitation>
</gmd:MD_Constraints>
</gmd:resourceConstraints>
<gmd:spatialResolution>
<gmd:MD_Resolution>
<gmd:equivalentScale>
<gmd:MD_RepresentativeFraction>
<gmd:denominator>
<gco:Integer>20</gco:Integer>
</gmd:denominator>
</gmd:MD_RepresentativeFraction>
</gmd:equivalentScale>
</gmd:MD_Resolution>
</gmd:spatialResolution>
<gmd:language>
<gmd:LanguageCode codeList="http://www.loc.gov/standards/iso639-2/"
codeListValue="eng">eng</gmd:LanguageCode>
</gmd:language>
<gmd:topicCategory>
<gmd:MD_TopicCategoryCode>imageryBaseMapsEarthCover</gmd:MD_TopicCategoryCode>
</gmd:topicCategory>
<gmd:extent>
<gmd:EX_Extent>
<gmd:geographicElement>
<gmd:EX_GeographicBoundingBox>
<gmd:westBoundLongitude>
<gco:Decimal>-63.15</gco:Decimal>
</gmd:westBoundLongitude>
<gmd:eastBoundLongitude>
<gco:Decimal>-63.01</gco:Decimal>
</gmd:eastBoundLongitude>
```

```
<gmd:southBoundLatitude>
<gco:Decimal>18.05</gco:Decimal>
</gmd:southBoundLatitude>
<gmd:northBoundLatitude>
<gco:Decimal>18.12</gco:Decimal>
</gmd:northBoundLatitude>
</gmd:EX_GeographicBoundingBox>
</gmd:geographicElement>
<gmd:temporalElement>
<gmd:EX_TemporalExtent>
<gmd:extent>
<gml:TimePeriod gml:id="IDcd3b1c4f-b5f7-439a-afc4-3317a4cd89be" xsi:type="gml:TimePeriodType">
<gml:beginPosition>2014-01-01</gml:beginPosition>
<gml:endPosition>2030-01-01</gml:endPosition>
</gml:TimePeriod>
</gmd:extent>
</gmd:EX_TemporalExtent>
</gmd:temporalElement>
</gmd:EX_Extent>
</gmd:extent>
</gmd:MD_DataIdentification>
</gmd:identificationInfo>
<gmd:distributionInfo>
<gmd:MD_Distribution>
<gmd:distributionFormat>
<gmd:MD_Format>
<gmd:name>
<gco:CharacterString>unknown</gco:CharacterString>
</gmd:name>
<gmd:version>
<gco:CharacterString>unknown</gco:CharacterString>
</gmd:version>
</gmd:MD_Format>
</gmd:distributionFormat>
<gmd:transferOptions>
<gmd:MD_DigitalTransferOptions>
<gmd:onLine>
<gmd:CI_OnlineResource>
<gmd:linkage>
<gmd:URL>http://www.isotc211.org/2005/gmx</gmd:URL>
</gmd:linkage>
</gmd:CI_OnlineResource>
</gmd:onLine>
</gmd:MD_DigitalTransferOptions>
</gmd:transferOptions>
</gmd:MD_Distribution>
</gmd:distributionInfo>
<gmd:dataQualityInfo>
<gmd:DQ_DataQuality>
<gmd:scope>
<gmd:DQ_Scope>
<gmd:level>
<gmd:MD_ScopeCode codeListValue="dataset"
codeList="http://standards.iso.org/ittf/PubliclyAvailableStandards/ISO_19139_Schemas/resources/Codelist/ML_gmxCod
elists.xml#MD_ScopeCode">dataset</gmd:MD_ScopeCode>
</gmd:level>
</gmd:DQ_Scope>
</gmd:scope>
<gmd:report>
<gmd:DQ_DomainConsistency xsi:type="gmd:DQ_DomainConsistency_Type">
```

```
<gmd:result>
<gmd:DQ_ConformanceResult xsi:type="gmd:DQ_ConformanceResult_Type">
<gmd:specification>
<gmd:CI_Citation>
<gmd:title>
<gco:CharacterString>Article 5a(1) to (4) and Article 7 of Decision 1999/468/EC</gco:CharacterString>
</gmd:title>
<gmd:date>
<gmd:CI_Date>
<gmd:date>
<gco>Date>1999-01-01</gco>Date>
</gmd:date>
<gmd:dateType>
<gmd:CI_DateTypeCode
codeList="http://standards.iso.org/ittf/PubliclyAvailableStandards/ISO_19139_Schemas/resources/Codelist/ML_gmxCod
elists.xml#CI_DateTypeCode" codeListValue="creation">creation</gmd:CI_DateTypeCode>
</gmd:dateType>
</gmd:CI_Date>
</gmd:date>
</gmd:CI_Citation>
</gmd:specification>
<gmd:explanation>
<gco:CharacterString>See the referenced specification</gco:CharacterString>
</gmd:explanation>
<gmd:pass>
<gco:Boolean>true</gco:Boolean>
</gmd:pass>
</gmd:DQ_ConformanceResult>
</gmd:result>
</gmd:DQ_DomainConsistency>
</gmd:report>
<gmd:lineage>
<gmd:LI_Lineage>
<gmd:statement>
<gco:CharacterString>missing</gco:CharacterString>
</gmd:statement>
</gmd:LI_Lineage>
</gmd:lineage>
</gmd:DQ_DataQuality>
</gmd:dataQualityInfo>
</gmd:MD_Metadata>
```

**ANNEX C: OLQC REPORT XSD**

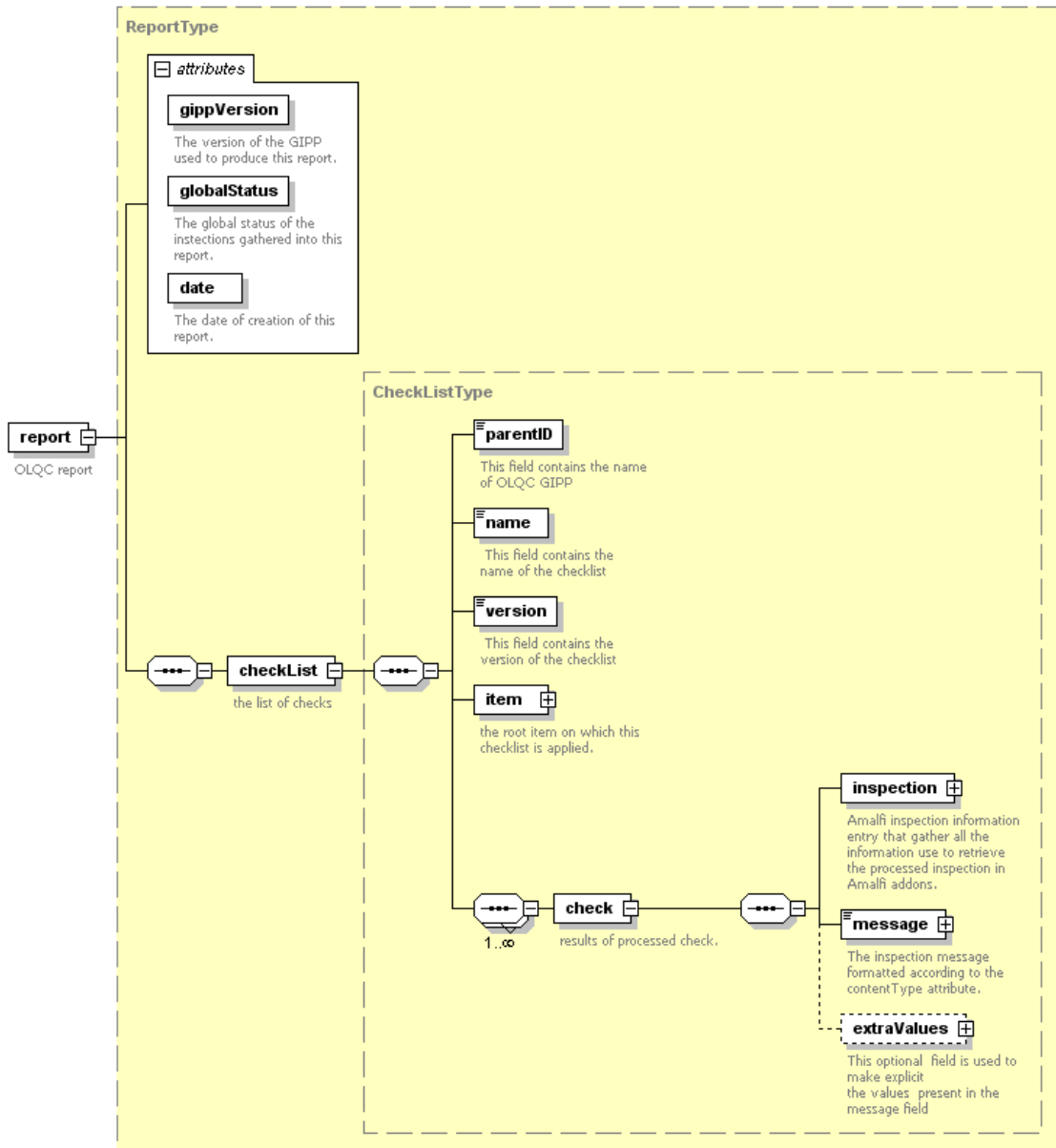

Generated by XMLSpy

www.altova.com

The naming convention used for the OLQC reports is:

PDI\_ID\_<checklistname>.report.xml

PDI\_ID is defined case by case in the chapter 3 for each Granule/Tile and Datastrip PDI and <checklistname> are defined in the following table.

For Granule/Tile PDI:

Checklist Name	L0c	L1A	L1B	L1C
SENSOR_QUALITY	Y	Y	Y	Y
GEOMETRIC_QUALITY	N	Y	Y	Y
GENERAL_QUALITY	N	Y	Y	Y
FORMAT_CORRECTNESS	Y	Y	Y	Y

For Datastrip PDI :

Checklist Name	L0c	L1A	L1B	L1C
SENSOR_QUALITY	Y	Y	Y	Y
GEOMETRIC_QUALITY	Y	Y	Y	Y
GENERAL_QUALITY	Y	Y	Y	Y
RADIOMETRIC_QUALITY	N	N	Y	Y
FORMAT_CORRECTNESS	Y	Y	Y	Y

Each report contains all checks related to the specific checklist name as defined in the Table 3-17 and Table 3-24.

The following example of OLQC XML report corresponds to:

inspected PDI = Level-0 Granule

S2A\_OPER\_MSI\_L0\_GR\_MTI\_20141104T134012\_S20141104T134012\_D01\_N01.12

Checklistname = SENSOR\_QUALITY

Checks = Corrupted\_ISP, Missing\_Lines, Sensing\_Time

GlobalStatus = PASSED (as all check status are PASSED)

```
<?xml version="1.0" encoding="UTF-8"?>
<!--Sample XML file generated by XMLSpy v2006 rel. 3 sp2 (http://www.altova.com)-->
<Earth_Explorer_File xmlns="http://gs2.esa.int/DATA_STRUCTURE/olqcReport"
xmlns:xsi="http://www.w3.org/2001/XMLSchema-instance"
xsi:schemaLocation="http://gs2.esa.int/DATA_STRUCTURE/olqcReport
\\bld16\auriemma\Desktop\olqcreport\OLQC_Report.xsd">
  <Earth_Explorer_Header>
    <Fixed_Header>
      <File_Name>String</File_Name>
      <File_Description>String</File_Description>
      <Notes>String</Notes>
      <Mission>S2_</Mission>
      <File_Class>String</File_Class>
      <File_Type>REP_OLQCPA</File_Type>
      <Validity_Period>
        <Validity_Start>UTC=0000-00-00T00:00:00</Validity_Start>
        <Validity_Stop>UTC=0000-00-00T00:00:00</Validity_Stop>
      </Validity_Period>
      <File_Version>2</File_Version>
      <Source>
        <System>String</System>
        <Creator>String</Creator>
        <Creator_Version>String</Creator_Version>
        <Creation_Date>UTC=0000-00-00T00:00:00</Creation_Date>
      </Source>
    </Fixed_Header>
  </Earth_Explorer_Header>
</Earth_Explorer_File>
```

```
</Fixed_Header>
<Variable_Header/>
</Earth_Explorer_Header>
<Data_Block type="xml">
  <report date="2001-12-17T09:30:47.0Z" gippVersion="01.00.01" globalStatus="PASSED">
    <checkList>
      <parentID>String</parentID>
      <name>SENSOR_QUALITY </name>
      <version>00.01</version>
      <item
url="D:/S2A_OPER_MSI_L0__GR_MTI__20141104T134012_S20141104T134012_D01_N01.12.tar"
className="SENTINEL 2 Level 0 granule "
name="S2A_OPER_MSI_L0__GR_MTI__20141104T134012_S20141104T134012_D01_N01.12"
class="http://pdgs.s2.esa.int/PSD"/>
        <check>
          <inspection
item="S2A_OPER_MSI_L0__GR_MTI__20141104T134012_S20141104T134012_D01_N01.12.tar" id="DimapPlan"
creation="2001-12-17T09:30:47.0Z" processingStatus="Done" status="PASSED" execution="2001-12-17T09:30:47.0Z"
duration="2.844" name="All Applicable Inspections Plan (Automatic)" priority="2"
itemURL="D:/S2A_OPER_MSI_L0__GR_MTI__20141104T134012_S20141104T134012_D01_N01.12.tar"/>
          <message contentType="Text">"plain/text">All inspection(s) passed
successfully</message>
        </check>
      <check>
        <inspection
item="S2A_OPER_MSI_L0__GR_MTI__20141104T134012_S20141104T134012_D01_N01.12.tar" id="Corrupted_ISP"
creation="2001-12-17T09:30:47.0Z" processingStatus="Done" status="PASSED" execution="2001-12-17T09:30:47.0Z"
duration="2.844" name="Corrupted_ISP I" priority="5"
itemURL="D:/S2A_OPER_MSI_L0__GR_MTI__20141104T134012_S20141104T134012_D01_N01.12.tar"/>
        <message contentType="Text">Check LOST ISP Percentage is less than
1,2%</message>
      </check>
    <check>
      <inspection
item="S2A_OPER_MSI_L0__GR_MTI__20141104T134012_S20141104T134012_D01_N01.12.tar" id="Sensing_Time "
creation="2001-12-17T09:30:47.0Z" processingStatus="Done" status="PASSED" execution="2001-12-17T09:30:47.0Z"
duration="2.844" name="Sensing_Time " priority="5"
itemURL="D:/S2A_OPER_MSI_L0__GR_MTI__20141104T134012_S20141104T134012_D01_N01.12.tar"/>
      <message contentType="Text">Check Sensing Time is correct</message>
    </check>
    <check>
      <inspection
item="S2A_OPER_MSI_L0__GR_MTI__20141104T134012_S20141104T134012_D01_N01.12.tar" id="Missing_Lines"
creation="2001-12-17T09:30:47.0Z" processingStatus="Done" status="PASSED" execution="2001-12-17T09:30:47.0Z"
duration="2.844" name="Missing_Lines " priority="5"
itemURL="D:/S2A_OPER_MSI_L0__GR_MTI__20141104T134012_S20141104T134012_D01_N01.12.tar"/>
      <message contentType="Text"> Missing Lines threshold exceeded. threshold(5) LostLineNumber(254)
DegradedLineNumber(365)</message>
      <extraValues>
        <value name="threshold">5</value>
        <value name="LostLineNumber">254</value>
        <value name="DegradedLineNumber">365</value>
      </extraValues>
    </check>
  </checkList>
</report>
</Data_Block>
</Earth_Explorer_File>
```

## ANNEX D: GROUND IMAGE PROCESSING PARAMETERS (GIPP)

The following table gives the list of GIPP files available for each kind of product level. The column "Remarks" indicates if the GIPP file is Satellite dependent and spectral band dependent. There are 34 GIPP file types and a total of 154 GIPP files:

- 23 GIPP Satellite dependent
- 1 GIPP Satellite independent
- 10x13 GIPP Spectral Band dependent

GIPP Description	Interface name / File Type	Volume	Remarks	L0	L1A	L1B	L1C	L2A
Pixel line of sight for each bands in the focal plane reference frame	[SATELLITE_ID]_[BAND_ID]_VIEWING_DIRECTIONS_FILE GIP_VIEDIR	1 MB for 10m band 500 KB for 20m bands 170 KB for 60m bands	Indexed by Satellite and by spectral bands	x	x	x	x	x
Platform model	[SATELLITE_ID]_SPACECRAFT_MODEL_FILE GIP_SPAMOD	50 KB	Indexed by Satellite	x	x	x	x	x
Earth model	EARTH_MODEL_FILE GIP_EARMOD	4 KB				x	x	x
Global geometrical parameters	[SATELLITE_ID]_GEOMETRICAL_PARAMETERS_FILE GIP_GEOPAR	8 KB	Indexed by Satellite			x	x	x
Description of the inter detectors overlapping area	[SATELLITE_ID]_INTER_DETECTOR_FILE GIP_INTDET	40 KB	Indexed by Satellite			x	x	x
Deconvolution filter for each deconvoluted band	[SATELLITE_ID]_[BAND_ID]_DECONVOLUTION_FILTER_FILE GIP_R2DEFI	100 KB for each band	Indexed by Satellite and by Spectral bands		x	x	x	x
Threshold file for deconvolution through wavelet packets	[SATELLITE_ID]_[BAND_ID]_DECONVOLUTION_THRESHOLD_FILE GIP_R2DECT	30 KB for each band	Indexed by Satellite and by Spectral bands		x	x	x	x

GIPP Description	Interface name / File Type	Volume	Remarks	L0	L1A	L1B	L1C	L2A
Wavelets filters	[SATELLITE_ID]_[BAND_ID] _WAVELET_FILTERS_FILE  GIP_R2WAFI	10 KB for each band	Indexed by Satellite and by Spectral bands		x	x	x	x
L2 Norm coefficients (denoising)	[SATELLITE_ID]_[BAND_ID] _L2_NORM_COEFFICIENT S_FILE  GIP_R2L2NC	30 KB for each band	Indexed by Satellite and by Spectral bands		x	x	x	x
Denoising thresholds (denoising)	[SATELLITE_ID]_[BAND_ID] _DENOISING_THRESHOLD S_FILE  GIP_R2DENT	30 KB for each band	Indexed by Satellite and by Spectral bands		x	x	x	x
Noise model (denoising)	[SATELLITE_ID]_NOISE_M ODEL_FILE  GIP_R2NOMO	4 KB	Indexed by Satellite		x	x	x	x
SWIR detectors arrangement parameters	[SATELLITE_ID]_SWIR_RE ARRANGEMENT_PARAME TERS_FILE  GIP_R2SWIR	20 KB	Indexed by Satellite		x	x	x	x
Radiometric equalization parameters on board (dark current, on-board inter pixel calibration)	[SATELLITE_ID]_[BAND_ID] _EQUALIZATION_ONBOAR D_PARAMETERS_FILE  GIP_R2EOB2	3 MB for 10m bands 1.5 MB for 20m bands 500 KB for 60m bands	Indexed by Satellite and by Spectral bands		x	x	x	x
Radiometric equalization parameters on ground (on- ground correction)	[SATELLITE_ID]_[BAND_ID] _EQUALIZATION_ONGROU ND_PARAMETERS_FILE  GIP_R2EQOG	3 MB for 10m bands 1.5 MB for 20m bands 500 KB for 60m bands	Indexed by Satellite and by Spectral bands		x	x	x	x
List of defective pixels	[SATELLITE_ID]_DEFECTIV E_PIXELS_FILE  GIP_R2DEPI	5 KB	Indexed by Satellite		x	x	x	x



GIPP Description	Interface name / File Type	Volume	Remarks	L0	L1A	L1B	L1C	L2A
List of blind pixels	[SATELLITE_ID]_BLIND_PIXELS_FILE  GIP_BLINDP	5 KB	Indexed by Satellite	x	x	x	x	x
Binning for 60m bands parameters (filters and undersampling)	[SATELLITE_ID]_BINNING_PARAMETERS_FILE  GIP_R2BINN	5 KB	Indexed by Satellite		x	x	x	x
Absolute calibration parameters	[SATELLITE_ID]_ABSOLUTE_CALIBRATION_PARAMETERS_FILE  GIP_R2ABCA	30 KB	Indexed by Satellite	x	x	x	x	x
Crosstalk correction	[SATELLITE_ID]_CROSSTALK_CORRECTIONS_FILE  GIP_R2CRCO	1 MB	Indexed by Satellite		x	x	x	x
AnaTm HK parameters file	[SATELLITE_ID]_ANA_TM_SAD_PARAMETERS_FILE  GIP_ATMSAD	40 KB	Indexed by Satellite	x	x	x	x	x
AnaTm image parameters file	[SATELLITE_ID]_ANA_TM_IMAGE_PARAMETERS_FILE  GIP_ATMIMA	40 KB	Indexed by Satellite	x	x	x	x	x
Datation parameters file	[SATELLITE_ID]_DATATION_PARAMETERS_FILE  GIP_DATATI	40 KB	Indexed by Satellite	x	x	x	x	x
LR Extraction parameters file	[SATELLITE_ID]_LR_EXTRACTION_PARAMETERS_FILE  GIP_LREXTR	40 KB	Indexed by Satellite	x	x	x	x	x
InitLoc Inv parameters file	[SATELLITE_ID]_INIT_LOC_INV_PARAMETERS_FILE  GIP_INVLOC	40 KB	Indexed by Satellite	x	x	x	x	x

GI PP Description	Interface name / File Type	Volume	Remarks	L0	L1A	L1B	L1C	L2A
CloudInv parameter file	[SATELLITE_ID]_CLOUD_INV_PARAMETERS_FILE GIP_CLOINV	20 KB	Indexed by Satellite	x	x	x	x	x
InitLoc production parameters file	[SATELLITE_ID]_INIT_LOC_PROD_PARAMETERS_FILE GIP_PRDLOC	20 KB	Indexed by Satellite		x	x	x	x
RadioS2 parameters file	[SATELLITE_ID]_RADIO_S2_PARAMETERS_FILE GIP_R2PARA	40 KB	Indexed by Satellite		x	x	x	x
GeoS2 parameters file (preProc)	[SATELLITE_ID]_GEO_S2_PARAMETERS_FILE GIP_G2PARA	25 KB	Indexed by Satellite			x	x	x
Geometric parameter to refine	[SATELLITE_ID]_PARAMETERS_TO_BE_REFINED_FILE GIP_G2PARE	5 KB	Indexed by Satellite			x	x	x
TilingS2 parameters file	[SATELLITE_ID]_TILING_S2_PARAMETERS_FILE GIP_TILPAR	10 KB	Indexed by Satellite				x	x
ResampleS2 parameters file (preProc)	[SATELLITE_ID]_RESAMPLE_S2_PARAMETERS_FILE GIP_RESPAR	10 KB	Indexed by Satellite				x	x
MaskS2 parameters file	[SATELLITE_ID]_MASK_S2_PARAMETERS_FILE GIP_MASPAR	10 KB	Indexed by Satellite		x	x	x	x
Calibration parameter for the scene classification algorithm	GIP_L2ACSC							x



## Sentinel-2 Products Specification Document

REF : S2-PDGS-TAS-DI-PSD  
ISSUE : 14.5  
DATE : 14/03/2018  
PAGE : 499 / 510

GIPP Description	Interface name / File Type	Volume	Remarks	L0	L1A	L1B	L1C	L2A
Calibration parameter for the atmospheric correction algorithm	GIP_L2ACAC							X
Processing baseline identifier of the generated L2a products	GIP_PROBA2							X



## **ANNEX E: MASK TYPES AND GROUPING STRATEGY FOR L1 PRODUCTS**

The following table shows the main and sub mask types. There are 8 main types of masks and for each main type, one GML file is defined.



**Sentinel-2 Products  
Specification Document**

REF : S2-PDGS-TAS-DI-PSD  
ISSUE : 14.5  
DATE : 14/03/2018  
PAGE : 501 / 510

Mask Type	Main Type	Sub Type	Comments	Processing Level
Technical quality masks	MSK_TECQUA	ANC_LOST	Ancillary lost data	L1A: one file per band and detector; L1B: one file per band and detector; L1C: one file per band and Tile;
		ANC_DEG	Ancillary degraded data	
		MSI_LOST	MSI lost data	
		MSI_DEG	MSI degraded data	
Radiometric quality masks	MSK_DEFECT	QT_DEFECTIVE_PIXELS	Defective pixels (matching defective columns)	L1A: one file per band and detector; L1B: one file per band and detector; L1C: one file per band and Tile;
Radiometric quality masks	MSK_SATURA	QT_SATURATED_PIXELS_L1A	Saturated pixels before on-ground radiometric processing	QT_SATURATED_PIXELS_L1A for L1A products : one file for each detector, each band;
		QT_SATURATED_PIXELS_L1B	Saturated pixels after on-ground radiometric processing	QT_SATURATED_PIXELS_L1A and/or QT_SATURATED_PIXELS_L1B for L1B products: one for each detector, each band;  QT_SATURATED_PIXELS_L1A and/or QT_SATURATED_PIXELS_L1B for L1C products: one for each tile, each band.
Radiometric quality masks	MSK_NODATA	QT_NODATA_PIXELS	No-data pixels	L1A: one file per band and detector; L1B: one file per band and detector; L1C: one file per band and Tile;
		QT_PARTIALLY_CORRECTED_PIXELS	Pixels partially corrected during cross-talk processing.	
Detector footprint masks	MSK_DETFOO	DETECTOR_FOOTPRINT	For each band and detector intersecting the Tile, a feature describes the intersected ground footprint	L1C: one file per band and Tile;
Coarse cloud masks	MSK_CLOLOW	CLOUD_INV	One file per band and detector	L1A: one file per band and detector; L1B: one file per band and detector;
Finer cloud masks	MSK_CLOUDS	OPAQUE	Opaque clouds	L1C: one file per Tile;
		CIRRUS	Cirrus clouds	



The proposed solution is to group the masks per type and per band.

Each mask GML file contains the mask feature related to the corresponding mask sub types given a specific band.

The following example shows the adopted grouping strategy. It refers to the MSK\_CLOUDS gml file and contains the mask features for the OPAQUE and CIRRUS sub types.

```
<?xml version="1.0" encoding="UTF-8" standalone="no" ?>
<eop:Mask gml:id=" S2A_OPER_MSK_CLOUDS_MTI__20141104T134012_A123456_T15SWC_B03_MSIL1C"
xmlns:gml="http://www.opengis.net/gml/3.2"
xmlns:eop="http://www.opengis.net/eop/2.0"
xmlns:xsi="http://www.w3.org/2001/XMLSchema-instance"
xsi:schemaLocation="http://www.opengis.net/eop/2.0 ../eop.xsd">
  <gml:name>Clouds mask from Tile S2A_OPER_MSI_L1C_TL_MTI__20141104T134012_A123456_T15SWC_N11.11</gml:name>
  <gml:boundedBy>
    <gml:Envelope srsName="urn:ogc:def:crs:EPSG:6.3:32614">
      <gml:lowerCorner>399960.000000 4300060.000000</gml:lowerCorner>
      <gml:upperCorner>509760.000000 4190260.000000</gml:upperCorner>
    </gml:Envelope>
  </gml:boundedBy>
  <eop:maskMembers>
    <eop:MaskFeature gml:id="opaque-0-B01-01-0000">
      <eop:maskType codeSpace="urn:gs2:S2PDGS:maskType">OPAQUE</eop:maskType>
      <eop:extentOf>
        <gml:Polygon gml:id="opaque-0-B01-01-0000_Polygon" srsName="urn:ogc:def:crs:EPSG:6.3:32614">
          <gml:exterior>
            <gml:LinearRing>
              <gml:posList>403950.000000 4230070.000000 404010.000000 .... 4230190.000000 403950.000000 4230070.000000</gml:posList>
            </gml:LinearRing>
          </gml:exterior>
          <gml:interior>
            <gml:LinearRing>
              <gml:posList>449130.000000 4299730.000000 449190.000000 ...4299610.000000 449130.000000 4299730.000000</gml:posList>
            </gml:LinearRing>
          </gml:interior>
          <gml:interior>
            <gml:LinearRing>
              <gml:posList>460530.000000 4299490.000000 460590.000000 ... 4299430.000000 460530.000000 4299490.000000</gml:posList>
            </gml:LinearRing>
          </gml:interior>
          .
          .
          .
          <gml:interior>
            <gml:LinearRing>
              <gml:posList>508470.000000 4205230.000000 508590.000000 ...4205170.000000 508470.000000 4205230.000000</gml:posList>
            </gml:LinearRing>
          </gml:interior>
        </gml:Polygon>
      </eop:extentOf>
    </eop:MaskFeature>
    <eop:MaskFeature gml:id="opaque-0-B01-01-0001">
      <eop:maskType codeSpace="urn:gs2:S2PDGS:maskType">OPAQUE</eop:maskType>
      <eop:extentOf>
        <gml:Polygon gml:id="opaque-0-B01-01-0001_Polygon" srsName="urn:ogc:def:crs:EPSG:6.3:32615">
          <gml:exterior>
            <gml:LinearRing>
              <gml:posList>382411.797918543 4290500 382411.797918543 4290500</gml:posList>
            </gml:LinearRing>
          </gml:exterior>
          <gml:Polygon>
          </eop:extentOf>
        </eop:MaskFeature>
    <eop:MaskFeature gml:id="cirrus-0-B01-01-0000">
      <eop:maskType codeSpace="urn:gs2:S2PDGS:maskType">CIRRUS</eop:maskType>
      <eop:extentOf>
```

```
<gml:Polygon gml:id="cirrus-0-B01-01-0000_Polygon" srsName="urn:ogc:def:crs:EPSG:6.3:32615">  
<gml:exterior>  
<gml:LinearRing>  
<gml:posList>382411.797918543 4290500 382411.797918543 4290500</gml:posList>  
</gml:LinearRing>  
</gml:exterior>  
</gml:Polygon>  
</eop:extentOf>  
</eop:MaskFeature>  
</eop:maskMembers>  
</eop:Mask>
```

*Remark: this example is not fully realistic, technical masks will not include "holes".*



**Sentinel-2 Products  
Specification Document**

REF : S2-PDGS-TAS-DI-PSD

ISSUE : 14.5

DATE : 14/03/2018

PAGE : 504 / 510





## ANNEX F: EXAMPLE OF METADATA FILE FOR A GRANULE AGGREGATED

```

<?xml version="1.0" encoding="UTF-8"?>
  <n1:Level-1A_Granule_ID xsi:schemaLocation="http://pdgs.s2.esa.int/PSD/S2_PDI_Level-1A_Granule_Metadata.xsd S2_PDI_Level-1A_Granule_Metadata.xsd" xmlns:n1="http://pdgs.s2.esa.int/PSD/S2_PDI_Level-1A_Granule_Metadata.xsd"
  xmlns:xsi="http://www.w3.org/2001/XMLSchema-instance">
    <n1:General_Info>
      <GRANULE_ID
metadataLevel="Brief">S2A_OPER_MSI_L1A_GR_MTI_20130621T120000_S20091211T165928_D07_N01.01</GRANULE_ID>
      <DETECTOR_ID metadataLevel="Brief">07</DETECTOR_ID>
      <DATASTRIP_ID
metadataLevel="Brief">S2A_OPER_MSI_L1A_DS_MTI_20130621T120000_S20091211T165928_N01.01</DATASTRIP_ID>
      <DOWNLINK_PRIORITY metadataLevel="Standard">NRT</DOWNLINK_PRIORITY>
      <SENSING_TIME metadataLevel="Standard">2009-12-11T16:58:51.592742566Z</SENSING_TIME>
      <Archiving_Info metadataLevel="Expertise">
        <ARCHIVING_CENTRE>MTI</ARCHIVING_CENTRE>
        <ARCHIVING_TIME>2013-02-19T10:15:44Z</ARCHIVING_TIME>
      </Archiving_Info>
    </n1:General_Info>
    <n1:Geometric_Info>
      <Granule_Footprint metadataLevel="Brief">
        <Granule_Footprint>
          <Footprint>
            <EXT_POS_LIST>37.781619442 -98.546300697 561.964 35.002917703 -
99.387519694 512.921 34.949015084 -99.117608113 444.079 37.726697926 -98.266969317 513.995 37.781619442 -98.546300697
561.964</EXT_POS_LIST>
          </Footprint>
        </Granule_Footprint>
        <RASTER_CS_TYPE>POINT</RASTER_CS_TYPE>
        <PIXEL_ORIGIN>1</PIXEL_ORIGIN>
      </Granule_Footprint>
      <Granule_Position metadataLevel="Standard">
        <POSITION>1</POSITION>
        <Geometric_Header>
          <GROUND_CENTER>36.448998142 -98.809781425 414.78</GROUND_CENTER>
          <QL_CENTER>4 5</QL_CENTER>
          <Incidence_Angles>
            <ZENITH_ANGLE unit="deg">2.37884</ZENITH_ANGLE>
            <AZIMUTH_ANGLE unit="deg">214.812</AZIMUTH_ANGLE>
          </Incidence_Angles>
          <Solar_Angles>
            <ZENITH_ANGLE unit="deg">62.9801</ZENITH_ANGLE>
            <AZIMUTH_ANGLE unit="deg">156.804</AZIMUTH_ANGLE>
          </Solar_Angles>
        </Geometric_Header>
      </Granule_Position>
      <Granule_Dimensions metadataLevel="Standard">
        <Size resolution="10">
          <NROWS>446026</NROWS>
          <NCOLS>2592</NCOLS>
        </Size>
        <Size resolution="20">
          <NROWS>223020</NROWS>
          <NCOLS>1296</NCOLS>
        </Size>
        <Size resolution="60">
          <NROWS>74354</NROWS>
          <NCOLS>1296</NCOLS>
        </Size>
      </Granule_Dimensions>
    </n1:Geometric_Info>
    <n1:Quality_Indicators_Info metadataLevel="Standard">
      <Image_Content_QI>
        <CLOUDY_PIXEL_PERCENTAGE>0.0304557</CLOUDY_PIXEL_PERCENTAGE>
        <DEGRADED_MSI_DATA_PERCENTAGE>0</DEGRADED_MSI_DATA_PERCENTAGE>
      </Image_Content_QI>
  </n1:Level-1A_Granule_ID>

```



```
<MASK_FILENAME bandId="6" type="MSK_SATURA"
detectorId="07">S2A_OPER_MSK_SATURA_MTI_0000000T000000_S20091211T165928_D07_B06_MSIL1A.gml</MASK_FILENAME>
<MASK_FILENAME bandId="6" type="MSK_TECQUA"
detectorId="07">S2A_OPER_MSK_TECQUA_MTI_0000000T000000_S20091211T165928_D07_B06_MSIL1A.gml</MASK_FILENAME>
<MASK_FILENAME bandId="7" type="MSK_CLOLOW"
detectorId="07">S2A_OPER_MSK_CLOLOW_MTI_0000000T000000_S20091211T165928_D07_B07_MSIL1A.gml</MASK_FILENAME>
<MASK_FILENAME bandId="7" type="MSK_DEFECT"
detectorId="07">S2A_OPER_MSK_DEFECT_MTI_0000000T000000_S20091211T165928_D07_B07_MSIL1A.gml</MASK_FILENAME>
<MASK_FILENAME bandId="7" type="MSK_NODATA"
detectorId="07">S2A_OPER_MSK_NODATA_MTI_0000000T000000_S20091211T165928_D07_B07_MSIL1A.gml</MASK_FILENAME>
<MASK_FILENAME bandId="7" type="MSK_SATURA"
detectorId="07">S2A_OPER_MSK_SATURA_MTI_0000000T000000_S20091211T165928_D07_B07_MSIL1A.gml</MASK_FILENAME>
<MASK_FILENAME bandId="7" type="MSK_TECQUA"
detectorId="07">S2A_OPER_MSK_TECQUA_MTI_0000000T000000_S20091211T165928_D07_B07_MSIL1A.gml</MASK_FILENAME>
<MASK_FILENAME bandId="8" type="MSK_CLOLOW"
detectorId="07">S2A_OPER_MSK_CLOLOW_MTI_0000000T000000_S20091211T165928_D07_B08_MSIL1A.gml</MASK_FILENAME>
<MASK_FILENAME bandId="8" type="MSK_DEFECT"
detectorId="07">S2A_OPER_MSK_DEFECT_MTI_0000000T000000_S20091211T165928_D07_B08_MSIL1A.gml</MASK_FILENAME>
<MASK_FILENAME bandId="8" type="MSK_NODATA"
detectorId="07">S2A_OPER_MSK_NODATA_MTI_0000000T000000_S20091211T165928_D07_B08_MSIL1A.gml</MASK_FILENAME>
<MASK_FILENAME bandId="8" type="MSK_SATURA"
detectorId="07">S2A_OPER_MSK_SATURA_MTI_0000000T000000_S20091211T165928_D07_B08_MSIL1A.gml</MASK_FILENAME>
<MASK_FILENAME bandId="8" type="MSK_TECQUA"
detectorId="07">S2A_OPER_MSK_TECQUA_MTI_0000000T000000_S20091211T165928_D07_B08_MSIL1A.gml</MASK_FILENAME>
<MASK_FILENAME bandId="9" type="MSK_CLOLOW"
detectorId="07">S2A_OPER_MSK_CLOLOW_MTI_0000000T000000_S20091211T165928_D07_B09_MSIL1A.gml</MASK_FILENAME>
<MASK_FILENAME bandId="9" type="MSK_DEFECT"
detectorId="07">S2A_OPER_MSK_DEFECT_MTI_0000000T000000_S20091211T165928_D07_B09_MSIL1A.gml</MASK_FILENAME>
<MASK_FILENAME bandId="9" type="MSK_NODATA"
detectorId="07">S2A_OPER_MSK_NODATA_MTI_0000000T000000_S20091211T165928_D07_B09_MSIL1A.gml</MASK_FILENAME>
<MASK_FILENAME bandId="9" type="MSK_SATURA"
detectorId="07">S2A_OPER_MSK_SATURA_MTI_0000000T000000_S20091211T165928_D07_B09_MSIL1A.gml</MASK_FILENAME>
<MASK_FILENAME bandId="9" type="MSK_TECQUA"
detectorId="07">S2A_OPER_MSK_TECQUA_MTI_0000000T000000_S20091211T165928_D07_B09_MSIL1A.gml</MASK_FILENAME>
<MASK_FILENAME bandId="10" type="MSK_CLOLOW"
detectorId="07">S2A_OPER_MSK_CLOLOW_MTI_0000000T000000_S20091211T165928_D07_B10_MSIL1A.gml</MASK_FILENAME>
<MASK_FILENAME bandId="10" type="MSK_DEFECT"
detectorId="07">S2A_OPER_MSK_DEFECT_MTI_0000000T000000_S20091211T165928_D07_B10_MSIL1A.gml</MASK_FILENAME>
<MASK_FILENAME bandId="10" type="MSK_NODATA"
detectorId="07">S2A_OPER_MSK_NODATA_MTI_0000000T000000_S20091211T165928_D07_B10_MSIL1A.gml</MASK_FILENAME>
<MASK_FILENAME bandId="10" type="MSK_SATURA"
detectorId="07">S2A_OPER_MSK_SATURA_MTI_0000000T000000_S20091211T165928_D07_B10_MSIL1A.gml</MASK_FILENAME>
<MASK_FILENAME bandId="10" type="MSK_TECQUA"
detectorId="07">S2A_OPER_MSK_TECQUA_MTI_0000000T000000_S20091211T165928_D07_B10_MSIL1A.gml</MASK_FILENAME>
<MASK_FILENAME bandId="11" type="MSK_CLOLOW"
detectorId="07">S2A_OPER_MSK_CLOLOW_MTI_0000000T000000_S20091211T165928_D07_B11_MSIL1A.gml</MASK_FILENAME>
<MASK_FILENAME bandId="11" type="MSK_DEFECT"
detectorId="07">S2A_OPER_MSK_DEFECT_MTI_0000000T000000_S20091211T165928_D07_B11_MSIL1A.gml</MASK_FILENAME>
<MASK_FILENAME bandId="11" type="MSK_NODATA"
detectorId="07">S2A_OPER_MSK_NODATA_MTI_0000000T000000_S20091211T165928_D07_B11_MSIL1A.gml</MASK_FILENAME>
<MASK_FILENAME bandId="11" type="MSK_SATURA"
detectorId="07">S2A_OPER_MSK_SATURA_MTI_0000000T000000_S20091211T165928_D07_B11_MSIL1A.gml</MASK_FILENAME>
<MASK_FILENAME bandId="11" type="MSK_TECQUA"
detectorId="07">S2A_OPER_MSK_TECQUA_MTI_0000000T000000_S20091211T165928_D07_B11_MSIL1A.gml</MASK_FILENAME>
<MASK_FILENAME bandId="12" type="MSK_CLOLOW"
detectorId="07">S2A_OPER_MSK_CLOLOW_MTI_0000000T000000_S20091211T165928_D07_B12_MSIL1A.gml</MASK_FILENAME>
<MASK_FILENAME bandId="12" type="MSK_DEFECT"
detectorId="07">S2A_OPER_MSK_DEFECT_MTI_0000000T000000_S20091211T165928_D07_B12_MSIL1A.gml</MASK_FILENAME>
<MASK_FILENAME bandId="12" type="MSK_NODATA"
detectorId="07">S2A_OPER_MSK_NODATA_MTI_0000000T000000_S20091211T165928_D07_B12_MSIL1A.gml</MASK_FILENAME>
<MASK_FILENAME bandId="12" type="MSK_SATURA"
detectorId="07">S2A_OPER_MSK_SATURA_MTI_0000000T000000_S20091211T165928_D07_B12_MSIL1A.gml</MASK_FILENAME>
<MASK_FILENAME bandId="12" type="MSK_TECQUA"
detectorId="07">S2A_OPER_MSK_TECQUA_MTI_0000000T000000_S20091211T165928_D07_B12_MSIL1A.gml</MASK_FILENAME>
</Pixel_Level_QI>
</n1:Quality_Indicators_Info>
</n1:Level-1A_Granule_ID>
```



**Sentinel-2 Products  
Specification Document**

REF : S2-PDGS-TAS-DI-PSD

ISSUE : 14.5

DATE : 14/03/2018

PAGE : 508 / 510



## ANNEX G: JPEG2000 COMPRESSION

The imagery files in the Level-1 User Product are compressed using JPEG2000 compression algorithms. JPEG2000 format is defined in [JP2STD].

JPEG2000 allows *lossless* or *lossy* compression and allows **optimizing** the products online delivery using the JPIP (JPEG2000 Interactive Protocol) streaming:

- LOSSLESS: Lossless compression, use reversible JPEG2000 compression.
- LOSSY: Lossy compression, use compression that ensures that JPEG2000 compression has a negligible effect on image quality.

Bands	Nb of Pixels (approx.)	Estimated size in GB with LOSSY Compression (eg. around 4,2 bits/pixels to be adjusted)	Estimated size in GB with LOSSLESS Compression (around 6bits/pixels in average)
4 Bands 10m	3364000000	1,645	2,350
6 Bands 20m	1261500000	0,617	0,881
3 Bands 60m	700833333	0,034	0,049
<b>TOTAL</b>		<b>2,296</b>	<b>3,280</b>

Figure 102 : Volume for image 290km x 290km, estimated with average JP2000 compression ratio)

The information is coded on 12 bits within the JPEG2000 format.

The JPEG2000 files are internally tiled (default tile size: 1024x1024).

The following configurable parameters are used to encode image in JPEG2000. Default values:

- Tile sizes : 1024x1024,
- Flush period : 1024 lines,
- Codeblock size : 64 (default value),
- Wavelet decomposition level : 5 (default value),
- Order : recommended order is RPCL (Resolution, Position, Colour component, Layer quality),
- Markers : ORGGen\_plt option is used to allow optimized decompression,
- SPrecision and Qstep are 2 parameters depending on image coding (8 or 12 bits),
- SPrecision = coding dynamic (8 or 12) and Qstep =  $1 / 2^{(coding\ dynamic)}$ ,
- Rate = 3.5 bits by colour plane.

Other parameters values are detailed in [JP2STD].

END OF DOCUMENT